







FILTRATION

EDITION 11/2003 - Cat 14.749

CITROËN



**FICHE QUALITE DES EDITIONS CATALOGUE PIECES AUTO
 AMENDMENT REQUEST QUALITY FORM PARTS CATALOGUE
 FICHA CALIDAD DE LAS EDICIONES CATALOGOS PIEZAS AUTO
 FICHA QUALIDADE EDIÇÕES CATÁLOGOS PEÇAS AUTO
 QUALITÄTS-DATENBLATT KATALOGAUSGABEN KFZ-TEILE
 SCHEDA QUALITÀ DELLE EDIZIONI CATALOGHI PEZZI AUTO
 KWALITEITSFICHE ONDERDELENCATALOGUS**

| EXPEDITEUR / SENDER | DESTINATAIRE / RECIPIENT |
|---|---|
| SOCIETE / COMPANY : | CITROËN / DSPC / MKSP |
| NOM / NAME : | NOM / NAME : Didier PAPILLAUD |
|  _____ |  01.58.79.73.95 |
|  _____ |  didier.papillaud@mpsa.com |
|  _____ | |

N° CAT 14. . . .

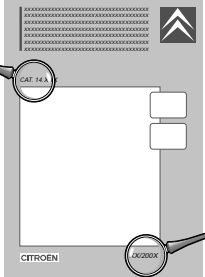

. . . / 200 .

ANOMALIE / CORRECTION / ANOMALIA / ANOMALIA / ANOMALIEN / ANOMALIA / FOUNT



SUGGESTION / SUGGESTION / SUGERENCIA / SUGESTÃO / VORSCHLÄGE / SUGGERIMENTO / SUGGESTIE



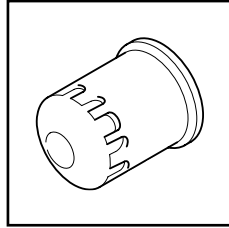

FILTRE A HUILE
OIL FILTER
FILTRO DE ACEITE
FILTRO DE OLEO
OELFILTER
FILTRO DELL'OLIO
OLIEFILTER

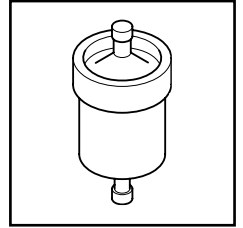

FILTRE ALIMENTATION
CARBURANT
PETROL FUEL FILTER
FILTRO COMBUSTIBLE
FILTRO DE ALIMENTAÇÃO
DO CARBURANTE
KRAFTSOFFILTER
FILTRO CARBURANTE
BENZINEFILTER

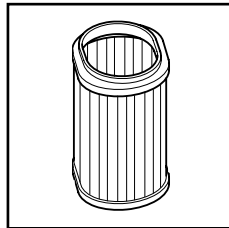

ELEMENT FILTRANT
FILTRE D'AIR
AIR FILTER
ELEMENTO FILTRANTE DE AIRE
ELEMENTO DO FILTRO DE AR
LUFTFILTEREINSATZ
CARTUCCIA ARIA
LUCHTFILTERLEMENT



CARTOUCHE DE FILTRE
DECANTEUR
DIESEL FUEL FILTER
ELEMENTO FILTRANTE DIESEL
CARTUCHO DE FILTRO
DIESELFILTER
CARTUCCIA GASOLIO
BRANDSTOFFFILTER (DIESEL)

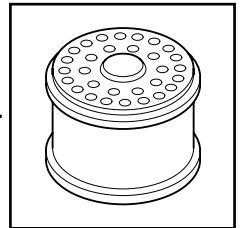

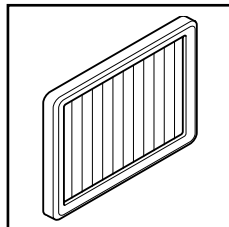

FILTRE D'HABITACLE
PARTICLE FILTER
FILTRO DE HABITACULO
FILTRO DE HABITÁCULO
INNENRAUMFILTER
FILTRO ABITACOLO
INTERIEURFILTER



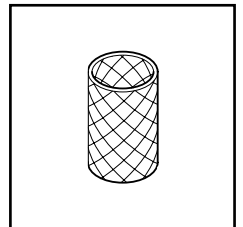

FILTRE GPL
LPG FILTER
FILTRO GPL
FILTRO GPL
FILTER GASANLAGE
FILTRO GPL
LPG-FILTER

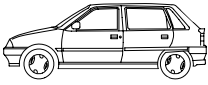
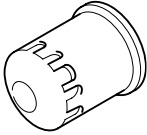
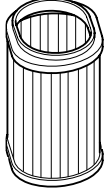

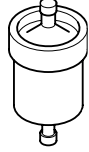
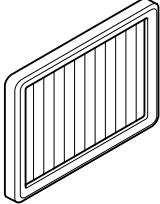
CITROËN AX

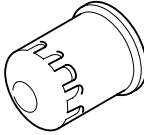
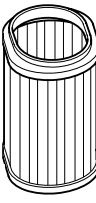

|  |  |  |  |  |  | | |
|---|---|---|---|---|---|---------|-----------------|
| Ess 1 L | 1109 N3 | 95 619 441 | | SRV 000 503 (Carbu) | | | |
| Ess 1,1 L Carbu | | | | | | | |
| Ess 1,1 L IE | 1109 J9 → 06/94 | 95 619 441 → 05/92 1444 A7 05/92 → | | | | | |
| Ess 1,3 L Sport | 1109 N3 1109 J9 | 95 619 726 NFP | | | | | |
| Ess 1,4 L | 1109 N3 1109 J9 → 06/94 | 95 619 441 → 04/91 1444 A7 05/91 → | | | | | 1567 79 (IE) |
| DI 1,4 L | 1109 N3 1109 J9 → 07/95 | 1444 F4 | | | | 1906 42 | |
| DI 1,5 L | | 1444 A5 | 1906 40 | | | | |

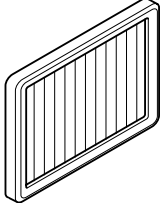
CITROËN C2

| | | | | | |
|---|---|---|--|---|---|
|  |  |  |  |  |  |
| (TU1JP - TU3JP) Ess 1,1 i L - 1,4 i L | 1109 R7 | 1444 X0 <input type="checkbox"/> 1444 X4 <input type="checkbox"/> | | 1567 A5 | 6447 NT 6447 NV <input type="checkbox"/> |
| (TU5JP4) Ess 1,6 i L 16 S | | 1444 X1 <input type="checkbox"/> 1444 X4 <input type="checkbox"/> | | | |
| (DV4TD) DI 1,4 L HDi | 1109 T3 | 1444 X3 <input type="checkbox"/> 1444 X7 <input type="checkbox"/> | 1901 73 | | |

- ✦ Avec charbon actif : With active carbon - Con carbon activo - Com carvão activo - Mit aktivkohle - Con carbone attivo - Met actieve koolstof
 Atmosphère normale : Normal atmosphere - Atmosfera normal - Atmosfera normal - Normale luftumgebung - Pressione atmosferica normal - Goed wegennet
 Atmosphère poussières : Dusty atmosphere - Atmosfera polvorienta - Atmosfera poluida - Staubige luftumgebung - Pressione atmosferica polverosa - slecht wegennet (stoffig)

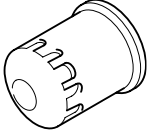
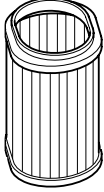
CITROËN C3

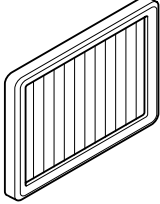

|  |  |  |  |  |  |
|---|---|---|---|---|---|
| (TU1JP - TU3JP) Ess 1,1 i L - 1,4 i L | 1109 R7 | 1444 X0 □ 1444 X4 □ □ | | | 6447 NT 6447 NV♦ □ |
| (ET3J4) Ess 1,4 i L 16 S | 1109 X4 | 1444 X0 | | 1567 A5 | |
| (TU5JP4) Ess 1,6 i L 16 S | 1109 R7 | 1444 X1 □ 1444 X4 □ □ | | | |
| (DV4TD) DI 1,4 L HDi | 1109 T3 | 1444 X3 □ 1444 X7 □ □ | 1901 68 RP 1901 73 | | |
| (DV4TED4) DI 1,4 L HDi 16 S | | 1444 X5 | 1901 67 | | |

♦ Avec charbon actif : With active carbon - Con carbon activo - Com carvão activo - Mit aktivkohle - Con carbone attivo - Met actieve koolstof

□ Atmosphère normale : Normal atmosphere - Atmosfera normal - Atmosfera normal - Normale luftumgebung - Pressione atmosferica normal - Goed wegennet

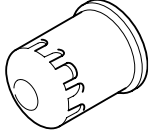
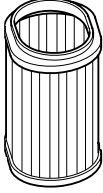

□ □ Atmosphère poussières : Dusty atmosphere - Atmosfera polvorienta - Atmosfera poluïda - Staubige luftumgebung - Pressione atmosferica polverosa - slecht wegennet (stoffig)

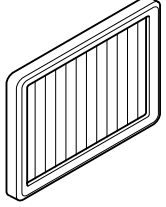
CITROËN C3 PLURIEL

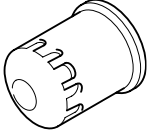
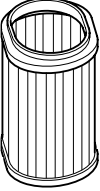
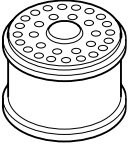
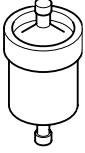
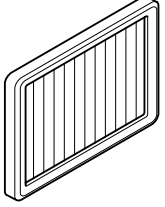

| | | | | | |
|---|---|---|--|---|---|
|  |  |  |  |  |  |
| (TU1JP - TU3JP) Ess 1,1 i L - 1,4 i L | 1109 R7 | 1444 X0 <input type="checkbox"/> 1444 X4 <input type="checkbox"/> | | 1567 85 | 6447 NT 6447 NV <input type="checkbox"/> |
| (TU5JP4) Ess 1,6 i L 16 S | | 1444 X1 <input type="checkbox"/> 1444 X4 <input type="checkbox"/> | | | |
| (DV4TD) DI 1,4 L HDi | 1109 T3 | 1444 X3 <input type="checkbox"/> 1444 X7 <input type="checkbox"/> | 1901 68 RP 1901 73 | | |

- ✦ Avec charbon actif : With active carbon - Con carbon activo - Com carvão activo - Mit aktivkohle - Con carbone attivo - Met actieve koolstof
 Atmosphère normale : Normal atmosphere - Atmosfera normal - Atmosfera normal - Normale luftumgebung - Pressione atmosferica normal - Goed wegennet
 Atmosphère poussières : Dusty atmosphere - Atmosfera polvorienta - Atmosfera poluida - Staubige luftumgebung - Pressione atmosferica polverosa - slecht wegennet (stoffig)

CITROËN SAXO

|  |  |  |  |  |  |
|---|---|---|---|--|---|
| (TU9M) Ess 1 L | 1109 N3 | 95 619 441 | | 1567 85 | 6441 G9 |
| (TU1M+) Ess 1,1 L | | 1444 A7 | | 1567 85 1635 P4 (GPL ) | |
| (TU1JP) Ess 1,1 L | 1109 R7 | 1444 E5 | | 1567 85 | |
| (TU3JP) Ess 1,4 L Sauf Dépol L4-K PRIM | 1109 N3 | | | | |
| (TU3JP) Ess 1,4 L Dépol L4-K PRIM | 1109 R7 | | | | |
| (TU5JP) Ess 1,6 L 90 CV Dépol L3 | 1109 N3 | 1444 A7 | | 1567 85 | |
| (TU5JP) Ess 1,6 L 100 CV Dépol L4 | 1109 R7 | 1444 V0 | | | |
| (TU5J4) Ess 1,6 L 16S | 1109 N3 | 1444 E8 | | | |
| (TUD5-TUD5B) DI 1,5 L | | 1444 A5 | 1906 42 1906 40 | | |

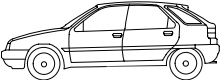
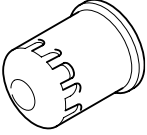
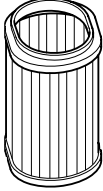
CITROËN ZX

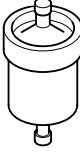
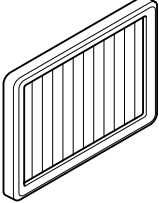
|  |  |  |  |  |  |
|---|---|---|--|---|---|
| (TU1-TU1M-TU1M+) Ess 1,1 L | 1109 N3 | 1444 A7 | | SRV 000 503 (Carbu) 1567 79 (IE) → 06/96 1567 85 (IE) 06/96 → | |
| (TU3M-TU3MC-TU3.2) Ess 1,4 L | | | | | |
| (TU3JP) Ess 1,4 L | 1109 N3 | 1444 E5 | | 1567 85 | |
| (TU5JP) Ess 1,6 L - 90 cv | | 1444 A7 | | 1567 79 | |
| (XU5M) Ess 1,6 L (IE Mono) | 1109 N3 1109 J9 | 95 658 435 | | 1567 79 | |
| (XU5JP) Ess 1,6 L IE | 1109 N3 1109 J9 → 07/94 | 96 144 871 | | 1567 79 → 06/96 | |
| (XU7JP) Ess 1,8 L | | | | 1567 85 06/96 → | |
| (XU7JP4) Ess 1,8 L 16S | 1109 N3 | 1444 F6 □ 1444 G2 □ □ | | 1567 85 | |
| (XU9) (XU9JA-XU9JAZ) Ess 1,9 L | 1109 N3 1109 J9 | 1444 F2 | | 1567 79 | |
| (XU10J2) Ess 2 L Sauf 16S | 1109 N3 1109 J9 → 07/94 | 96 144 871 | | 1567 79 → 06/96 1567 85 06/96 → | |
| (XU10J4) Ess 2 L | 1109 N3 1109 J9 → 07/94 | 1444 F2 | 1567 79 | | |



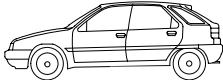
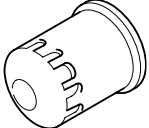
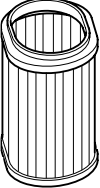
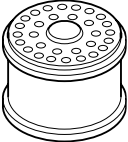
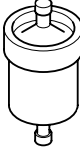
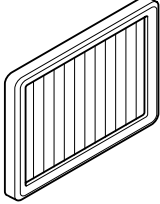

□ Atmosphère normale : Normal atmosphere - Atmosfera normal - Atmosfera normal - Normale luftumgebung - Pressione atmosferica normal - Goed wegennet

□ □ Atmosphère poussières : Dusty atmosphere - Atmosfera polvorienta - Atmosfera poluïda - Staubige luftumgebung - Pressione atmosferica polverosa - slecht wegennet (stoffig)

CITROËN ZX

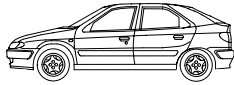
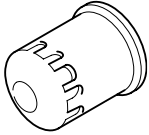
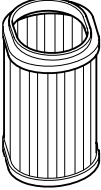

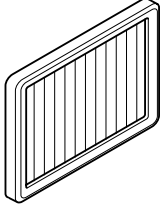

|  |  |  |  |  |  |
|---|---|---|---|---|---|
| (XU10J4R) Ess 2 L 16S | 1109 N3 1109 J9 → 07/94 | 1444 F2 | | 1567 79 | |
| (XU10J4RS) Ess 2 L 16S | 1109 N3 | 1444 E7 | | 1567 85 | |
| (TUD3) DI Atmo 1,4 L | 1109 N3 1109 J9 | 1444 F4 | 1906 42 | | |
| (TUD5) DI Atmo 1,5 L | 1109 N3 | 1444 F2 → 11/97 1444 H2 12/97 → | 1906 40 | | |
| (XUD7) DI Atmo 1,8 L | 1109 N3 1109 J9 → 05/95 | 1444 F5 | 1906 43 | | |
| (XUD9) DI Atmo 1,9 L | 1109 N3 | | | | |
| (XUD9TE) DI Turbo 1,9 L | 1109 J9 → 05/95 | 1444 F2 → 11/97 1444 H2 12/97 → | 1906 33 | | |

CITROËN XSARA → 08/2000

|  |  |  |  |  |  | |
|---|---|---|--|---|---|------------------|
| (TU3JP) Ess 1,4 L | 1109 N3 | 1444 E5 | | 1567 85 1635 P5  (GPL) | | |
| (TU5JP) Ess 1,6 L - 90 cv | | 1444 A7 | | | | |
| (XU7JB-XU7JP) Ess 1,8 L | | 96 144 871 | | | | |
| (XU7JP4) Ess 1,8 L 16S | | 1444 F6 □ 1444 G2 □□ | | | | |
| (XU10J4R) Ess 2 L 16S | | 1444 E7 | | 1567 85 | | |
| (XU10J4RS) Ess 2 L 16S | | | | | | |
| (TUD5) DI Atmo 1,5 L | | | | | | 1444 A5 |
| (XUD7) DI Atmo 1,8 L | | 1444 F5 | | 1906 43 | | 6447 FG + |
| (XUD9) DI Atmo 1,9 L | | 1444 F5 → 09/98 1444 G1 09/98 → | | 1906 33 | | |
| (DW8) DI Atmo 1,9 L | | <i>1109 R1</i> RP 1109 T1 1109 X2 | | 1444 H2 | | 1906 49 |
| (XUD9BSD) DI Atmo 1,9 L | 1109 N3 | 1444 F5 | 1906 43 1906 33 | | | |
| (XUD9TE) DI Turbo 1,9 L | | 1444 F2 → 11/97 1444 H2 11/97 → 02/2000 1444 G1 03/2000 → | | | | |
| (DW10-DW10TD) DI Turbo 2 L | <i>1109 R1</i> RP 1109 T1 1109 X2 | 1444 R6 □ 1444 J0 □□ | 1906 51 | | | |

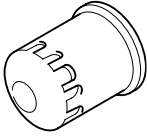
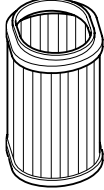

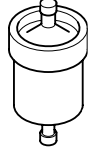
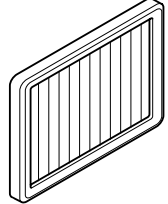
- + Réfri simple CAG : LHD simple aircon - Refri simple Conducción a izquierda - Refrigeração simples Condução à esquerda - Einfache Klimaanlage Linkslenkung - Climatizzatore manuale Guida a sinistra - Basis airco voor Linkse besturing
 ++ Sans réfri + Réfri régulée : Without aircon + Automatic aircon - Sin réfri + réfri regulado - Sem refrigeração + refrigeração regulada - Ohne Klimaanlage + regulierte Klimaanlage - Senza climatizzatore + climatizzatore automatico - Zonder airco + Temperatuurgeregelde airco
 □ Atmosphère normale : Normal atmosphere - Atmosfera normal - Atmosfera normal - Normale luftumgebung - Pressione atmosferica normal - Goed wegennet
 □□ Atmosphère poussières : Dusty atmosphere - Atmosfera polvorienta - Atmosfera poluída - Staubige luftumgebung - Pressione atmosferica polverosa - slecht wegennet (stoffig)

CITROËN XSARA 09/2000 →

| | | | | | | |
|---|---|---|---|--|---|---|
|  |  |  |  |  |  | |
| (TU3JP) Ess 1,4 L | 1109 R7 | 1444 J5 □ 1444 R1 □ □ | | 1567 85 1635 P4  (GPL) | | |
| (TU5JP4) Ess 1,6 L 16S | | 1444 E7 | | 1567 85 | | |
| (XU10J4RS) Ess 2 L 16S | | 1109 R1 RP 1109 T1 1109 X2 | | 1444 J3 □ 1444 R1 □ □ | | |
| (EW10J4) Ess 2 L 16S | | 1109 T3 | | 1444 X3 □ 1444 X7 □ □ | | 1901 73 |
| (DV4TD) DI 1,4 L HDi | | 1444 J3 □ 1444 R1 □ □ | 1906 49 | | 6447 Z4 x → 02/2001 | |
| (DW8B) DI Atmo 1,9 L | | 1109 R1 RP 1109 T1 1109 X2 | 1444 R3 □ 1444 R1 □ □ | | | 1906 51 deo 191723 (1) (Bosch) → 06/2001 sans FAP BVM → 06/2001 sans FAP BVA → 05/2002 1906 77 (Mahle) sans FAP BVM 06/2001 → sans FAP BVA 06/2002 → |
| (DW10TD- DW10ATED) DI Turbo 2 L | | | | | | |



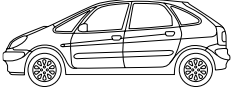
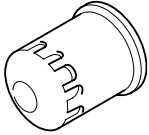
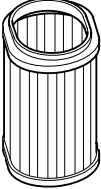

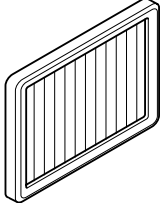
- **Atmosphère normale** : Normal atmosphere - Atmosfera normal - Atmosfera normal - Normale luftumgebung - Pressione atmosferica normal - Goed wegennet
- □ **Atmosphère poussières** : Dusty atmosphere - Atmosfera polvorienta - Atmosfera poluida - Staubige luftumgebung - Pressione atmosferica polverosa - slecht wegennet (stoffig)
- ✚ **Réfri simple CAG** : LHD simple aircon - Refri simple Conducción a izquierda - Refrigeração simples Condução à esquerda - Einfache Klimaanlage Linkslenkung - Climatizzatore manuale Guida a sinistra - Basis airco voor Linkse besturing
- ✕ **Sauf réfri CAG** : Except aircon + RHD automatic aircon - Salvo refri + refri regulado Conducción a derecha - Excepto refrigeração + refrigeração regulada Condução à direita - Ausser Klimaanlage + regulierte Klimaanlage Rechtslenkung - Salvo climatizzatore + climatizzatore automatico Guida a destra - Behalve airco + Temperatuurgeregelde airco voor Rechte besturing
- ✕ ✕ **Réfri régulée CAG** : LHD automatic aircon - Refri regulado Conducción a izquierda - Refrigeração regulada Condução à esquerda - Regulierte Klimaanlage Linkslenkung - Climatizzatore automatico Guida a sinistra - Temperatuurgeregelde airco voor Linkse besturing

CITROËN XSARA PICASSO

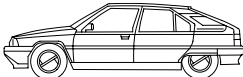
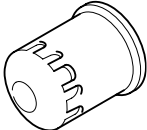
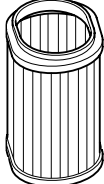

|  |  |  |  |  |  |
|---|---|---|---|---|---|
| (TU5JP) 90cv Ess 1,6 L | 1109 R1 RP 1109 T1 1109 X2 | 1444 J5 □ 1444 R1 □□ | | | 6447 FF 6447 LN* |
| (TU5JP) 100cv Ess 1,6 L | 1109 R7 | | | 1567 85 | |
| (EW7J4) Ess 1,8 L 16S | 1109 R1 RP 1109 T1 1109 X2 | 1444 J3 | | | |
| (EW10J4) Ess 1,8 L 16S | | 1444 R3 □ 1444 R1 □□ | | | |
| (DW10TD) DI Turbo 2 L | | 1444 R3 □ 1444 R1 □□ | 1906 51 deo 1917 23 → 06/2001 (Bosch) 1906 77 06/2001 → (Mahle) | | |

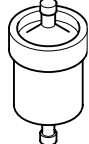
✦ Avec charbon actif : With active carbon - Con carbon activo - Com carvão activo - Mit aktivkohle - Con carbone attivo - Met actieve koolstof
 □ Atmosphère normale : Normal atmosphere - Atmosfera normal - Atmosfera normal - Normale luftumgebung - Pressione atmosferica normal - Goed wegennet
 □□ Atmosphère poussières : Dusty atmosphere - Atmosfera polvorienta - Atmosfera poluida - Staubige luftumgebung - Pressione atmosferica polverosa - slecht wegennet (stoffig)

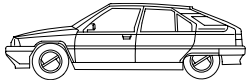
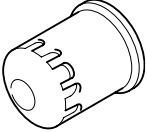
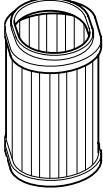

CITROËN BX

|  |  |  |  |  |  | | |
|--|---|---|---|---|---|--------------------------------|--|
| <p>Ess 1,124 L → 05/88</p> <p>Ess 1,360 L → 05/88</p> | <p>95 638 829</p> | <p>79 01 144 551 (Miofiltre)</p> | | | <p>9979 10</p> | | |
| <p>Ess 1,124 L 05/88 →</p> | | <p>94 01 445 798 (Mousse)</p> | | | | | |
| <p>Ess 1,360 L (Carbu) +(IE mono XT) 05/88 → 09/91</p> <p>Ess 1,360 L (IE mono sauf XT) 10/91 →</p> | <p>1109 N3</p> | <p>95 619 441</p> | | <p>SRV 000 503 (Carbu) (IE mono) → 02/92 (CH) (S) (A)</p> | | | |
| <p>Ess 1,360 L (Carbu-Carter fonte) 10/91 →</p> | | <p>1109 J9</p> | <p>1444 A7</p> | | | | |
| <p>Ess 1,580 L (Carbu) → 03/88</p> <p>Ess 15 RE, 15 TGE</p> <p>Ess 1,905 L (Carbu) sauf 4x4 → 05/89</p> | | | <p>95 605 128</p> | | | <p>1567 79 (IE)</p> | |
| <p>Ess 1,580 L (Carbu) 03/88 →</p> <p>Ess 1,580 L (IE Mono) (IE)</p> | | <p>1444 F4</p> | | | | | |

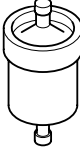
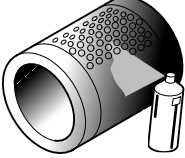
CITROËN BX

|  |  |  |  |  |  |
|---|---|---|--|---|---|
| <p>Ess 1,905 L (Carbu) 4x4 → 05/89</p> <p>Ess 1,905 L (Carbu) TT</p> <p>Ess 1,905 L (IE mono)</p> <p>Ess 1,905 L (IE)</p> <p>Ess GTI 16S</p> | <p>1109 N3</p> <p>1109 J9</p> | <p>1444 F4</p> | | <p>SRV 000 503 (Carbu) (IE mono) → 02/92 (CH) (S) (A)</p> <p>1567 79 (IE)</p> | |
| <p>DI Atmo 1,769 L</p> | <p>1109 N3</p> <p>1109 J9</p> | <p>95 605 128</p> | <p>95 608 910 (Purflux) 94 01 906 148 (Roto Diesel)</p> | | |
| <p>DI Atmo 1,905 L → 03/87</p> | | | <p>1906 43</p> | | |
| <p>DI Atmo 1,905 L 04/87 →</p> | | <p>1444 F4 95 605 128 (CH) (S)</p> | <p>1906 33</p> | | |
| <p>DI Turbo 1,769 L</p> | | <p>1444 F4</p> | <p>95 608 910 (Purflux) 94 01 906 148 (Roto Diesel)</p> | | |

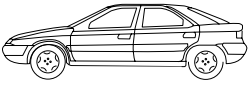
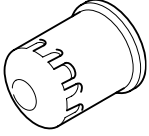
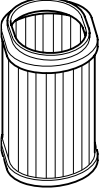

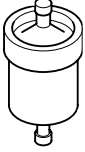
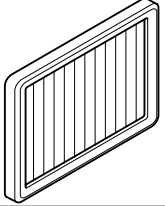
CITROËN XANTIA → 12/97

|  |  |  |  |  |  |
|---|---|---|---|---|---|
| (XU5JP) Ess 1,6 L | 1109 N3 | 96 144 871 | | | |
| (XU7JB-XU7JP) Ess 1,8 L Sauf 16S | 1109 J9 → 07/94 | | | | |
| (XU7JP4) Ess 1,8 L 16S | 1109 N3 | 1444 F4 □ 1444 A8 □ □ | | 1567 79 → 01/97 | |
| (XU10J2) Ess 2 L Sauf 16S | 1109 N3 1109 J9 → 07/94 | 96 144 871 | | 1567 85 01/97 → | |
| (XU10J2TE) Ess 2 L Turbo | 1109 N3 | 1444 F4 □ 1444 A8 □ □ | | | |
| (XU10J4) Ess 2 L 16S | 1109 N3 1109 J9 → 07/94 | 1444 F2 | | 1567 79 | |
| (XU10J4R) Ess 2 L 16S | 1109 N3 | 1444 F4 □ 1444 A8 □ □ | | 1567 79 → 01/97 1567 85 01/97 → | 6447 Z4 |
| (ES9J4) V6 3 L | 1109 N5 RP 1109 S8 | | 1567 85 | | |
| (XUD9) DI Atmo 1,9 L → 05/95 | 1109 N3 | 1444 F4 □ | 1906 43 | | |
| (XUD9) DI Atmo 1,9 L 06/95 → | 1109 J9 → 05/95 | 1444 F4 □ 1444 A8 □ □ | | | |
| (XUD9TE) DI Turbo 1,9 L → 09/95 | 1109 N3 | 1444 F4 | 1906 33 | | |
| (XUD9TE) DI Turbo 1,9 L 09/95 → | 1109 J9 | | | | |
| (XUD11BTE) DI Turbo 2,1L | 1109 N3 | 1444 F4 □ 1444 A8 □ □ | 1906 43 → 11/96 1906 33 → 11/96 1906 35 12/96 → RP 1906 55 | | |

□ Atmosphère normale : Normal atmosphere - Atmosfera normal - Atmosfera normal - Normale luftumgebung - Pressione atmosferica normal - Goed wegennet

□ □ Atmosphère poussières : Dusty atmosphere - Atmosfera polvorienta - Atmosfera poluida - Staubige luftumgebung - Pressione atmosferica polverosa - slecht wegennet (stoffig)

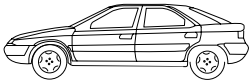
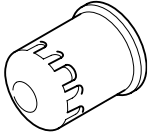
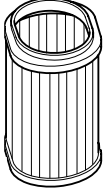
CITROËN XANTIA 12/97 →

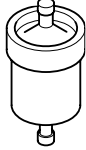
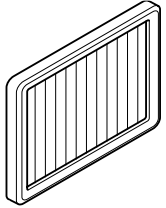
|  |  |  |  |  |  |
|---|---|---|--|---|---|
| (XU5JP) Ess 1,6 L | 1109 N3 | 96 144 871 | | 1567 85 | 6447 Z4 |
| (XU7JB-XU7JP) Ess 1,8 L Sauf 16S | | | | | |
| (XU7JP4) Ess 1,8 L 16S ★ | | 1444 F4 □ 1444 A8 □□ | | | |
| (XU7JP4) Ess 1,8 L 16S ★★ | | 1444 F4 | | | |
| (XU10J2) Ess 2 L Sauf 16S | | 96 144 871 | | | |
| (XU10J2TE) Ess 2 L Turbo | | 1444 F4 □ 1444 A8 □□ | | | |
| (XU10J4R) Ess 2 L 16S | | | | | |
| (ES9J4) V6 3 L | 1109 N5 RP 1109 S8 | | | | |
| (XUD9SD-XUD9TE) DI Turbo 1,9 L | 1109 N3 | | 1906 43 1906 33 | | |
| (DW10TD-DW10ATED) DI Turbo 2 L | 1109 R1 RP 1109 T1 1109 X2 | 1444 H5 □ 1444 H7 □□ | 1906 51 (Bosch) 12/98 → | | |
| (XUD11BTE) DI Turbo 2,1 L | 1109 N3 | 1444 F4 □ 1444 A8 □□ | 1906 55 | | |

- **Atmosphère normale** : Normal atmosphere - Atmosfera normal - Atmosfera normal - Normale luftumgebung - Pressione atmosferica normal - Goed wegennet
 □□ **Atmosphère poussières** : Dusty atmosphere - Atmosfera polvorienta - Atmosfera poluida - Staubige luftumgebung - Pressione atmosferica polverosa - slecht wegennet (stoffig)
 ★ **Dépol CEE 95L3** : Depol CEE 95L3 - Antipolucion CEE 95L3 - Despoluição CEE 95L3 - Abgasnorm CEE 95L3 - Depol CEE 95L3 - Milieunorm CEE 95L3
 ★★ **Dépol CEE 2000** : Depol CEE 2000 - Antipolucion CEE 2000 - Despoluição CEE 2000 - Abgasnorm CEE 2000 - Depol CEE 2000 - Milieunorm CEE 2000

CITROËN C5

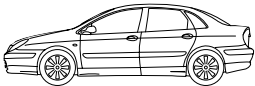
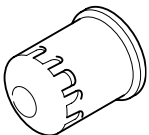
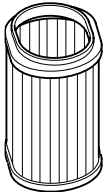
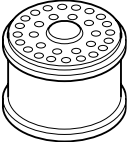
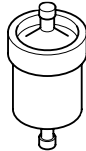
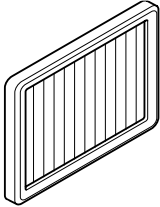

|  |  |  |  |  |  |
|--|---|---|---|---|---|
| (EW6J4) 1,6 L 16S | 1109 R1 RP 1109 T1 1109 X2 | 1444 T5 □ 1444 T6 □ □ | 1567 85 | 1567 85 | 6447 HT RP 6447 HV❖ |
| (EW7J4) 1,8 L 16S | | | | | |
| (EW10J4) 2 L 16S | | | | | |
| (EW10D) 2 L HPI | | | | | |
| (ES9J4S) 3 L V6 24S | 1109 N5 RP 1109 S8 | 1444 T9 □ 1444 T8 □ □ | | | 6447 HT RP 6447 HV❖ |
| (DW10TD) DI Turbo 2L | 1109 R1 RP 1109 T1 1109 X2 | 1444 T9 □ (sans FAP) → 06/2003 1444 T7 □ (sans FAP) 06/2003 → | 1906 51 (Bosch) → 06/2001 1906 77 (Mahle) 06/2001 → | | 6447 HV❖ |
| (DW10ATED) DI Turbo 2L | | 1444 T8 □ □ (sans FAP) 1444 F4 □ (avec FAP) | 1906 51 (Bosch) BVM → 04/2001 BVA → 03/2002 | | |
| (DW12TED4) DI Turbo 2L | | 1444 T7 □ 1444 T8 □ □ | 1906 77 (Mahle) BVM 05/2001 → BVA 04/2002 → | | |

❖ **Avec charbon actif** : With active carbon - Con carbon activo - Com carvão activo - Mit aktivkohle - Con carbone attivo - Met actieve koolstof

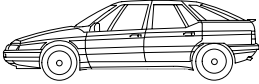
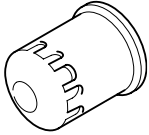
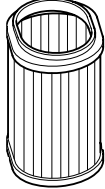

□ **Atmosphère normale** : Normal atmosphere - Atmosfera normal - Atmosfera normal - Normale luftumgebung - Pressione atmosferica normal - Goed wegennet

□ □ **Atmosphère poussières** : Dusty atmosphere - Atmosfera polvorienta - Atmosfera poluïda - Staubige luftumgebung - Pressione atmosferica polverosa - slecht wegennet (stoffig)

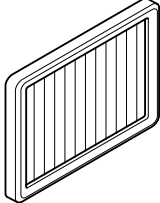
CITROËN XM

|  |  |  |  |  |  |
|---|---|---|---|---|---|
| Ess Sauf V6 → 06/94 | 1109 N3 1109 J9 | 94 01 444 108 | | SRV 000 503 (Carbu) | |
| Ess Sauf V6 06/94 → | 1109 N3 | | | 1567 78 (IE) → 02/98 | |
| (ZPJ-ZPJ4) V6 3 L | <i>1109 K7</i> RP 1109 S8 | | | 1567 78 | |
| (ES9J4) V6 3 L | <i>1109 N5</i> RP 1109 S8 | | | 1567 78 → 02/98 1567 85 02/98 → | |
| (XUD11A) DI Atmo 2,1 L → 06/94 | 1109 N3 | | 95 608 910 (Purflux) | | |
| (XUD11ATE) DI Turbo 2,1 L → 06/94 | 1109 J9 | | 94 01 906 148 (Roto Diesel) | | |
| (XUD11A) DI Atmo 2,1 L 07/94 → | 1109 N3 | | 95 608 910 | | |
| (XUD11ATE) DI Turbo 2,1 L 07/94 → | | | 1906 43 → 11/96 1906 33 → 11/96 <i>1906 35</i> 11/96 → RP 1906 55 | | |
| (XUD11BTE) DI Turbo 2,1 L | 1109 J9 → 05/95 | | 95 608 910 → 05/98 1906 53 06/98 → | | |
| (DK5ATE) DI Turbo 2,5 L | <i>1109 K7</i> RP 1109 S8 | | | | |

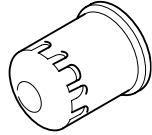
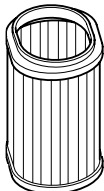
CITROËN C8

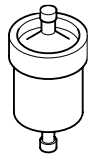
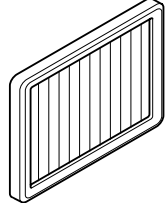
|  |  |  |  |  |  |
|---|---|--|---|---|---|
| (EW10J4) Ess 2 i L 16 S | 1109 T1 | 1444 W8 □ | | | 6447 LZ |
| (EW12J4) Ess 2,2 i L 16 S | 1109 X2 | 1444 CS □ □ | | 1567 85 | |
| (ES9J4S) Ess 3 i L | 1109 S8 | 1444 T7 □ | | | |
| (DW10ATED4) DI 2 L HDi | 1109 T1 | 1444 T7 □ (sans FAP) 1444 T8 □ □ (sans FAP) 1444 F4 (avec FAP) | 1906 77 | | |
| (DW12TED4) DI 2,2 L HDi | 1109 X2 | 1444 F4 ◆ 1444 F8 ◆ ◆ | | | |



◆ **Pays tempérés** : Temperate countries - Clima templado - Paises temperados - Gemässigte länder - Clima temperato - Landen met een gematigd

◆◆ **Pays chauds** : Hot countries - Paises calidos - Paises quentes - Tropische länder - Clima caldo - Warme landen

□ **Atmosphère normale** : Normal atmosphere - Atmosfera normal - Atmosfera normal - Normale luftumgebung - Pressione atmosferica normal - Goed weggennet

□ □ **Atmosphère poussières** : Dusty atmosphere - Atmosfera polvorienta - Atmosfera poluida - Staubige luftumgebung - Pressione atmosferica polverosa - slecht weggennet (stoffig)

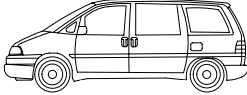
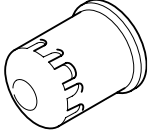
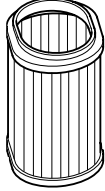
CITROËN EVASION

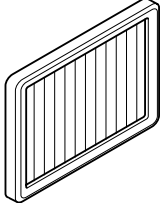
|  |  |  |  |  |  |
|---|---|---|---|---|---|
| (XU7JP) Ess 1,8 L | 1109 N3 | 1444 F4 | | 1567 85 | |
| (XU10J2) Ess 2 L | | | | 1567 78 → 06/96 | |
| (XU10J2TE) Ess 2 L Turbo | | | | 1567 85 06/96 → | |
| (XU10J4R) Ess 2 L 16S | | | | 1567 85 | |
| (EW10J4) Ess 2 L 16S | <i>1109 R1</i> RP 1109 T1 1109 X2 | 1444 F4 □ 1444 A8 □ □ | | | |
| (XUD9TE) DI Turbo 1,9 L | 1109 N3 | 1444 F4 | 1906 43 (Purflux) 1906 33 (Lucas) | | 6447 H0 (1) ○ 6447 H1 (2) ○ ○ |
| (DW10ATED) DI Turbo 2 L | <i>1109 R1</i> RP 1109 T1 1109 X2 | 1444 H5 □ → 07/99 | 1906 51 (Bosch) deo 1917 23 (1) | | |
| (DW10ATED4) DI Turbo 2 L | | 1444 R7 □ 07/99 → | 1906 51 (Bosch) deo 1917 23 (1) → 03/2001 | | |
| | | 1444 H7 □ □ | 1906 77 (Mahle) 04/2001 → | | |
| (XUD11BTE) DI Turbo 2,1 L | 1109 N3 | 1444 F4 | 1906 43 → 11/96 1906 33 → 11/96 1906 55 11/96 → | | |



○ Central : Central - Central - Central - Mitte - Centrale - Midden

○ ○ Latéral : Lateral - Lateral - Lateral - Seitlich - Laterale - Zijkant

□ Atmosphère normale : Normal atmosphere - Atmosfera normal - Atmosfera normal - Normale luftumgebung - Pressione atmosferica normal - Goed wegennet

□ □ Atmosphère poussières : Dusty atmosphere - Atmosfera polvorienta - Atmosfera poluida - Staubige luftumgebung - Pressione atmosferica polverosa - slecht wegennet (stoffig)

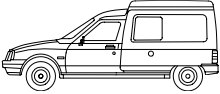
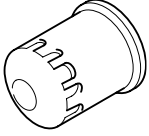
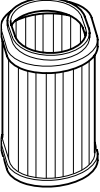
CITROËN C15

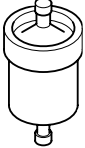
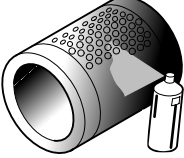
| | | | | | |
|---|---|---|--|---|---|
|  |  |  |  |  |  |
| (XU8) Ess 1 L | 95 638 829 | 79 01 144 559 NFP (Quillery) 94 01 445 798 (Mousse) | | | 9979 10 |
| (XW7-XY7) Ess 1,1 L - 1,4 L | 95 638 829 95 637 804 NFP | 79 01 144 551 (Quillery) 94 01 445 798 (Mousse) | | SRV 000 503 (Carbu) | |
| (TU9-TU1) Ess 1 L - 1,1 L | 1109 N3 1109 J9 → 06/94 | 95 619 441 | | 1567 79 (IE) → 05/95 | |
| (E1A-G1A) ESS 1118 - 1294 cm ³ | 94 01 109 798 NFP | | | 1567 85 (IE) 05/95 → | |
| (TU3) Ess 1,4 L | 1109 N3 1109 J9 → 06/94 | 95 619 441 * 1444 A7 * * | | | |
| (XUD7) DI Atmo 1,8 L | 1109 N3 1109 J9 → 05/95 | 94 01 445 898 Sauf Dépol CEE 95L3 ☆ 1444 G1 Dépol CEE 95L3 ★ | 1906 32 Roto Diesel → 04/92 5 414 362 (Purflux) → 04/92 1906 33 04/92 → | | 9979 10 |
| (DW8-DW8B) DI Atmo 1,9 L | 1109 R1 RP 1109 T1 1109 X2 | 1444 G1 | 1906 49 | | |

* Carter cylindre aluminium : Aluminium cylinder block - Bloque cilindros aluminio - Cilindro do carter em aluminio - Motorgehaeuse aluminium - Carter cilindri alluminio - Motorcarter Aluminium





* * Carter cylindre fonte : Cast iron cylinder block - Bloque cilindros fundicion - Cilindro do carter fundido - Motorgehaeuse stahlguss - Carter cilindri gijisa - Motorcarter gietijzer

Huile pour mousse de filtre à air sec : Air filter lubricant - Aceite lubricante del filtro aire seco - Oleo para espuma de filtro a ar seco - Oel fuerluftfiltereinsatz - Olio per spugna filtro aria a secco - Olie voor droge filterpatronen

☆ Sauf dépol CEE 95L3 : Except depol CEE 95L3 - Salvo antipolucion CEE 95L3 - Salvo Despolação CEE 95L3 - Ausser abgasnorm CEE 95L3 - Salvo depol CEE 95L3 - Zonder milieunorm CEE 95L3

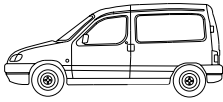
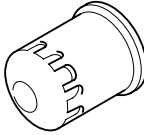
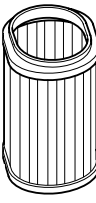
★ Dépol CEE 95L3 : Depol CEE 95L3 - Antipolucion CEE 95L3 - Despolação CEE 95L3 - Abgasnorm CEE 95L3 - Depol CEE 95L3 - Milieunorm CEE 95L3

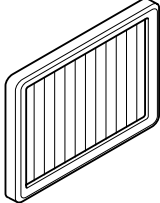
CITROËN BERLINGO (VP-VU)

|  |  |  |  |  |  |
|---|---|---|--|---|---|
| (VU) (TU1M+) Ess 1,1 L | 1109 N3 | 1444 A7 | | 1567 85 1635 P4  (GPL) | 6447 Z4 → 12/2000 (CAG) 6447 HP 12/2000 → (CAG) 6447 Z4 (CAD) |
| (VU) (TU1JP) 09/2000 → Ess 1,1 L | 1109 R7 | 1444 E5 | | 1567 85 | |
| (VP) (TU3-2) Ess 1,4 L | 1109 N3 | 1444 A7 | | | |
| (VP) (TU3JP) 09/2000 → Ess 1,4 L | 1109 R7 | 1444 E5 | | 1567 85 1635 P5  (GPL) | |
| (VP) (TU5JP4) 11/2000 → Ess 1,6 L 16S | | 1444 V3 ▲ 1444 V5 ▲▲ | | 1567 85 | |
| (VP) (XU7JB) Ess 1,8 L | 1109 N3 | 96 144 871 | | | |
| (VP-VU) (XUD7-XUD9) DI Atmo 1,8 L 1,9 L | | 1444 F5 → 11/96 1444 G1 11/96 → | 1906 43 1906 33 | | |
| (VP-VU) (DW8) DI Atmo 1,9 L | | | 1444 G1 | 1906 49 | |
| (VP-VU) (DW8B) DI Atmo 1,9 L | 1109 R1 RP 1109 T1 | 1444 H2 | | | |
| (VP-VU) (DW10TD) DI Turbo 2 L | 1109 X2 | 1444 R6 □ 1444 J0 □□ | 1901 69 (Bosch) 1906 77 (Mahle) | | |

VU (véhicule utilitaire) : Commercial vehicle - Vehículo utilitario - Veículo utilitário - Nutzfahrzeug - Veicoli commerciali - bedrijfsauto

VP (véhicule particulier) : Passenger vehicle - Vehículo particular - Veículo particular - PKW - Autovettura - personenauto

▲ Montage sans préfiltre : Without pre-filter assembly - Montaje sin prefiltro - Montagem sem prefiltro - Montage ohne vorfilter - Montaggio senza prefiltro - Montage zonder vóórfilter

▲▲ Montage avec préfiltre : With pre-filter assembly - Montaje con prefiltro - Montagem com prefiltro - Montage mit vorfilter - Montaggio con prefiltro - Montage met vóórfilter

□ Atmosphère normale : Normal atmosphere - Atmosfera normal - Atmosfera normal - Normale luftumgebung - Pressione atmosferica normal - Goed wegennet

□□ Atmosphère poussières : Dusty atmosphere - Atmosfera polvorienta - Atmosfera poluida - Staubige luftumgebung - Pressione atmosferica polverosa - slecht wegennet (stoffig)

CITROËN BERLINGO II (VP-VU)

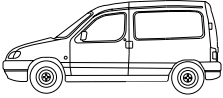
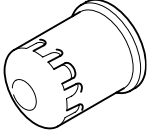
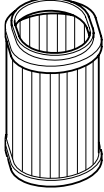
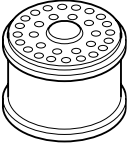
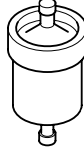
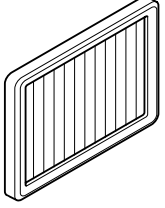
| | | | | | | |
|---|---|---|---|---|---|-------------------------|
|  |  |  |  |  |  | |
| (VP-VU) (TU1JP-TU3JP) Ess 1,1 L - 1,4 L | 1109 R7 | 1444 X0 □ 1444 X4 □ □ | | 1567 85 | 6447 HP (CAG) | |
| (TU5JP4) Ess 1,6 L 16 S | | 1444 X1 □ 1444 X4 □ □ | | | | |
| (VP-VU) (DW8B) DI Atmo 1,9 L | 1109 T1 1109 X2 | 1444 CC | 1906 49 | | | 6447 Z4 (CAD) |
| (VP-VU) (DW10TD) DI Turbo 2 L | 1109 R1 RP 1109 T1 1109 X2 | 1444 CC □ 1444 CK □ □ | 1906 77 | | | |



VU (véhicule utilitaire) : Commercial vehicle - Vehículo utilitario - Veículo utilitário - Nutzfahrzeug - Veicoli commerciali - bedrijfsauto

VP (véhicule particulier) : Passenger vehicle - Vehículo particular - Veículo particular - PKW - Autovetture - personenauto

□ Atmosphère normale : Normal atmosphere - Atmosfera normal - Atmosfera normal - Normale luftumgebung - Pressione atmosferica normal - Goed wegennet

□ □ Atmosphère poussières : Dusty atmosphere - Atmosfera polvorienta - Atmosfera poluida - Staubige luftumgebung - Pressione atmosferica polverosa - slecht wegennet (stoffig)

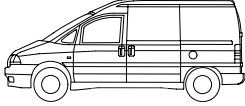
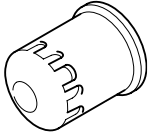
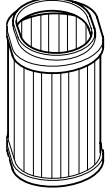
CITROËN JUMPY

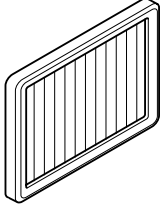
| | | | | | |
|---|---|---|--|---|---|
|  |  |  |  |  |  |
| (1580 SPI) Ess 1,6 L | 1109 K9 | 1444 F4 | | 1567 78 → 06/96 1567 85 06/96 → | |
| (EW10J4) Ess 2 L 16S | <i>1109 R1</i> RP 1109 T1 1109 X2 | 1444 F4 □ 1444 A8 □□ | | 1567 85 | |
| (XUD9-XUD9TE) DI 1,9 L | 1109 N3 | 1444 F4 | 1906 43 1906 33 | | |
| (DW8-DW8B) DI Atmo 1,9 L | | 1444 F4 ▲ □ 1444 A8 ▲▲ □□ | 1906 49 | | |
| (DW10-DW10ATED) (DW10ATED4) (DW10BTEDW4) DI Turbo 2 L | <i>1109 R1</i> RP 1109 T1 1109 X2 | 1444 R7 □ 1444 H7 □□ | 1906 51 (Bosch) → 04/2001 (deo 1917 23 (1) → 12/01) 1906 77 (Mahle) 04/2001 → | | |

▲ **Montage sans préfiltre** : Without pre-filter assembly - Montaje sin prefiltro - Montagem sem prefiltro - Montage ohne vorfilter - Montaggio senza prefiltro - Montage zonder vóórfilter
 ▲▲ **Montage avec préfiltre** : With pre-filter assembly - Montaje con prefiltro - Montagem com prefiltro - Montage mit vorfilter - Montaggio con prefiltro - Montage met vóórfilter
 □ **Atmosphère normale** : Normal atmosphere - Atmosfera normal - Atmosfera normal - Normale luftumgebung - Pressione atmosferica normal - Goed wegennet
 □□ **Atmosphère poussières** : Dusty atmosphere - Atmosfera polvorienta - Atmosfera poluída - Staubige luftumgebung - Pressione atmosferica polverosa - slecht wegennet (stoffig)

CITROËN JUMPER

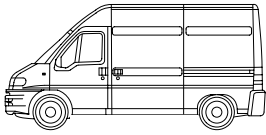
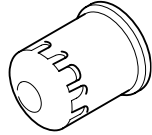
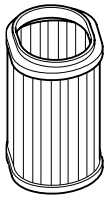
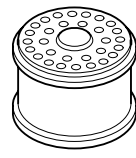
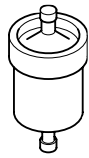
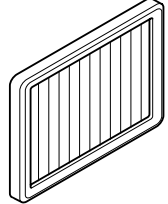

| | | | | | |
|--|---|---|---|---|---|
|  |  |  |  |  |  |
| (XU102C) Ess 2 L | 1109 N3 | | | 1567 92 | |
| (XU10J2) Ess 2 L | 1109 J9 → 07/94 | 1444 99 | | 1567 75 → S 15408415 1567 89 S 15408416 → | |
| (XUD9) DI Atmo 1,9 L | 1109 N3 | 1444 A1 | 1906 32 → 02/99 (Lucas) | | 6447 J0 |
| (XUD9TE) DI Turbo 1,9 L | 1109 J9 → 05/95 | | 1906 61 03/99 → (Bosch) (bouchon M8) | | |
| (DW10TD) DI Turbo 2 L | <i>1109 R1</i> RP 1109 T1 1109 X2 | 1444 99 | 1906 88 03/99 → (Bosch) (bouchon M10) | 1906 67 | |
| (DJ5) DI Atmo 2,5 L | | 1444 A1 ■ 1444 99 ■ ■ | 1906 32 → 02/99 (Lucas) | | |
| (DJ5T-DJ5TED) DI Turbo 2,5 L | <i>1109 N5</i> RP 1109 S8 | | 1906 61 03/99 → (Bosch) (bouchon M8) | | |
| (SOFIM) DI TT 2,8 L | | 1444 99 | 1906 88 03/99 → (Bosch) (bouchon M10) | 1906 63 | |
| (SOFIM) HDi 2,8 L | 1109 Q1 | | | 1906 67 | |

Bouchon M8 : Cover M8 - Tapon M8 - Bujon M8 - Stopfen M8 - Tappo M8 - Dop M8

■ **Sauf atmosphère poussières Sauf pays chauds** : Except dusty atmosphere Except hot countries - Salvo atmosfera polvorientas Salvo paieis caldi os - Salvo atmosfera poluida Salvo paisas quentes - Asser staubige luftumgebung Asser heisse laender - Salvo pressione atmosferica polverosa Salvo paesi caldi - Behalve slecht wegennet (stoffig) Behalve warme landen

■ ■ **Atmosphère poussières Pays chauds** : Dusty atmosphere Hot countries - Atmosfera polvorientas Paieis caldi os - Atmosfera poluida Paisas quentes - Staubige luftumgebung Heisse laender - Pressione atmosferica polverosa Paesi caldi - Slecht wegennet (stoffig) Warme landen

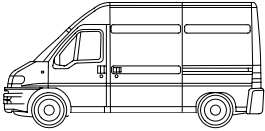
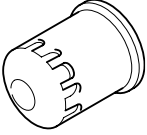
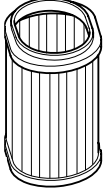
CITROËN JUMPER II

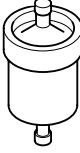
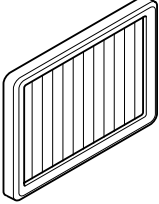
| | | | | | |
|---|---|---|--|---|---|
|  |  |  |  |  |  |
| (XU10J2) Ess 2 L | 1109 N3 | 1444 99 | | - | 6447 J0 |
| (DW10TD) DI Turbo 2 L | 1109 R1 RP 1109 T1 1109 X2 | | | | |
| (DW12TED) DI Turbo 2,2 L | 1109 T1 | | 1906 67 | | |
| (SOFIM) DI 2,8 L | 1109 Q1 | | | | |
| (SOFIM) HDi 2,8 L | | | | | |

Bouchon M8 : Cover M8 - Tapon M8 - Bujon M8 - Stopfen M8 - Tappo M8 - Dop M8

■ **Sauf atmosphère poussières Sauf pays chauds** : Exept dusty atmosphere Exept hot countries - Salvo atmosfera polvorientas Salvo paieis caldi os - Salvo atmosfera poluida Salvo paises quentes - Asser staubige luftumgebung Asser heisse laender - Salvo pressione atmosferica polverosa Salvo paesi caldi - Behalve slecht wegennet (stoffig) Behalve warme landen

■ **Atmosphère poussières Pays chauds** : Dusty atmosphere Hot countries - Atmosfera polvorientas Paieis caldi os - Atmosfera poluida Paises quentes - Staubige luftumgebung Heisse laender - Pressione atmosferica polverosa Paesi caldi - Slecht wegennet (stoffig) Warme landen

CITROËN C25

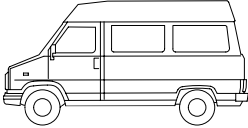
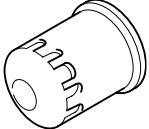
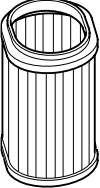
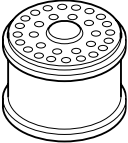
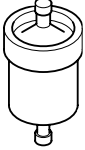
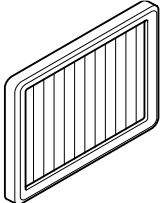
| | | | | | |
|---|---|---|---|---|---|
|  |  |  |  |  |  |
| Ess | 79 10 031 245 NFP 1109 N3 | 94 01 445 638 (Lautrette) 94 01 445 688 (AOP) <input type="checkbox"/> 94 01 445 268 (AOP) <input type="checkbox"/> | | SRV 000 503 | |
| DI 1,9 L | 1109 J9 07/83 → | 1444 A1 | 1906 32 → 121 750 94 01 906 148 121 750 → | | |
| (M705T-XT) DI Turbo 1,9 L | 1109 L3 RP 1109 W7 | | ZF 09 941 058 | | |
| DI 2,5 L | 5 443 746 → 10/83 95 495 251 10/83 → | ZF 04 434 852 → 121 749 95 643 756 121 750 → | 1906 32 → 121 750 94 01 906 148 121 750 → | | |

Atmosphère normale : Normal atmosphere - Atmosfera normal - Atmosfera normal - Normale luftumgebung - Pressione atmosferica normal - Goed wegennet

Atmosphère poussières : Dusty atmosphere - Atmosfera polvorienta - Atmosfera poluida - Staubige luftumgebung - Pressione atmosferica polverosa - slecht wegennet (stoffig)



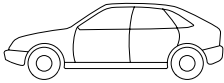
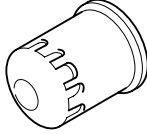
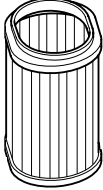

2CV - DYANE - AMI - MEHARI

| | | |
|---|---|---|
|  |  |  |
| 2 CV | 75 518 393 75 491 083 | AM 1715D (Lautrette) 5 490 363 (Miofiltre) → 05/77 5 508 266 □□ 95 546 429 (Quillery) 05/77 → |
| Dyane 4 | 75 518 393 | AZ 1715 |
| Dyane 6 | | 95 546 429 → 03/77 5 490 363 03/77 → |
| AMI 8 | 75 518 393 | AM 1715C NFP |
| AMI SUPER | | GX 03 183 01A NFP → 01/74 95 574 659 NFP 01/74 → |
| MEHARI | 75 518 393 | AZ 1715 → 07/78 5 508 266 07/78 → |

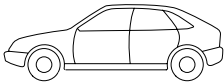
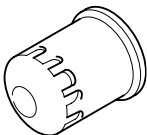
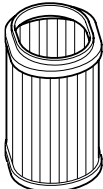

□ **Atmosphère normale** : Normal atmosphere - Atmosfera normal - Atmosfera normal - Normale luftumgebung - Pressione atmosferica normal - Goed wegennet

□□ **Atmosphère poussières** : Dusty atmosphere - Atmosfera polvorienta - Atmosfera poluida - Staubige luftumgebung - Pressione atmosferica polverosa - slecht wegennet (stoffig)

LN-LNA - VISA - AXEL

| | | | | | |
|---|---|---|---|---|---|
|  |  |  |  |  |  |
| LN | 75 518 393 | 95 546 429 | | 5 490 862 | |
| LNA (652 cm³) | | 95 558 218 | | | |
| LNA (1124 cm³) | 95 638 829 | 79 01 144 551 (Miofiltre) 79 01 144 561 NFP (Lautrette) 94 01 445 798 (Mousse) | | SRV 000 503 | 9979 10 |
| Visa (652 cm³) | 75 518 393 | 95 558 218 | | 5 490 862 | |
| Visa (954 - 1124 1219 - 1360 cm³) | 95 638 829 | 79 01 144 551 (Miofiltre) 79 01 144 561 NFP (Lautrette) 94 01 445 798 (Mousse) | | SRV 000 503 (Carbu) | 9979 10 |
| Visa Chrono | | 79 01 144 570 NFP | | | 1567 79 (IE) |
| Visa GTI | 1109 N3 | 94 01 445 968 NFP | | | |
| Visa DI | | 94 01 445 898 | 5 414 362 (Purflux) 1906 32 (Roto Diesel) | | 9979 10 |
| Axel Sauf 12 TRS | 95 495 894 | 95 549 828 NFP | | SRV 000 503 | |
| Axel 12 TRS | | 95 574 084 | | | |

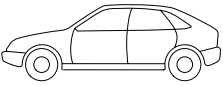
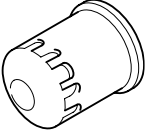
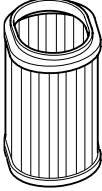
GS-GSA - CX

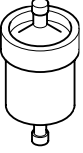
| | | | | |
|---|---|---|---|---|
|  |  |  |  |  |
| GS | 95 495 894 | GX 03 183 01A → 01/74 NFP 95 574 659 01/74 → NFP | | SRV 000 503 |
| GSA 1130 cm³ | | 95 574 084 | | |
| GSA 1300 cm³ | | 95 574 659 → 05/80 NFP 95 574 084 05/80 → | | |
| CX Ess 2 L - 2,2 L → 07/79 | 5 443 746 | 95 600 490 NFP | | SRV 000 503 (Carbu) 1567 79 (IE) |
| CX Ess 2 L - 2,2 L 07/79 → | 1109 N3 | 95 495 229 | | |
| CX Ess 2,35 L - 2,5 L | 1109 J9 11/86 → | 95 605 500 | | |
| CX DI Atmo 2,2 L | 5 443 746 → 10/83 | 5 483 333 NFP | 95 608 910 (Purflux) | |
| CX DI Atmo 2,5 L | | 5 483 333 NFP 95 572 533 06/81→ | 1906 32 → 11/83 94 01 906 148 11/83 → (Roto Diesel) | |
| CX DI Turbo | | 95 495 251 11/83 → | 95 600 491 (CH) (A) 95 633 997 NFP | |

ACADIANE

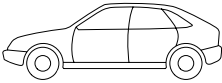
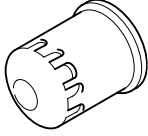
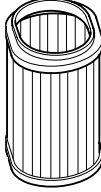
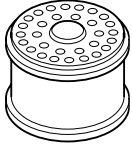
| | | | |
|---|---|---|---|
|  |  |  |  |
| Acadiane | 75 518 393 | 5 490 363 → 07/87 95 546 429 07/87 → | |



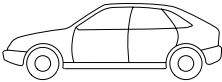
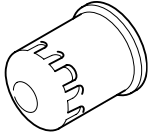
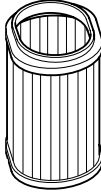
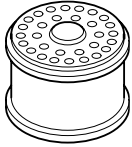



C35

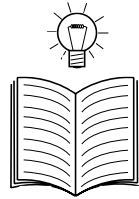
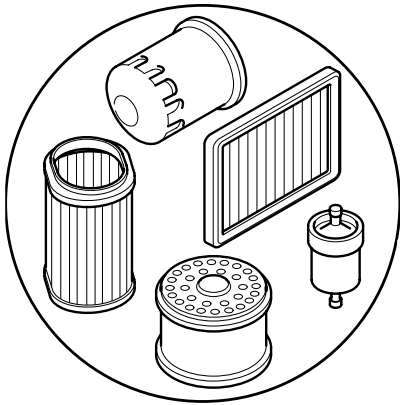

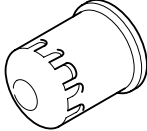

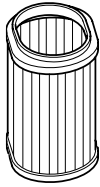

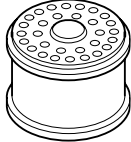

| | | | |
|---|--|--|--|
|  |  |  |  |
| Ess | 5 443 746 11/73 → 04/86 1109 N3 04/86 → | 5 435 586 NFP | |
| DI 2,2 L → 01/80 | 5 443 746 | 5 416 440 ▼ | 5 414 362 → 01/80 (Purflux) |
| DI 2,5 L 01/80 → 05/81 | | | 95 608 910 10/83 → (Purflux) |
| DI 2,5 L 05/81 → | 1109 N3 11/86 → | 5 416 441 ▼▼ NFP | 1906 32 03/75 → 11/83 (Roto Diesel) |
| | 5 443 746 → 07/86 | | 94 01 906 148 11/83 → (Roto Diesel) |
| | 1109 J9 07/86 → | | |

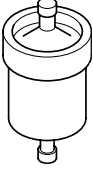
▼ Supérieur : Upper - Superior - Superior - Oben - Superiore - Boven

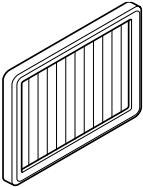
▼▼ Inférieur : Lower - Inferior - Inferior - Unten - Inferiore - Onder

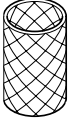

| | | | | | |
|--|---|--|---|---|---|
|  |  |  |  |  |  |
| 1109 J9 | 4-9-10-14-15-16 19-22-26-28-31-32 | 1444 99 | 26-27 | 1901 67 | 6 |
| 1109 K9 | 25 | 1444 A1 | 26-28 | 1901 68 | 6-7 |
| 1109 N3 | 4-8-9-10-11-12-14-15 16-17-19-21-22-23 25-26-27-28-30-31-32 | 1444 A5 | 4-8-11 | 1901 69 | 23 |
| 1109 Q1 | 26-27 | 1444 A7 | 4-8-9-11-13-22-23 | 1901 73 | 5-6-7 |
| 1109 R7 | 5-6-7-8-12-13-23-24 | 1444 A8 | 16-17-21-25 | 1906 32 | 22-26-28-30-31-32 |
| 1109 S8 | 16-17-18-19-20-26 | 1444 E5 | 8-9-11-23 | 1906 33 | 10-11-15-16-17 19-21-22-23-25 |
| 1109 T1 | 11-12-13-17-18-20-21 22-23-24-25-26-27 | 1444 E7 | 10-11-12 | 1906 40 | 4-8-10-11 |
| 1109 T3 | 5-6-7-12 | 1444 E8 | 8 | 1906 42 | 4-8-10-11 |
| 1109 W7 | 27-28 | 1444 F2 | 9-10-11-16 | 1906 43 | 10-11-15-16 17-19-21-23-25 |
| 1109 X2 | 11-12-13-17-18-20-21 22-23-24-25-26-27 | 1444 F4 | 4-10-14-15-16 17-18-20-21-25 | 1906 49 | 11-12-22-23-24-25 |
| 1109 X4 | 6 | 1444 F5 | 10-11-23 | 1906 51 | 11-12-13-17 18-21-25 |
| 5 443 746 | 28-31-32 | 1444 F6 | 9-11 | 1906 53 | 19 |
| 75 491 083 | 29 | 1444 G1 | 11-22-23 | 1906 55 | 16-17-19-21 |
| 75 518 393 | 29-30-32 | 1444 G2 | 9-11 | 1906 61 | 26 |
| 95 495 251 | 28-31 | 1444 H2 | 10-11-23 | 1906 63 | 26 |
| 95 495 894 | 30-31 | 1444 H5 | 17-21 | 1906 67 | 26-27 |
| 95 638 829 | 14-22-30 | 1444 H7 | 17-21-25 | 1906 77 | 12-13-18-20-21-23-24-25 |
| | | 1444 J0 | 11-23 | 1906 88 | 26 |
| | | 1444 J3 | 12-13 | 5 414 362 | 22-30-32 |
| | | 1444 J5 | 12-13 | 95 608 910 | 15-19-31-32 |
| | | 1444 R1 | 12-13 | 94 01 906 148 | 15-19-28-31-32 |
| | | 1444 R3 | 12-13 | ZF 09 941 058 | 28 |
| | | 1444 R6 | 11-23 | | |
| | | 1444 R7 | 21-25 | | |
| | | 1444 T5 | 18 | | |
| | | 1444 T6 | 18 | | |
| | | 1444 T7 | 18-20 | | |
| | | 1444 T8 | 18-20 | | |
| | | 1444 T9 | 18 | | |
| | | 1444 V0 | 8-16 | | |
| | | 1444 V3 | 23 | | |
| | | 1444 V5 | 23 | | |
| | | 1444 W8 | 20 | | |
| | | 1444 X0 | 5-6-7-24 | | |
| | | 1444 X1 | 5-6-7-24 | | |
| | | 1444 X3 | 5-6-7-12 | | |
| | | 1444 X4 | 5-6-7-24 | | |
| | | 1444 X5 | 6 | | |
| | | 1444 X7 | 5-6-7-12 | | |
| | | 1444 CC | 24 | | |
| | | 1444 CK | 24 | | |
| | | 1444 CS | 20 | | |
| | | 5 416 440 | 32 | | |
| | | 5 490 363 | 29-32 | | |
| | | 5 508 266 | 29 | | |
| | | 95 495 229 | 31 | | |
| | | 95 546 429 | 29-30-32 | | |
| | | 95 558 218 | 30 | | |
| | | 95 572 533 | 31 | | |
| | | 95 574 084 | 30-31 | | |
| | | 95 600 491 | 31 | | |
| | | 95 605 128 | 13-15 | | |
| | | 95 605 500 | 31 | | |
| | | 95 619 441 | 4-8-13-22 | | |
| | | 95 643 756 | 28 | | |
| | | 95 658 435 | 9 | | |
| | | 96 144 871 | 9-11-16-17-23 | | |
| | | 79 01 144 551 | 14-22-30 | | |
| | | 94 01 444 108 | 19 | | |
| | | 94 01 445 268 | 28 | | |
| | | 94 01 445 638 | 28 | | |
| | | 94 01 445 688 | 28 | | |
| | | 94 01 445 798 | 13-22-30 | | |
| | | 94 01 445 898 | 22-30 | | |
| | | AM 1715D | 29 | | |
| | | AZ 1715 | 29 | | |
| | | ZF 04 434 852 | 28 | | |

| | | | | | |
|--|--|--|--|---|---|
|  |  |  |  |  |  |
| 1567 75 1567 78 1567 79 1567 85 1567 89 1567 92 1567 A5 5 490 862 SRV 000 503 | 26 13-21-25 4-9-10-14-15 16-17-22-30-31 7-8-9-10-11-12-13-16 18-19-20-21-23-24-25 26 26 5-6 30 4-9-14-15-19 22-28-30-31 | 6441 G9 6447 FF 6447 FG 6447 H0 (1) 6447 H1 (2) 6447 HP 6447 HT 6447 HV 6447 J0 6447 LN 6447 LZ 6447 NT 6447 NV 6447 Z4 | 8 13 11-12 21 21 12-23-24 18 18 26-27 13 20 5-6-7 5-6-7 11-12-16-17-23-24 | 9979 10 | 14-22-30 |
| | | | | | |
|  <p>(GPL)</p> |  | | | | |
| 1635 P4 1635 P5 | 8-12-23 11-23 | | | | |
| | | | | | |

☞ Pour connaître les dernières dates de mise à jour, voir DOC FLASH : DIF/DOC/MKSP

DROITS DE PROPRIÉTÉ

F "Les droits de propriété intellectuelle relatifs aux informations techniques contenues dans cette brochure appartiennent exclusivement au Constructeur. Toute reproduction et/ou diffusion de tout ou partie de ces informations sont interdites sans autorisation écrite préalable du Constructeur."
"Les informations techniques contenues dans la présente documentation sont destinées exclusivement aux professionnels de la réparation automobile. Dans certains cas, ces informations peuvent concerner la sécurité des véhicules. Elles seront utilisées par les réparateurs automobiles auxquels elles sont destinées, sous leur entière responsabilité, à l'exclusion de celle du Constructeur."
"Les informations techniques figurant dans cette brochure peuvent faire l'objet de mises à jour en fonction de l'évolution des caractéristiques des modèles de chaque gamme.
Nous invitons les réparateurs automobiles à se mettre en rapport périodiquement avec le Constructeur/avec son réseau, pour se procurer les mises à jour nécessaires."

☞ To see the latest update refer to DOC FLASH : DIF/DOC/MKSP

PROPERTY RIGHTS

GB "The intellectual copyrights relating to the technical information contained in this brochure are the exclusive property of the Manufacturer. Any reproduction and/or distribution of all or part of this information is forbidden without the Manufacturer's preliminary written authorisation."
"The technical information contained in this documentation is intended exclusively for automobile repair professionals. In certain cases, the information may relate to vehicle safety.
It will be used by the automobile repairers to whom it is addressed, on their full responsibility, to the exclusion of the Manufacturer's liability."
"The technical information that figures in this brochure may be updated in accordance with the changing features of models in each range.
We would request automobile repairers to get in touch with the Manufacturer/the network at regular intervals, to obtain the necessary updates."

☞ Para conocer las últimas fechas de puesta al día, ver DOC FLASH : DIF/DOC/MKSP

DERECHOS DE PROPIEDAD

E "Los derechos de propiedad intelectual relativos a las informaciones técnicas que figuran en este folleto pertenecen exclusivamente al Constructor. Se prohíbe toda reproducción y/o difusión de la totalidad o parte de estas informaciones sin autorización previa y por escrito del Constructor."
"Las informaciones técnicas que figuran en la presente documentación están destinadas exclusivamente a los profesionales de la reparación de automóviles. En ciertos casos, pueden afectar a la seguridad de los vehículos.
Serán utilizadas por los reparadores de automóviles, a quienes están destinadas, bajo su entera responsabilidad, excluyéndose la del Constructor."
"Las informaciones técnicas que figuran en este folleto pueden ser objeto de actualizaciones en función de la evolución de las características de los modelos de cada gama.
Invitamos a los reparadores de automóviles a ponerse en contacto periódicamente con el Constructor/con su red, para conseguir las actualizaciones necesarias."

☞ Para saber as últimas datas de actualizaçã, ver DOC FLASH : DIF/DOC/MKSP

DIREITOS DE PROPRIEDADE

P "Os direitos de propriedade intelectual relativos às informações técnicas contidas nesta brochura pertencem exclusivamente ao Construtor. Qualquer reprodução e/ou difusão da totalidade ou parte destas informações são proibidas sem a autorização prévia e escrita do Construtor."
"As informações técnicas contidas na presente documentação destinam-se exclusivamente aos profissionais da reparação automóvel. Em certos casos, estas informações podem referir-se à segurança dos veículos.
Serão utilizadas pelos reparadores automóvel a que se destinam, sob a sua total responsabilidade, excluindo a responsabilidade do Construtor."
"As informações técnicas que figuram nesta brochura podem ser objecto de actualizações consoante a evolução das características dos modelos de cada gama.
Os reparadores automóvel são convidados a entrarem periodicamente em contacto com o Construtor/com a sua rede, para obterem as actualizações necessárias."

☞ Die Daten der aktuellen Ausgaben finden Sie in : DOC FLASH : DIF/DOC/MKSP

EIGENTUMSRECHTE

D "Die Rechte auf geistiges Eigentum in Verbindung mit den in der vorliegenden Broschüre enthaltenen technischen Informationen stehen ausschließlich dem Hersteller zu. Jede vollständige oder teilweise Reproduktion und/oder Verbreitung dieser Informationen sind ohne vorherige schriftliche Genehmigung des Herstellers verboten."
"Die in der vorliegenden Dokumentation enthaltenen technischen Informationen sind ausschließlich für Autoreparaturfachleute bestimmt. In einigen Fällen können diese Informationen die Sicherheit der Fahrzeuge betreffen.
Sie werden von den Kraftfahrzeughandwerkern, für die sie bestimmt sind, in ihrer eigenen Verantwortung benutzt, unter Ausschluss der Verantwortung des Herstellers."
"Die in dieser Broschüre enthaltenen technischen Informationen können je nach Fortentwicklung der verschiedenen Modelle in jeder Produktreihe aktualisiert werden.
Wir fordern die Kraftfahrzeughandwerker auf, sich regelmäßig an den Hersteller/an sein Vertriebsnetz zu wenden, um sich die erforderlichen Aktualisierungen zu beschaffen".

☞ Per conoscere l'ultima data agglomeramento vedere DOC FLASH : DIF/DOC/MKSP

DIRITTI DI PROPRIETÀ

I "I diritti di proprietà intellettuale riguardanti le informazioni tecniche contenute nel presente manuale appartengono esclusivamente al Costruttore. Qualsiasi riproduzione e/o diffusione di tutto o parte di queste informazioni sono vietate senza autorizzazione preventiva scritta del Costruttore."
"Le informazioni tecniche contenute nella presente documentazione sono destinate esclusivamente agli autoriparatori. In alcuni casi, queste informazioni possono riguardare la sicurezza dei veicoli.
Esse verranno utilizzate dagli autoriparatori ai quali esse sono destinate sotto la loro piena responsabilità, ad esclusione di quella del Costruttore."
"Le informazioni tecniche contenute nel presente manuale possono essere soggetto ad aggiornamenti in funzione dell'evoluzione delle caratteristiche dei modelli di ogni gamma.
Invitiamo gli autoriparatori a mettersi in contatto periodicamente con il Costruttore/la sua rete, per procurarsi gli aggiornamenti necessari."

☞ Voor de laatste versiedatum, zie DOC FLASH : DIF/DOC/MKSP

EIGENDOMSRECHT

NL "Het individuele eigendomsrecht betreffende technische informatie die in deze brochure staat vermeld behoort exclusief aan de Fabrikant. Alle reproductie en/of verspreiding van alles of een gedeelte van deze informatie is verboden zonder voorafgaande, schriftelijke toestemming van de Fabrikant."
"De technische informatie die in deze documentatie staat vermeld is alleen bestemd voor vakmensen in de branche van de automobielreparatie. In bepaalde gevallen kan deze informatie betrekking hebben op de veiligheid van de wagens.
Deze wordt gebruikt door automobielreparateurs waarvoor zij is bestemd, onder hun volledig verantwoordelijkheid, waardoor die van de Fabrikant vervalt."
"De technische informatie die in deze brochure staat vermeld kan onderhevig zijn aan aanvullingen als gevolg van een ontwikkeling in de technische gegevens van de modellen van elke serie.
Wij vragen de automobielreparateurs zich regelmatig met de Fabrikant of zijn netwerk in verbinding te stellen, om deze noodzakelijke aanvullingen te verkrijgen."