

# ILLUSTRATIONS

INDEX OF ILLUSTRATIONS

COMPONENT	No. of Illustration	DESCRIPTION
ENGINE .....	1	Longitudinal section.
	2	Cross section.
	3	Assembly of valve rockers.
	4	Valve seats.
	5	Fitting the valves.
	6	Calibration of springs.
	7	Cylinder head. Sequence of tightening screws.
	8	Replacement of valve guides.
	9	Replacement of valve guides (tools).
	10	Oil pump.
	11	Adjustment of the oil pump.
	12	Fitting cylinder barrel joints.
	13	Piston and crankshaft line.
	14	Assembly of the oil seals.
	15	Setting the timing wheels.
	16	Various tools.
	17	Various tools.
	18	Stands for dismantled engine.
	19	Stand for dismantled engine-gearbox assembly.
	20	Adjustment of the position of the high pressure pump.
	21	Checking the distance between support and crossmember.
	22	Adjusting the longitudinal position of rear engine supports.
	23	Adjusting the height of rear engine supports.
	24	Adjusting the centres of rear engine supports.
	25	Spanners for adjustment of rear engine supports.
	26	Solex carburettor 34 PBIC.
	27	Accelerator control.
	28	MIOFILTER air filter.
	29	VOKES air filter.
	30	Section of GUIOT pump.
	31	Petrol pump (inspection for leaks).
	32	SEV distributor.
	33	DUCELLIER distributor.
	34	Distributor.
	35	Water pump.
	37	Water pump. Various tools.
	CLUTCH .....	38
39		Adjustment of the toggles.
40		Adjustment of the toggles
41		Clutch control.

COMPONENT	No. of Illustration	DESCRIPTION
GEARBOX .....	42	Removal and replacement.
	43	Assembly.
	44	Shafts.
	44 A	Assembly of pinions.
	45	Differential.
	46	Cover (levers operating the selector shafts).
	47	Cover.
	48	First speed selector lever.
	49	Clutch housing.
	50	Adjustment of crown wheel and bevel pinion.
	51	Adjustment of the differential bearings.
	52	Differential bearings (extraction and fitting).
	53	Stand for gearbox for use on bench.
	54	Various tools.
	55	Various tools.
	56	Assembly of the levers operating the selector shafts.
	57	Various tools.
	58	Alignment of the pulleys.
	59	Gear change control.
	60	Gear change control.
	61	Various tools.
FRONT AXLE .....	62	Sections.
	62 A	Section of the upper ball joints.
	63	Various tools.
	64	Various tools.
	65	Support for half-axle.
	66	Various tools.
	67	Assembly of the seals.
	68	Assembly of the driveshaft dust cover.
	69	Adjustment of the castor angle.
REAR AXLE .....	70	Section of hub.
	71	Arm pivot bearing.
	72	Method of securing the arm pivot bearing.
	73	Holding the arm in a vice.
	74	Extraction of the hub brake drum.
	75	Extracting the hub bearings.
	77	Adjustment of bearing clearances.

COMPONENT	No. of Illustration	DESCRIPTION
SUSPENSION .....	78	Hydraulic system.
	79	Front axle suspension.
	80	Anti-roll bar and height corrector control.
	81	Rear axle assembly.
	82	Rear suspension cylinder.
	83	Manual height control gear.
	84	High pressure pump.
	84 A	High pressure pump.
	85	Pressure control valve and pressure distribution block.
	86	Height corrector - suspension cylinder.
	87	Various tools.
	88	Various tools.
	89	Sealing plugs - tapered sleeves.
STEERING .....	90	Assembly.
	91	Fitting the steering wheel.
	92	Various tools.
	93	Various tools.
	94	Section of the relay.
	95	Adjusting the position of a relay.
	96	Various tools.
	97	Adjustment of the pinion.
BRAKES .....	98	Hydraulic system for brakes.
	99	Front brake unit.
	100	Front brake unit.
	101	Tools for brakes.
	102	Rear brake backplate.
	103	Removing and fitting the return springs.
	104	Grinding the rear brake drum.
	105	Riveting the brake-cam pins.
	106	Centring the brake shoes.
	107	Pedal gear.
	108	Master cylinders.
	109	Parking brake control (mechanical)
	110	Cable adjustment.
ADJUSTMENTS .....	111	Lifting points on the body.
	112	Checking the camber.
	113	Pre-adjustment of the front height.

## INDEX OF ILLUSTRATIONS

COMPONENT	No. of Illustration	DESCRIPTION
ELECTRICAL .....	114	DUCELLIER dynamo 7158-A.
	115	DUCELLIER dynamo 7158-A.
	116	PARIS-RHONE dynamo G11. R91.
	117	PARIS-RHONE dynamo G11. R91.
	118	DUCELLIER starter 6003-A.
	119	DUCELLIER starter 6003-A.
	120	PARIS-RHONE starter D11. B42.
	121	PARIS-RHONE starter D11. B42.
	121 A	Benada pinion.
	122	Assembly of the field coils and pole pieces.
	123	Wiring diagram.
	124	Wiring diagram.
HYDRAULIC .....	125	Hydraulic test bench.
	126	Hydraulic test bench.
	127	Test pipes and unions.
	128	High pressure pump. Inspection for leakage.
	129	Pressure control valve.
	130	Pressure distribution block. Inspection for leakage of the valve settings.
	131	Pressure distribution block. Inspection of the valve settings.
	132	Main accumulator - pressure test.
	133	Pressure control valve.
	134	Suspension cylinder. Inspection for leakage.
BODY .....	135	Lifting the car for towing. Points of anchorage.
	136	Lifting the car for towing (details).
	137	Support for towing.
	138	Support for towing (details).
	139	Support for towing (assembly).

OPERATIONS

ID 100-3

ID 111-1

ID 112-0

ID 112-1

ID 112-4

ID 120-4

ID 120-7

ID 231-1

ENGINE

ID 19

1

LONGITUDINAL SECTION

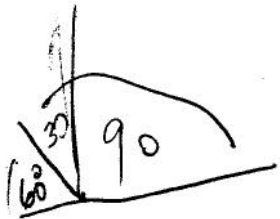
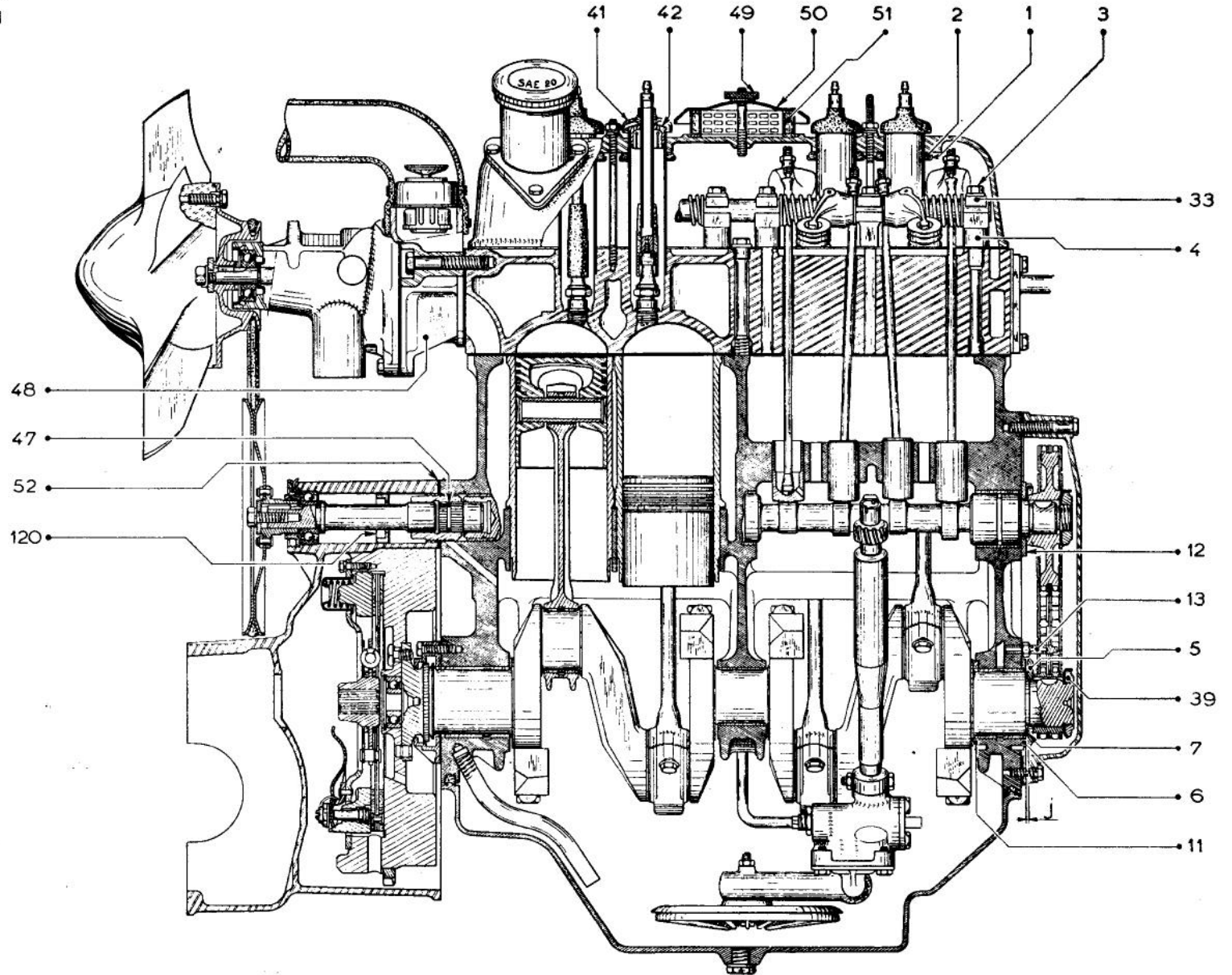

CROSS SECTION

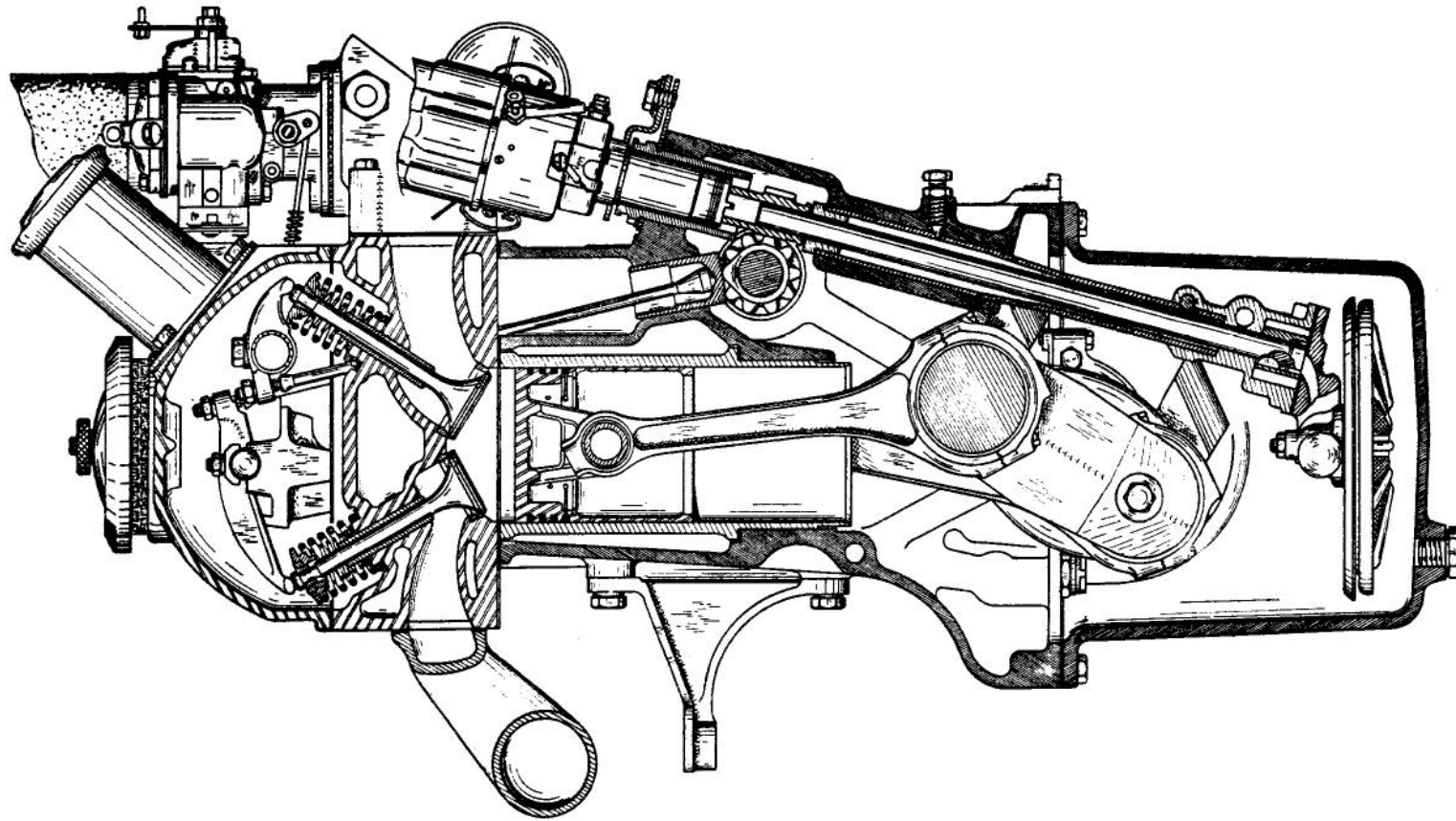

# ASSEMBLY OF THE VALVE ROCKERS

Fig. 1

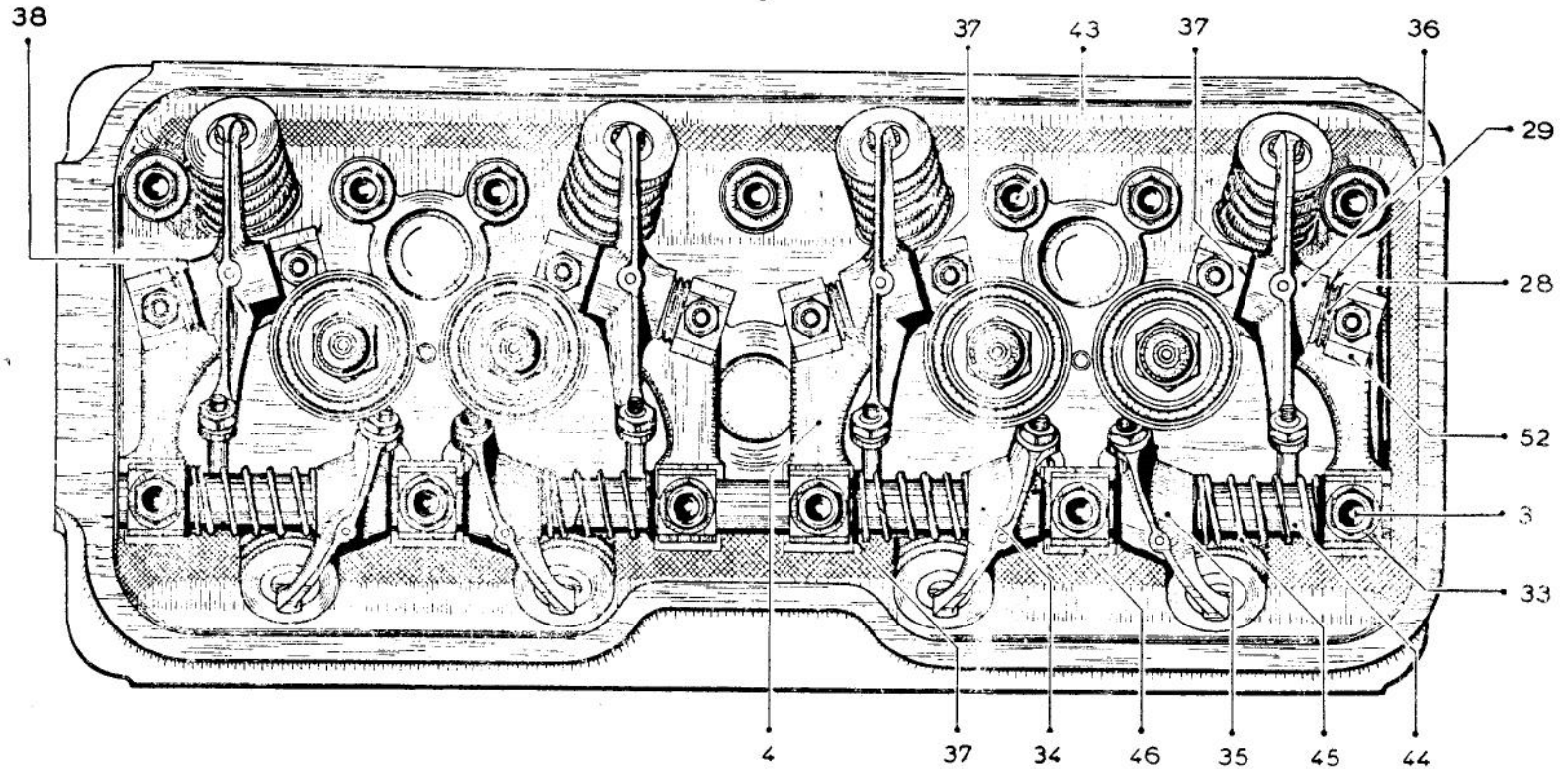

Fig. 2

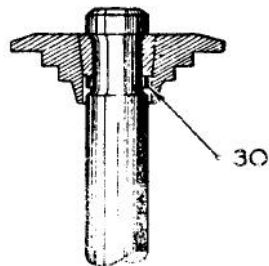

Fig. 3

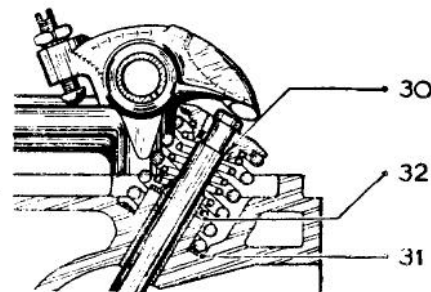
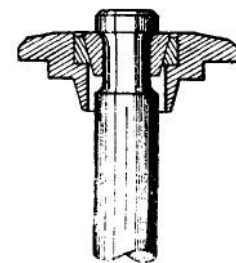

Fig. 4





VALVE SEATS

Fig. 1 EXHAUST VALVE SEAT

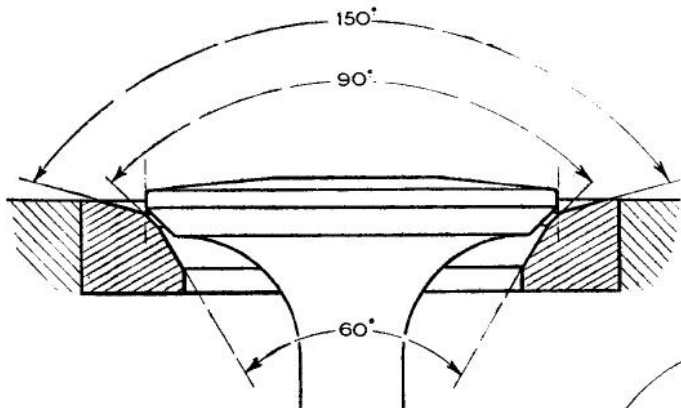

Fig. 2 INLET VALVE SEAT

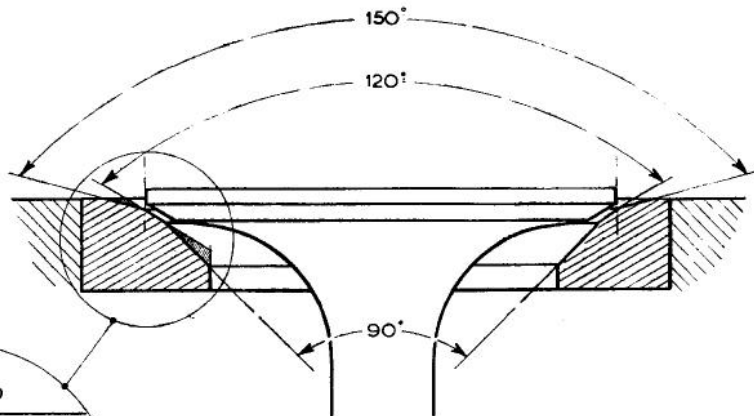

Fig. 3

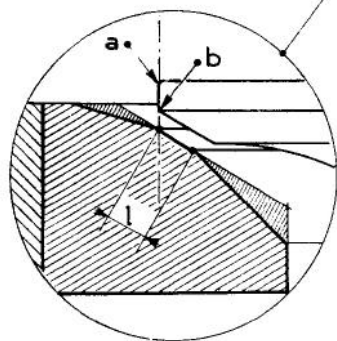

Fig. 6

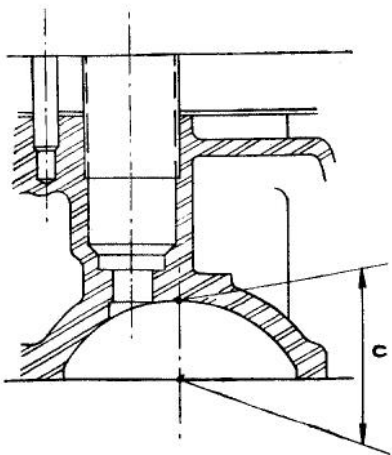

Fig. 4 VALVE GRINDING TOOL sold under No. 1615-T

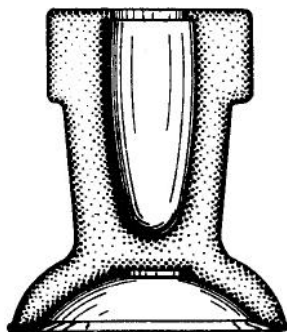
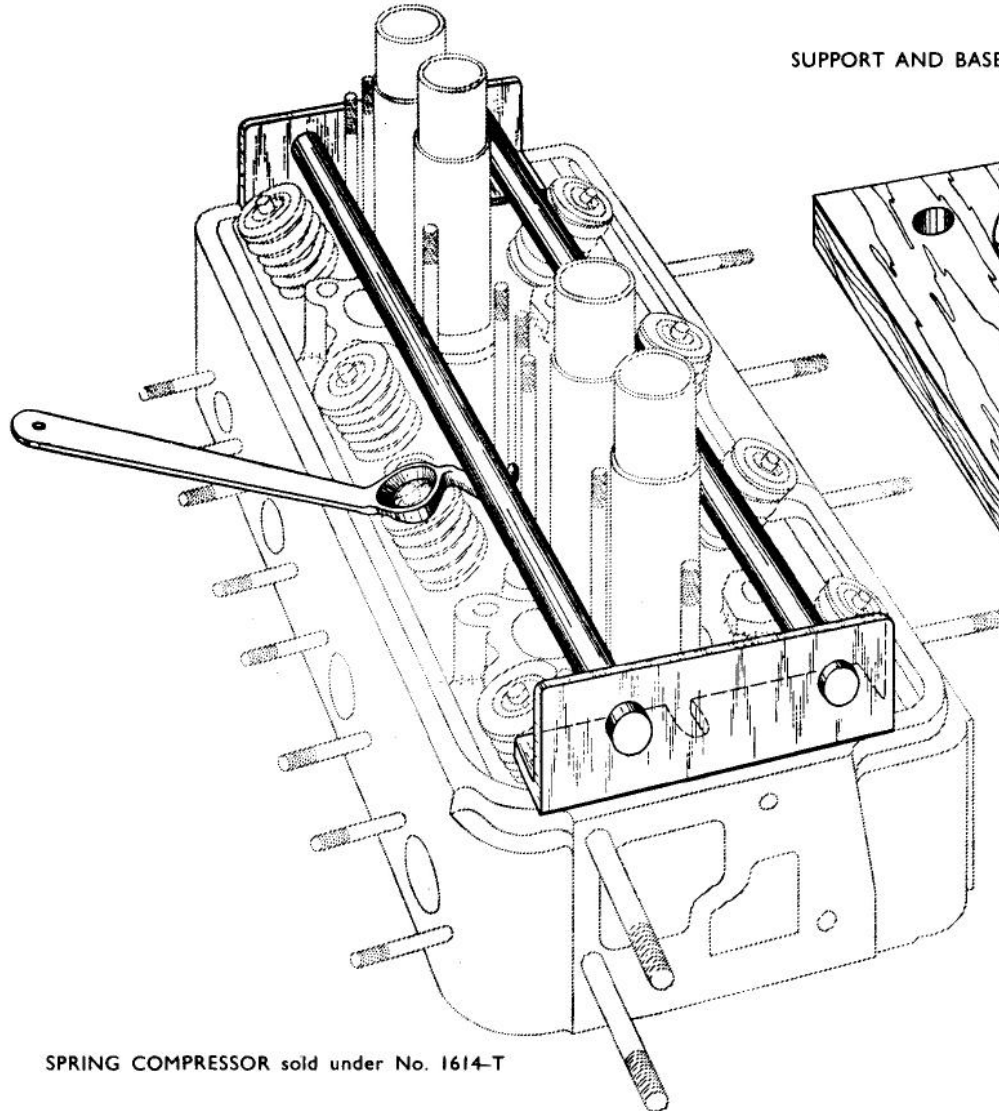

Fig. 5 TABLE OF GRINDING WHEELS

Seats to be Ground	Use of Wheel	Angle	Description of Grinding Wheel
INLET	Valve seat	120°	Single cone 44 dia. 1662-T
	For top clearance	150°	Biconical 44 dia. 1630-T
	For lower clearance	90°	
EXHAUST	Valve seat	90°	Biconical 40 dia. 1627-T
	For top clearance	150°	Single cone 40 dia. 1633-T
	For lower clearance	60°	

# FITTING THE VALVES

Fig 1



SPRING COMPRESSOR sold under No. 1614-T

Fig 2

SUPPORT AND BASE ASSEMBLY sold under No. 1616-T

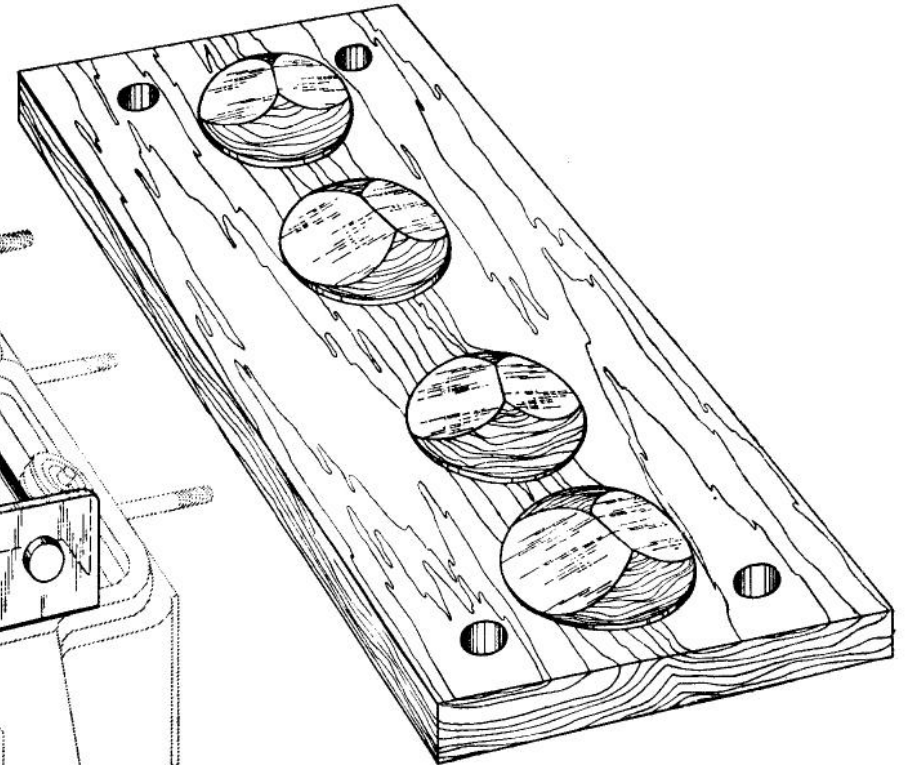
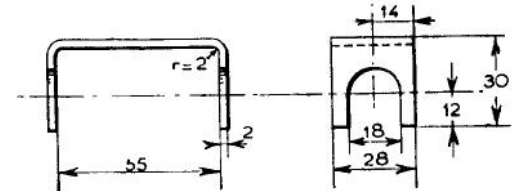

Fig. 3 RETAINER MR-4158-20, not sold



## CALIBRATION OF SPRINGS

## 1. CHECKING THE FREE LENGTH OF A SPRING

PLACE THE SPRING TO BE CHECKED (1) IN THE TWO GUIDES (2). BY HAND BRING THE SLIDE (3) INTO CONTACT WITH IT. THE INDEX MARK (4) IS NOW OPPOSITE THE FIGURE ON THE SCALE (5) (LENGTH) SHOWING THE FREE LENGTH OF THE SPRING (1).

## 2. CHECKING THE LENGTH UNDER LOAD

- A) PLACE THE CALIBRATED SPRING (6) (OR 12 AS THE CASE MAY BE) IN THE TWO HOLES (a) AND BRING THE SLIDE (8) INTO CONTACT WITH IT BY TURNING THE HAND WHEEL.
- B) BY THE HAND-WHEEL (9) BRING THE SPRING (1) TO BE CHECKED TO THE LENGTH UNDER LOAD SHOWN IN THE TEXT. READ THIS LENGTH OPPOSITE THE INDEX MARK (4) ON THE SCALE OF LENGTH (5).
- C) READ ON THE SCALE (10 (load in kg) OPPOSITE THE INDEX MARK 11 IF USING THE CALIBRATED SPRING (6))  
(14 (load in kg) OPPOSITE THE INDEX MARK 13 IF USING THE CALIBRATED SPRING (12))  
THE CORRESPONDING LOAD.

Fig. 1 — FIXTURE FOR CALIBRATING SPRINGS

sold under No.2420-T

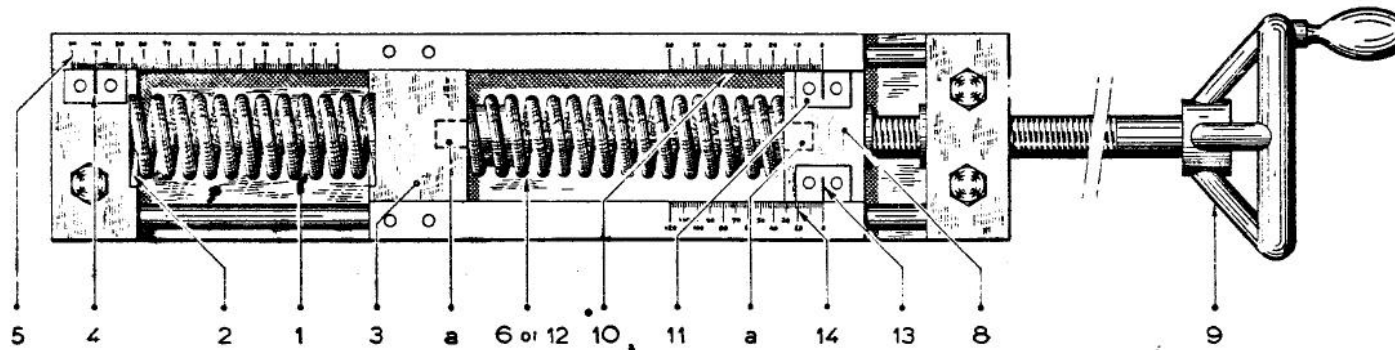
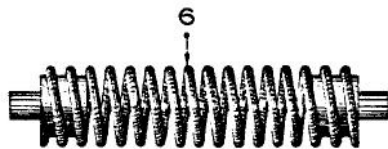

Fig. 2 — CALIBRATED SPRINGS



SPRING DEFLECTING 1 mm per KG

sold under No.2421-T

This spring is painted yellow

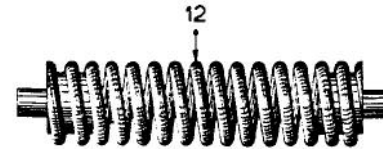

SPRING DEFLECTING 1 mm per 2 KG

sold under No.2422-T

This spring is painted red

## CYLINDER HEAD

Fig. 1 - SEQUENCE OF TIGHTENING SCREWS

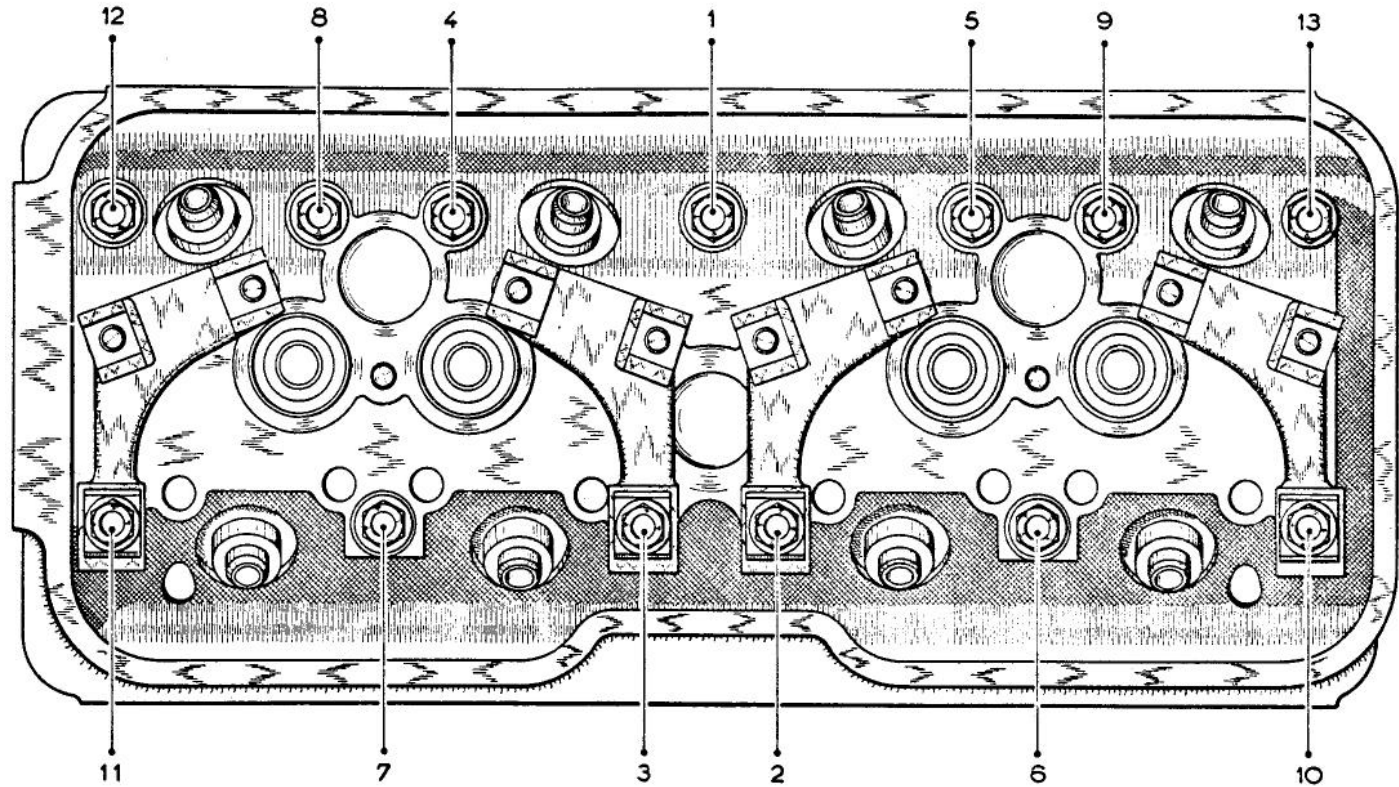

TENSION OF TIGHTENING (COLD). 1st TIGHTENING 21.75 FT./LBS. (3 M/KG). 2nd TIGHTENING 43.5 FT./LBS. (6 M/KG)

IT IS ADVISABLE TO TIGHTEN THE SCREWS IN THE ORDER INDICATED ABOVE. THE TENSION OF TIGHTENING IS OF THE GREATEST IMPORTANCE AND THE USE OF A TORSION SPANNER WITH A 12.7 SOCKET IS INDISPENSABLE (SOLD UNDER No.2465-T).

NSABLE

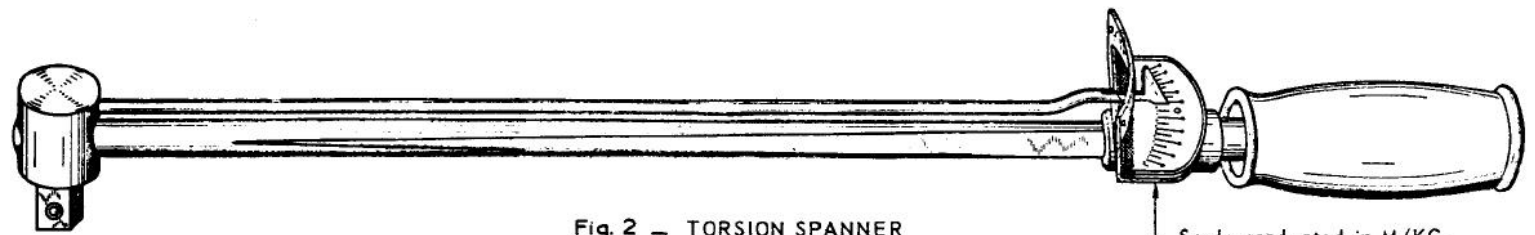

Fig. 2 - TORSION SPANNER

Scale graduated in M/KG.

sold under No.2471-T

## REPLACEMENT OF THE VALVE GUIDES

Fig 1 — EXTRACTING A GUIDE

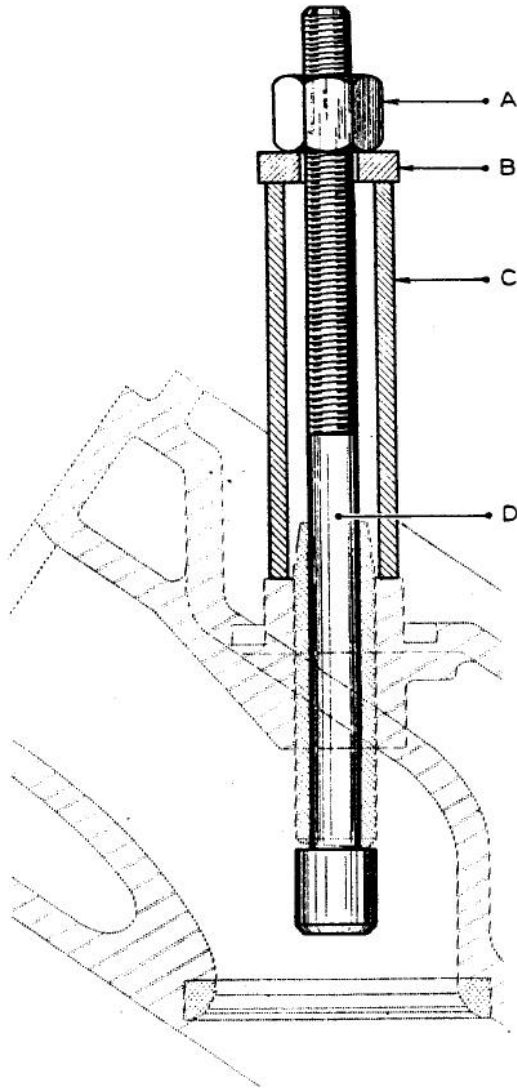

Fig 2 — FITTING AN INLET VALVE GUIDE

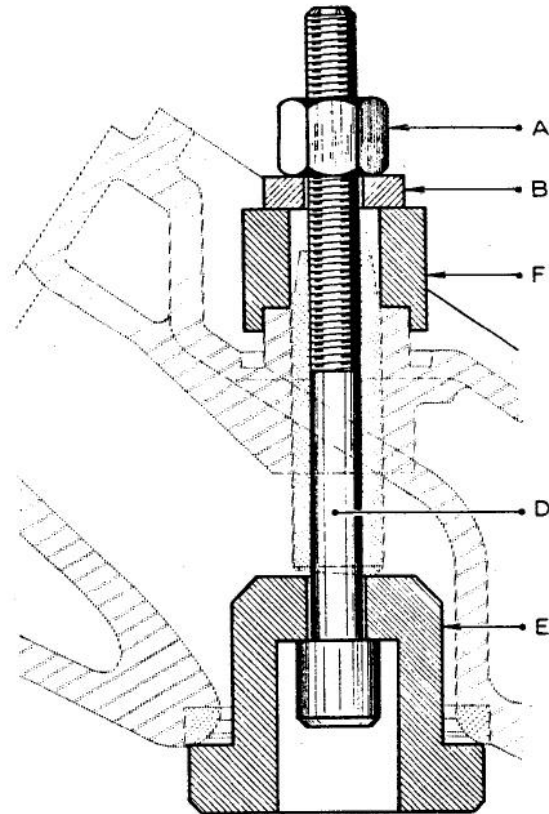
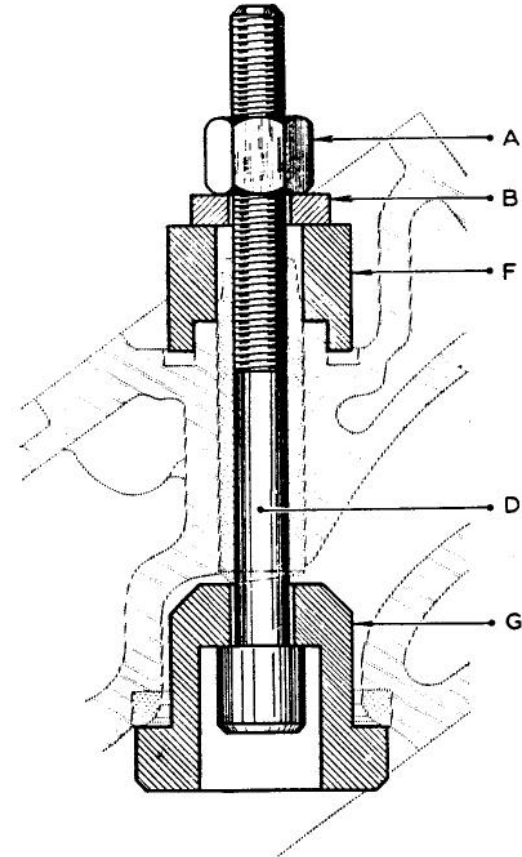

Fig 3 — FITTING AN EXHAUST VALVE GUIDE



TOOLS

sold under No.1644-T

## REPLACEMENT OF THE VALVE GUIDES

Fig. 1 — TOOLS GE  
sold under No.1644-T

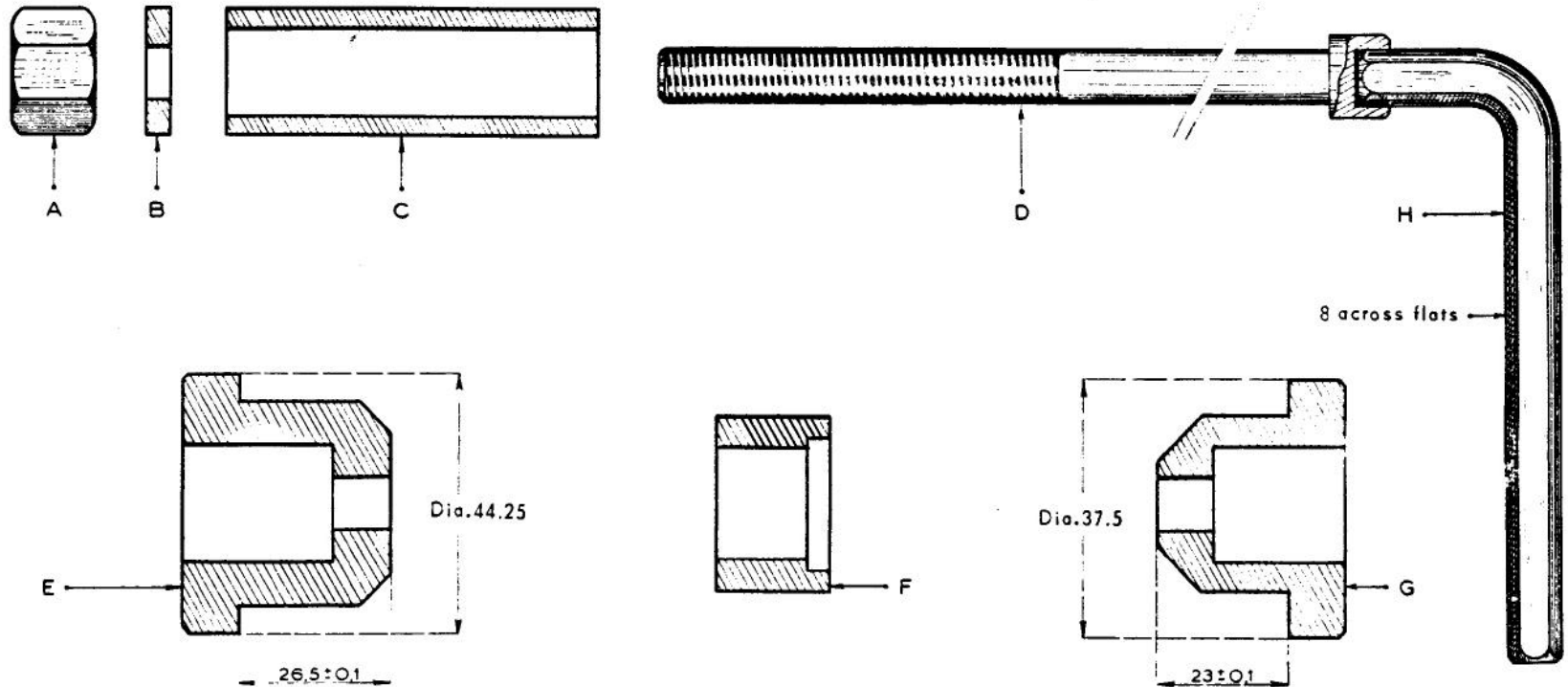

Fig. 2 — REAMER  
sold under No.1642-T



OIL PUMP

Fig 1

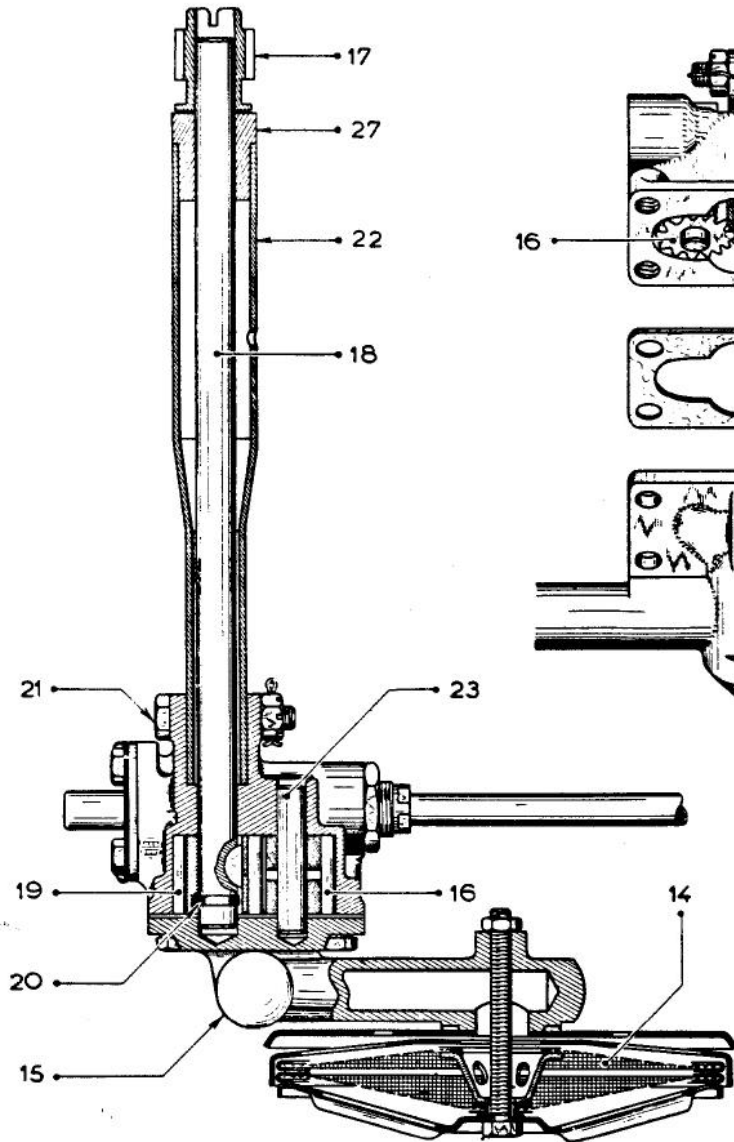

Fig 2

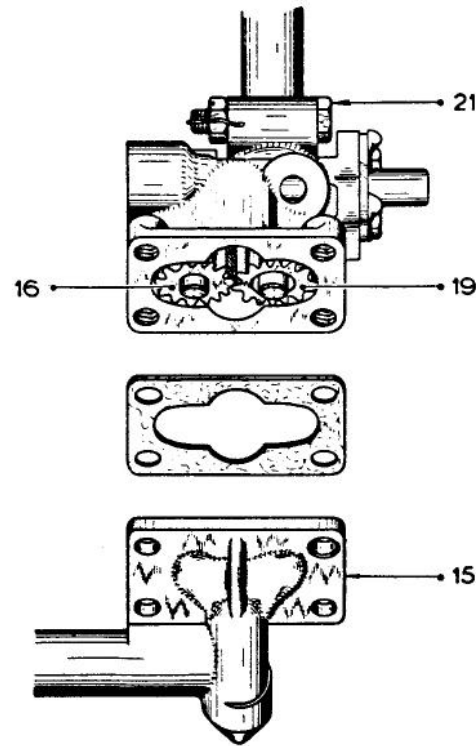

Fig 3

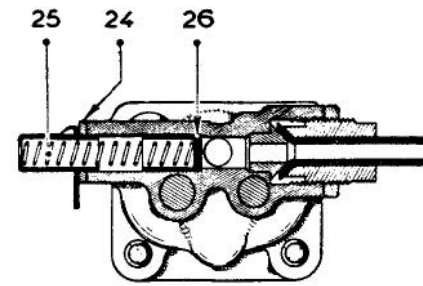
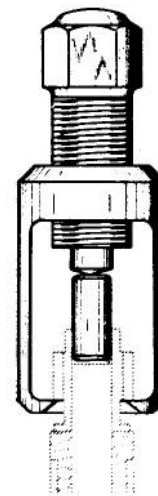

Fig 4 - EXTRACTOR  
sold under No.1964-T

PRESSURE PAD  
Ø=12, length 40



## ADJUSTMENT OF THE OIL PUMP

Fig. 1 — SIMPLIFIED ASSEMBLY MR.1811

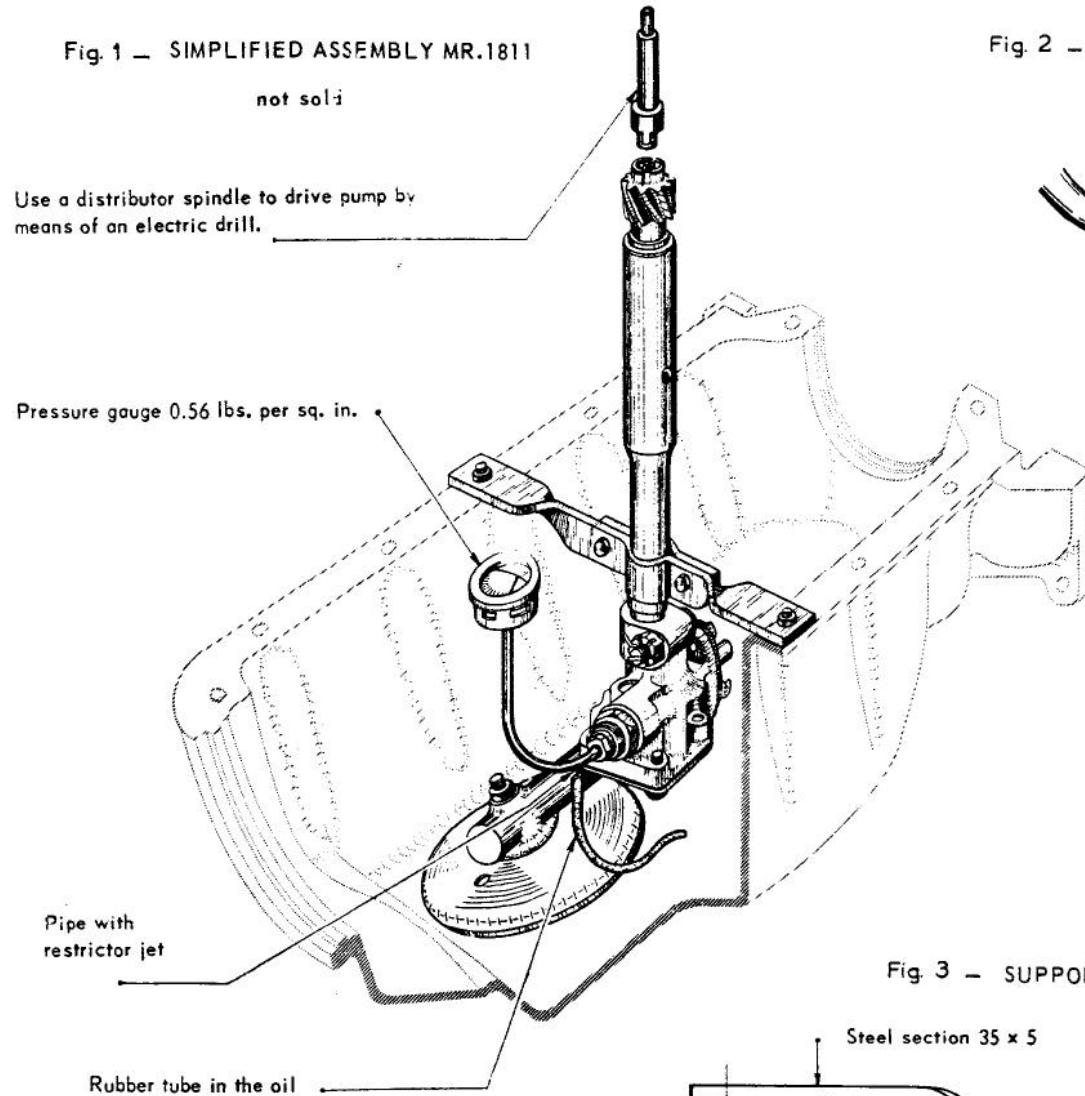
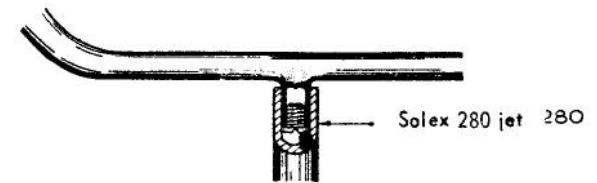
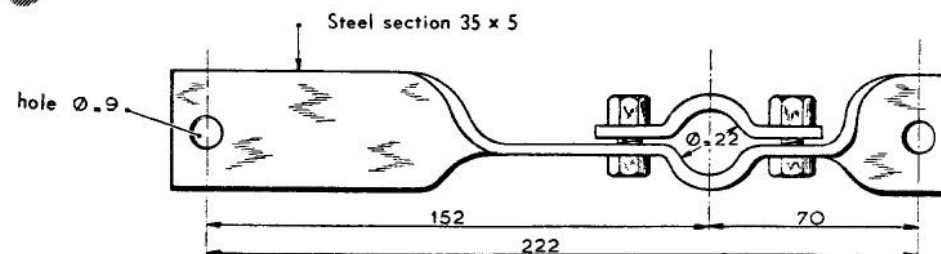

Fig. 2 — ASSEMBLY OF RESTRICTOR JET



WITH OIL OF SAE 20 VISCOSITY WARMED TO 60° - 50° C  
THE PRESSURE SHOULD BE 50 LBS. PER SQ. IN.  
(3.5 KG/CM<sup>2</sup>) AT 1000 R.P.M. IF THIS PRESSURE IS NOT  
OBTAINED CHANGE THE SPRING 25. SEE PLATE 10.

Fig. 3 — SUPPORT FOR PUMP





### FITTING CYLINDER BARREL JOINTS

Fig. 1

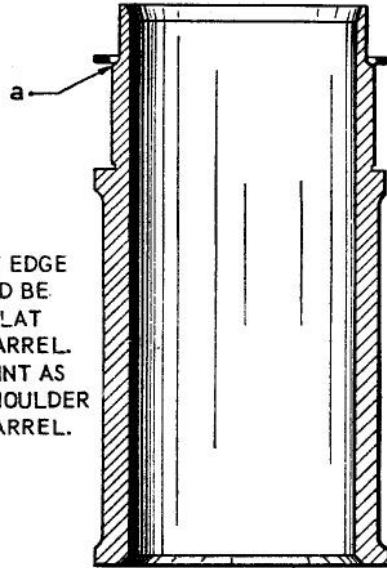

NOTE: THE STRAIGHT EDGE OF THE JOINT SHOULD BE PARALLEL TO THE FLAT ON THE CYLINDER BARREL. BY HAND FIT THE JOINT AS FAR AS THE FIRST SHOULDER ON THE CYLINDER BARREL.

Fig. 2

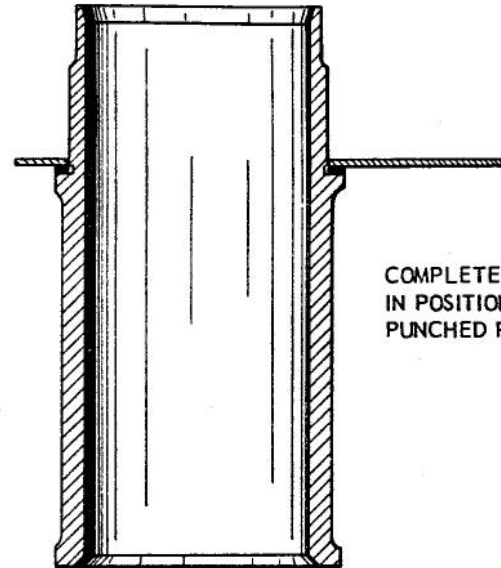

COMPLETE PUTTING THE JOINT IN POSITION BY MEANS OF THE PUNCHED PLATE MR.4134.

Fig. 3 - PUNCHED PLATE MR-4134

not sold

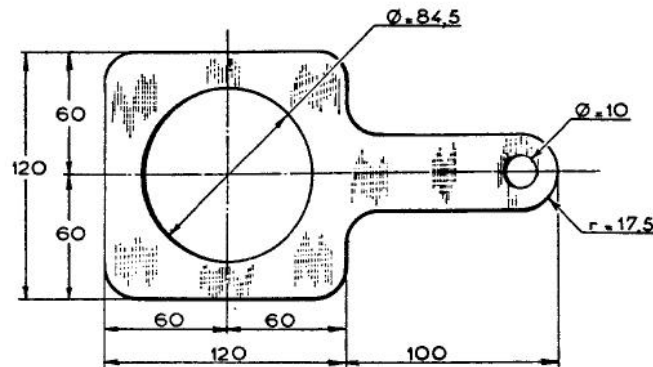



### ASSEMBLY OF THE OIL SEALS

Fig. 1

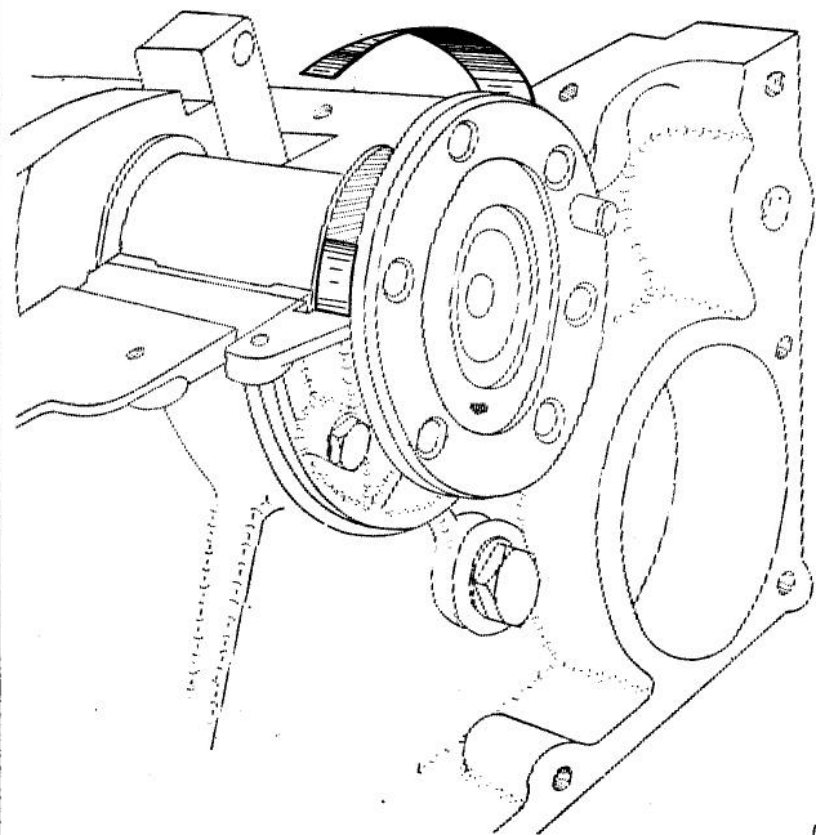

Fig. 2

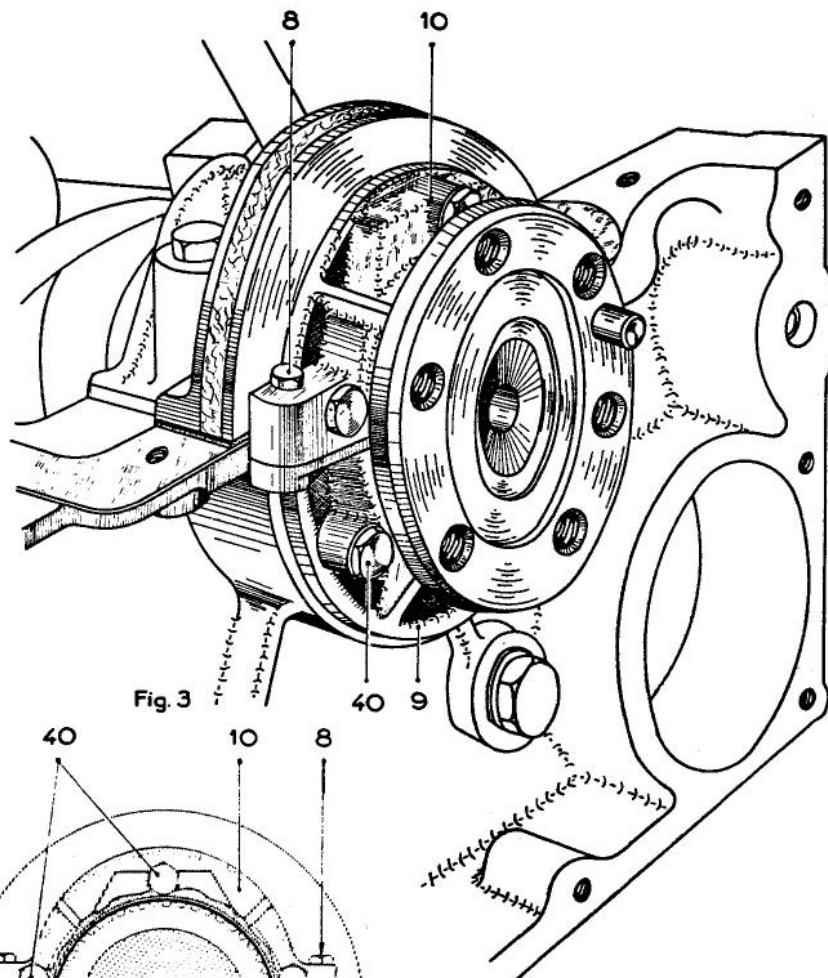
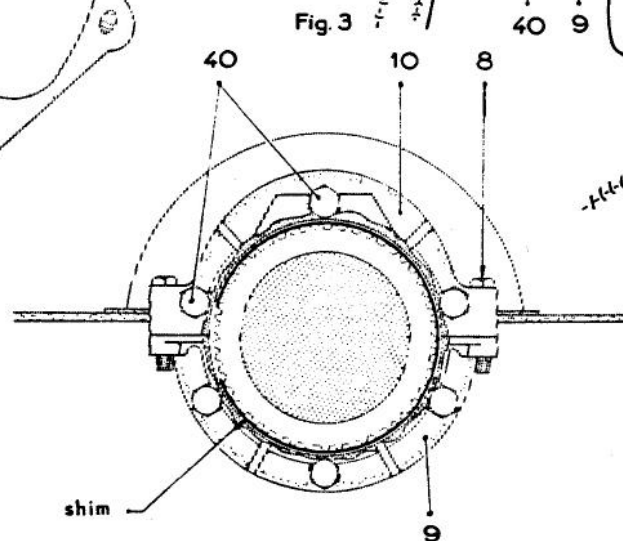

Fig. 3



THE ENDS OF THE SHIM MUST NOT  
EXTEND UP TO THE ASSEMBLY FACE  
OF THE HALF-SHELLS.

# SETTING THE TIMING WHEELS

Fig 1 - SPANNER  
sold under No.1667-T

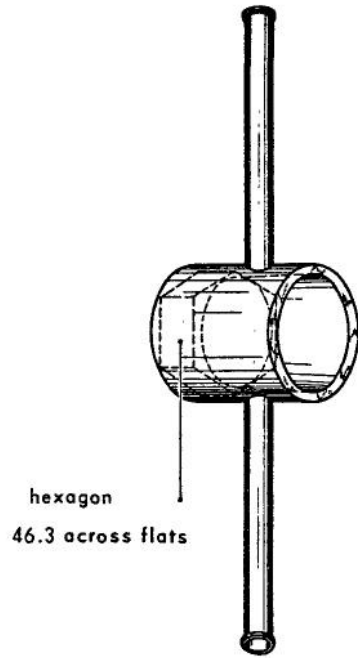

Fig. 2 - POSITION OF TIMING MARKS

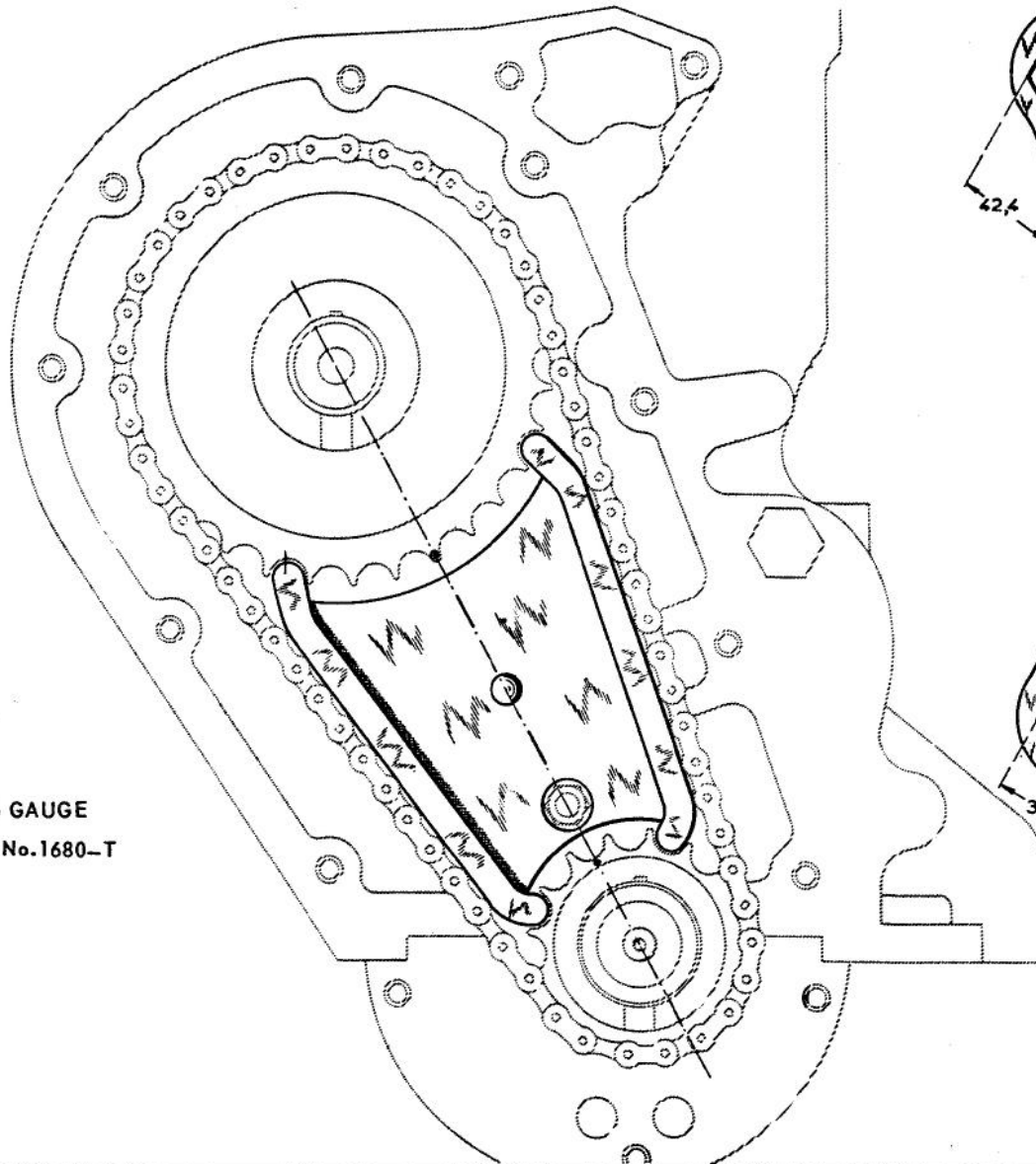
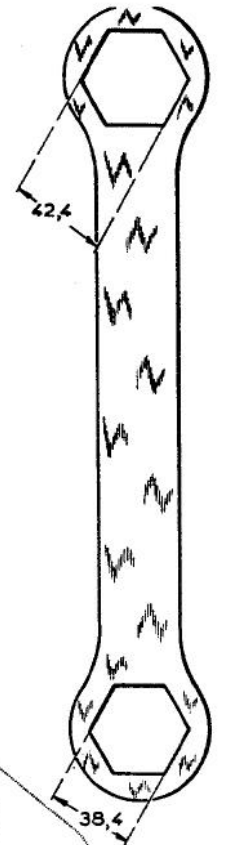

Fig. 3 - SPANNER  
sold under No.1731-T



SETTING GAUGE  
sold under No.1680-T

VARIOUS TOOLS

Fig. 1 - RETAINING CLIP MR-4158

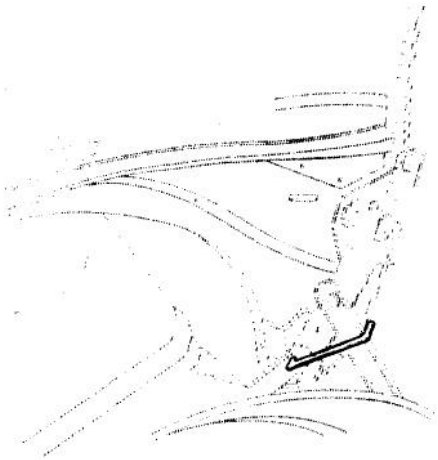
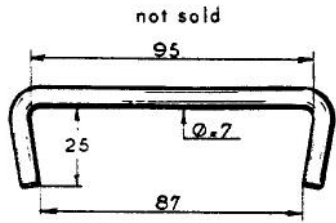

Fig. 2 - SPANNER MR-3462-70

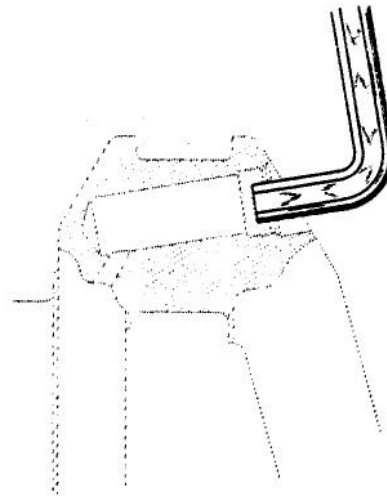
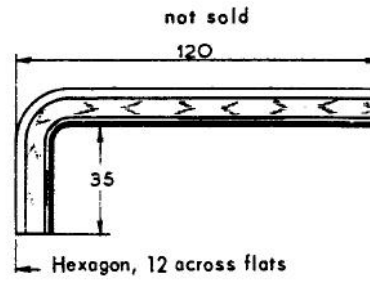

Fig. 3 - SPANNER  
sold under No.1645-T

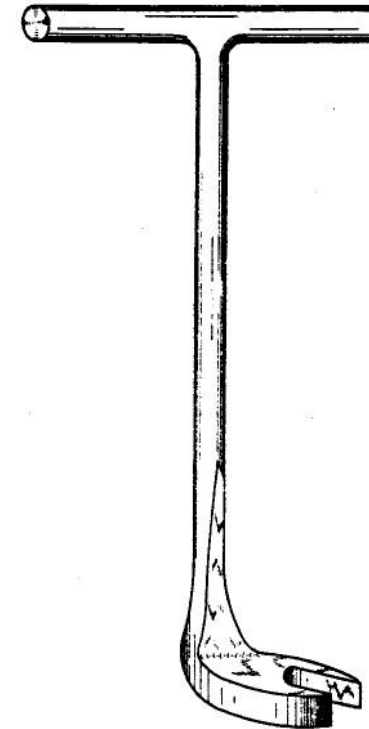

Fig. 4 - SPANNER

sold under No.1603-T

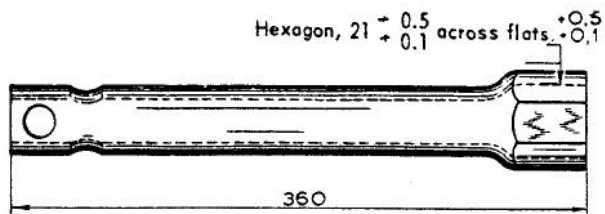

Fig. 5 - UNION SCREW MR-3705

not sold

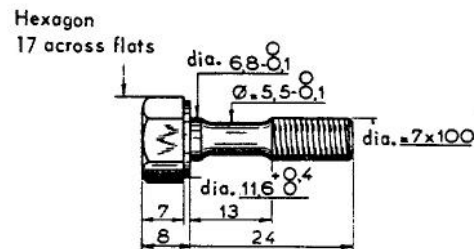

Fig. 6 - SOCKET

sold under No.1624-T



VARIOUS TOOLS

Fig. 1 - EXTRACTOR  
sold under No.1608-T

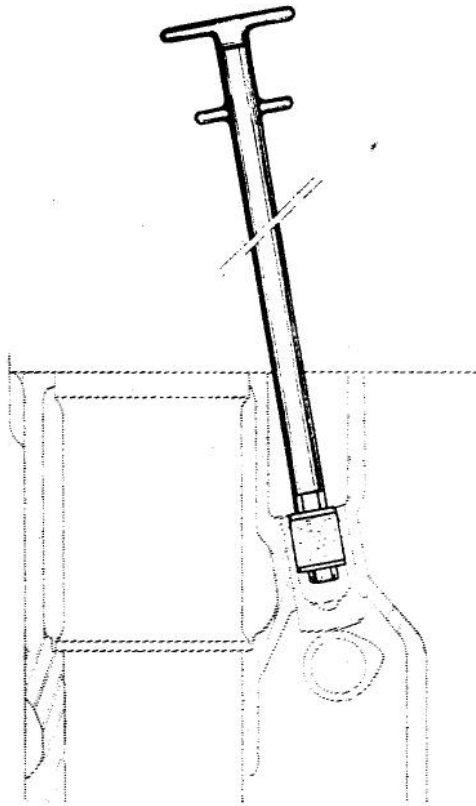

Fig. 3 - EXTRACTOR MR-3404-20  
not sold

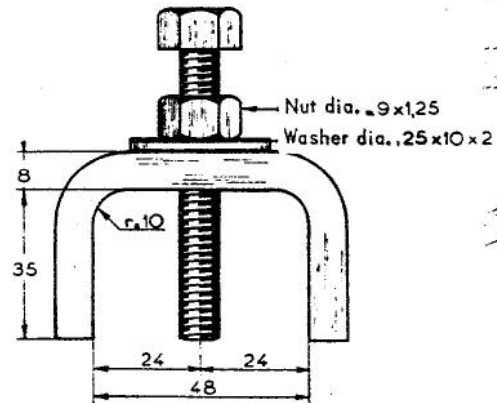
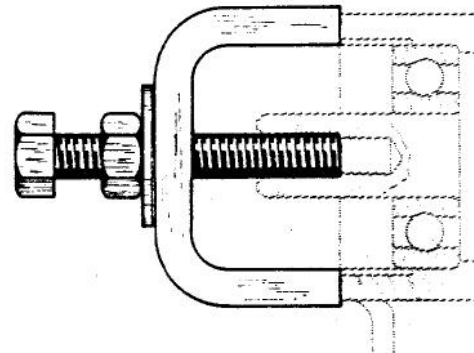

Fig. 4 - METHOD OF USING THE RING  
MR-4244

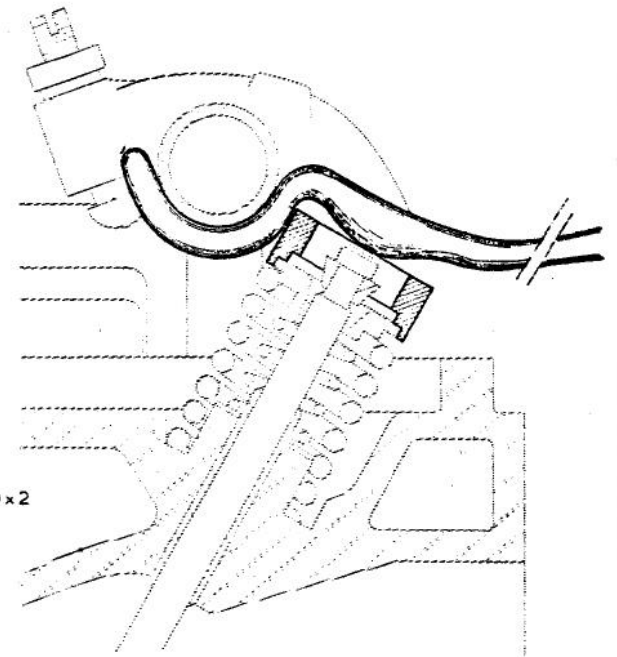

Fig. 2 - LIGAREX PLIERS  
sold under No.2483-T

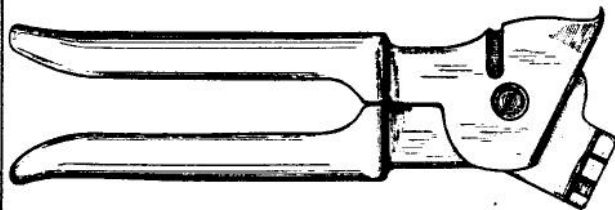
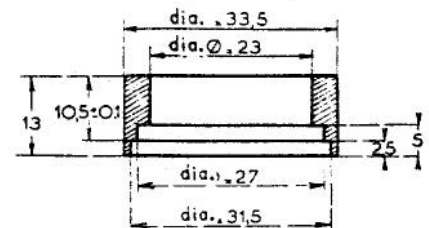
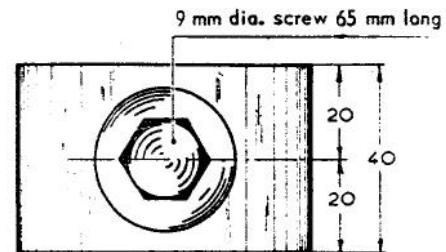

Fig. 5 - RING MR-4244  
not sold



## STANDS FOR DISMANTLED ENGINE

Fig 1 - STAND MR.3053-170

not sold

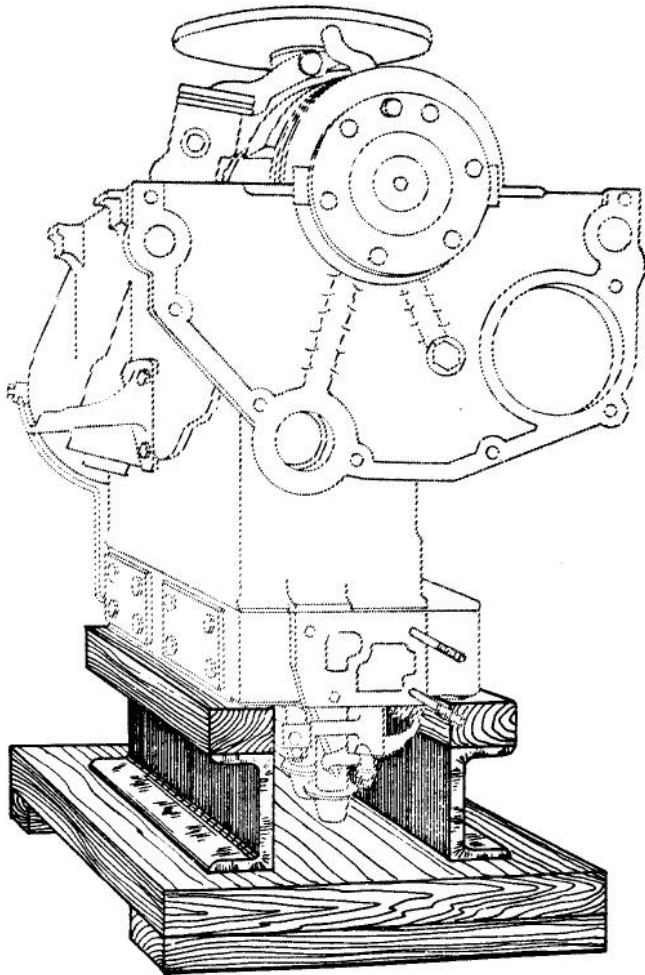
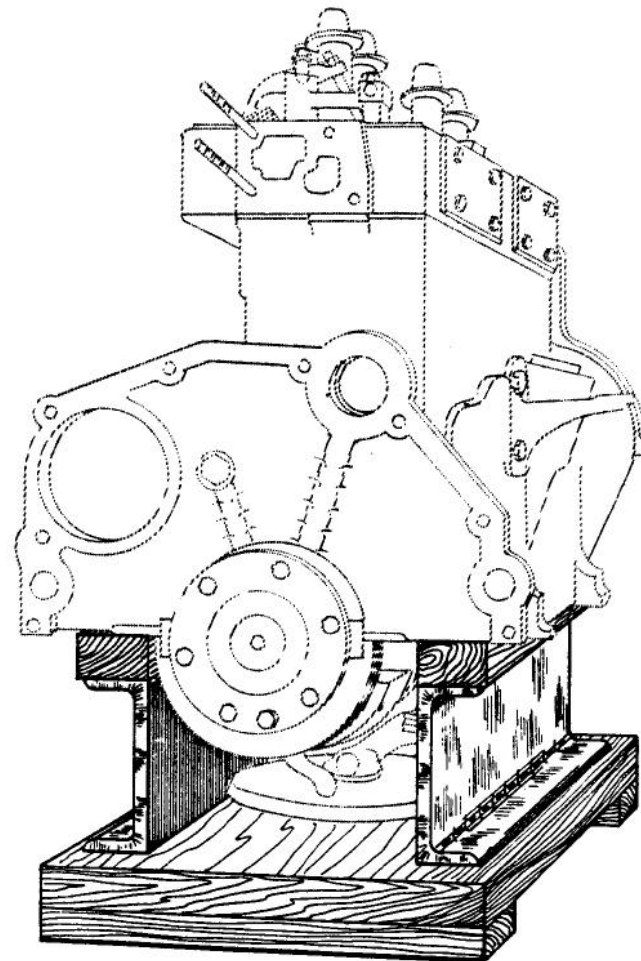

Fig 2 - STAND MR.3053-160 -160

not sold



FOR CONSTRUCTIONAL DIMENSIONS APPLY TO THE SERVICE DEPARTMENT

## STAND FOR DISMANTLED ENGINE GEARBOX ASSEMBLY

THE TRUCK PERMITS  
DISENGAGEMENT OF GEARBOX  
AFTER UNCOUPLING FROM  
THE ENGINE.

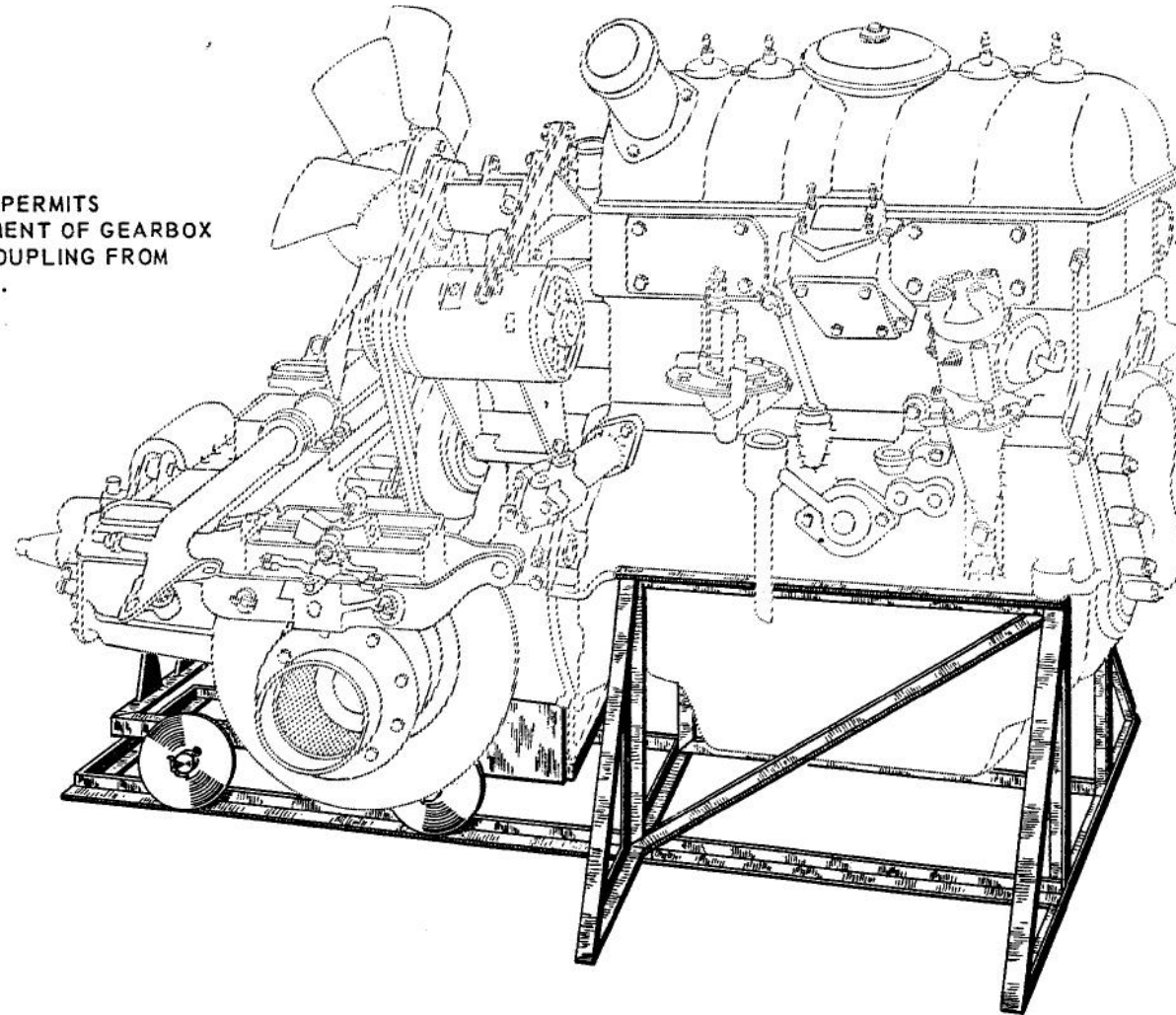

STAND AND TRUCK  
sold under No.2497-T



# ADJUSTMENT OF THE POSITION OF THE HIGH PRESSURE PUMP

Fig. 1 — SETTING THE DIAL GAUGER

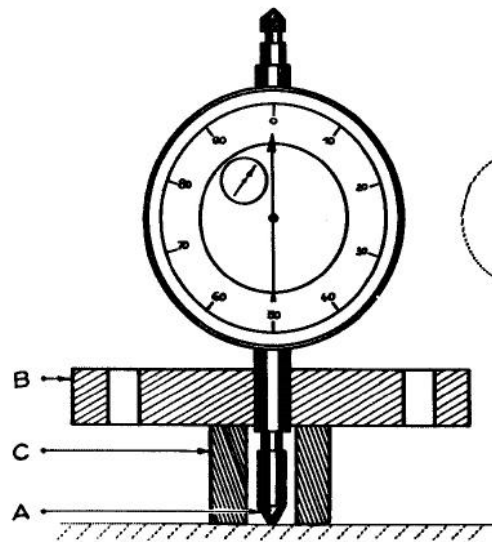

**TOOL**  
sold under No.1693-T

Fig. 2 — TAKING THE MEASUREMENT  
ON THE CYLINDER BLOCK

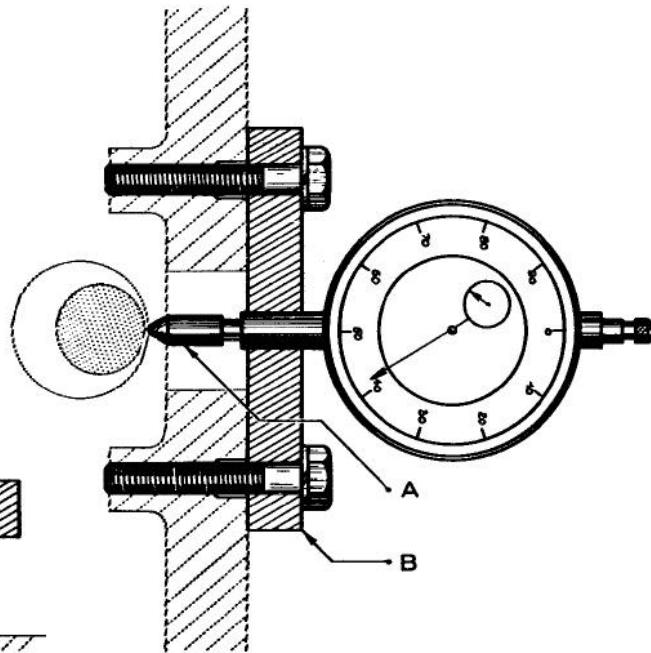

**DIAL GAUGE**  
sold under No.2437-T

Fig. 3 — FITTING THE PUMP ON THE  
CYLINDER BLOCK

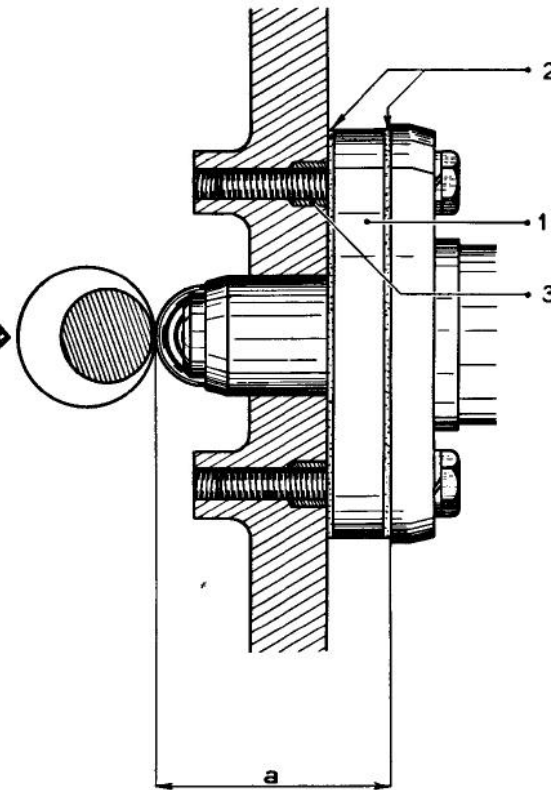

### CHECKING THE DISTANCE BETWEEN SUPPORT AND CROSSMEMBER

ADJUSTING FIXTURE

sold under No.1698-T

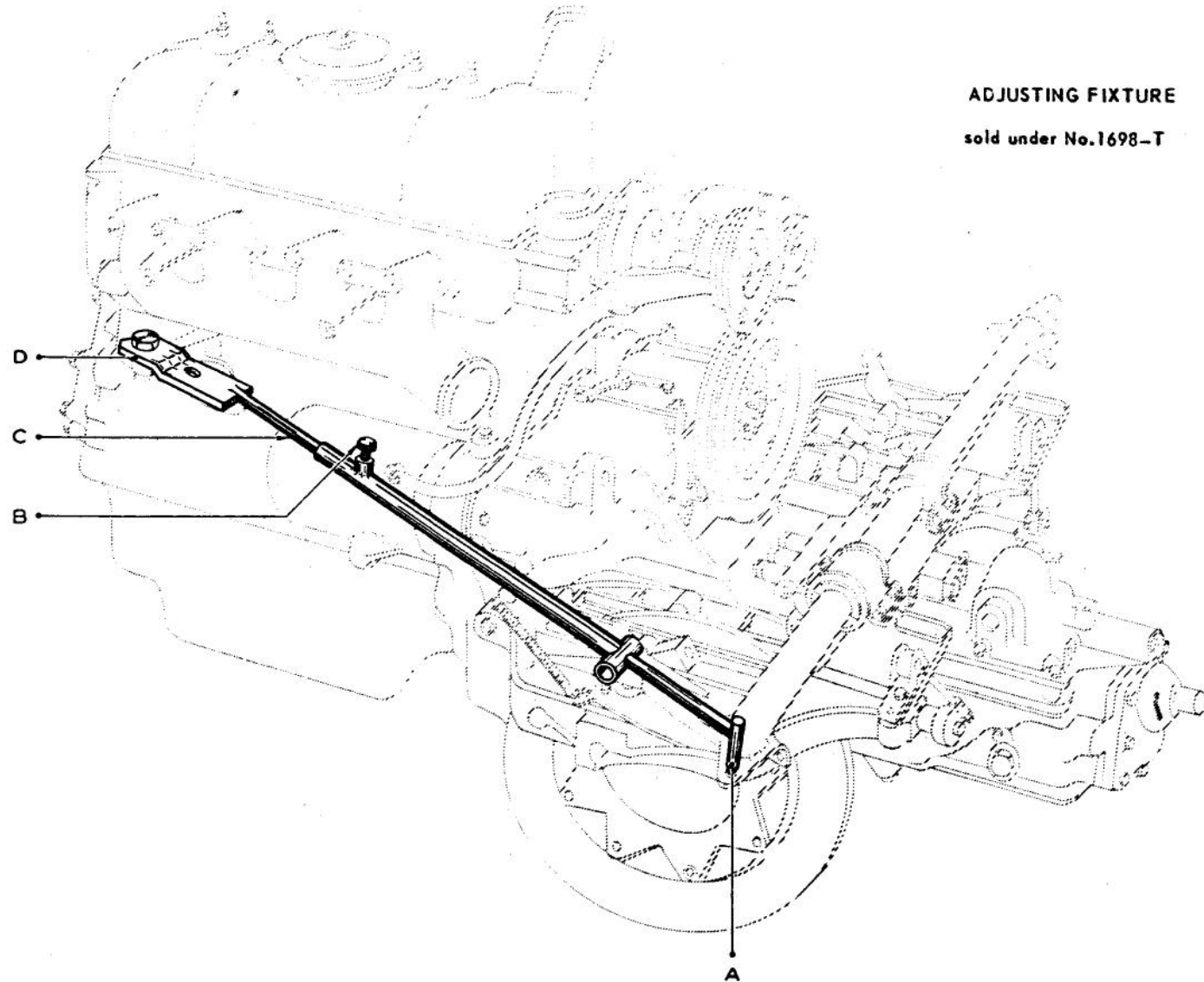

# ADJUSTING THE LONGITUDINAL POSITION OF REAR ENGINE SUPPORTS

ADJUSTING FIXTURE  
sold under No.1698-T

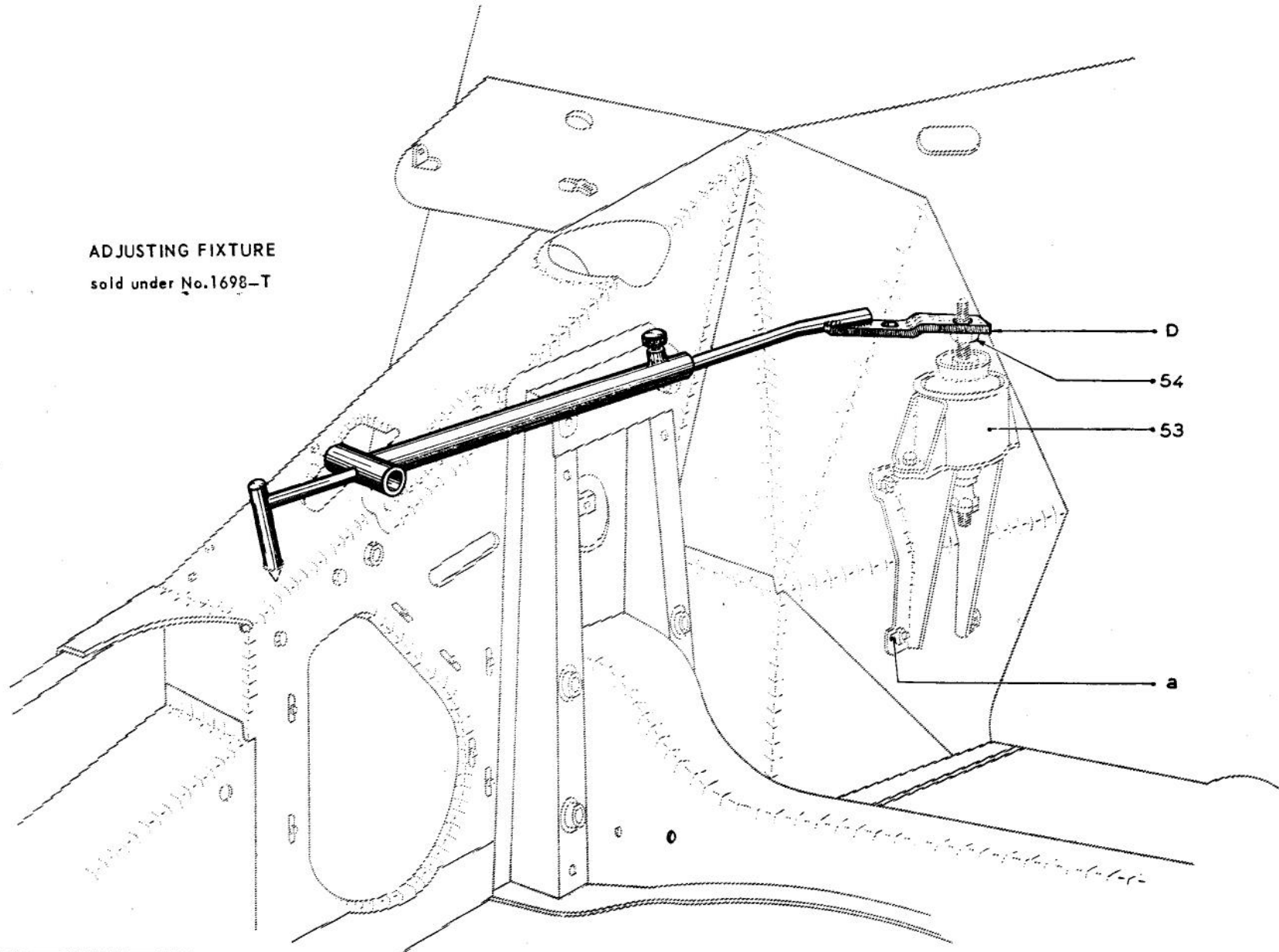

# ADJUSTING THE HEIGHT OF THE REAR ENGINE SUPPORTS

ADJUSTING FIXTURE  
sold under No.1698-T

POSITION OF THE GAUGE  
ON THE NUT 54

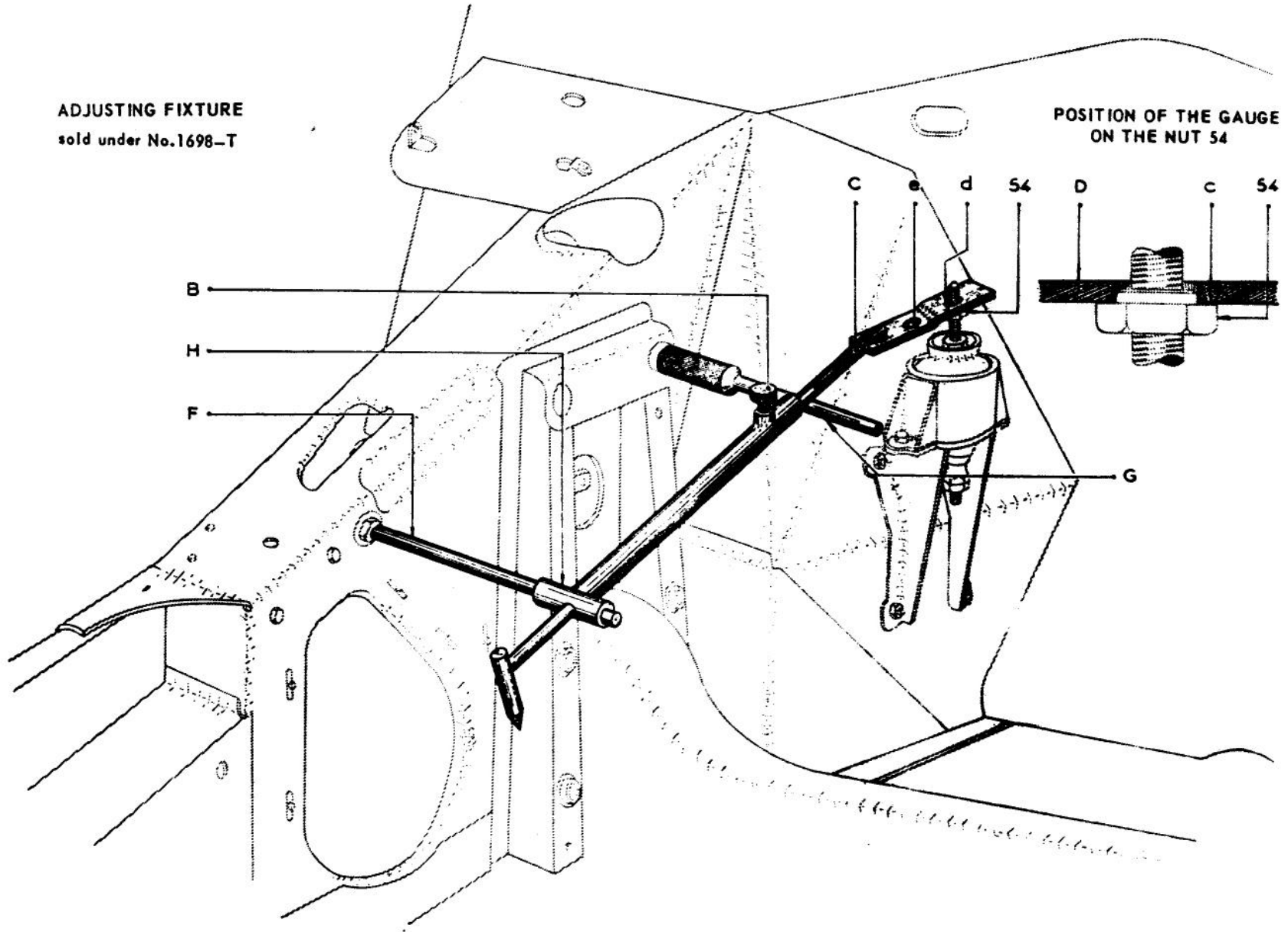

# ADJUSTING THE CENTRES OF THE REAR ENGINE SUPPORTS

ADJUSTING FIXTURE  
sold under No. 1698-T

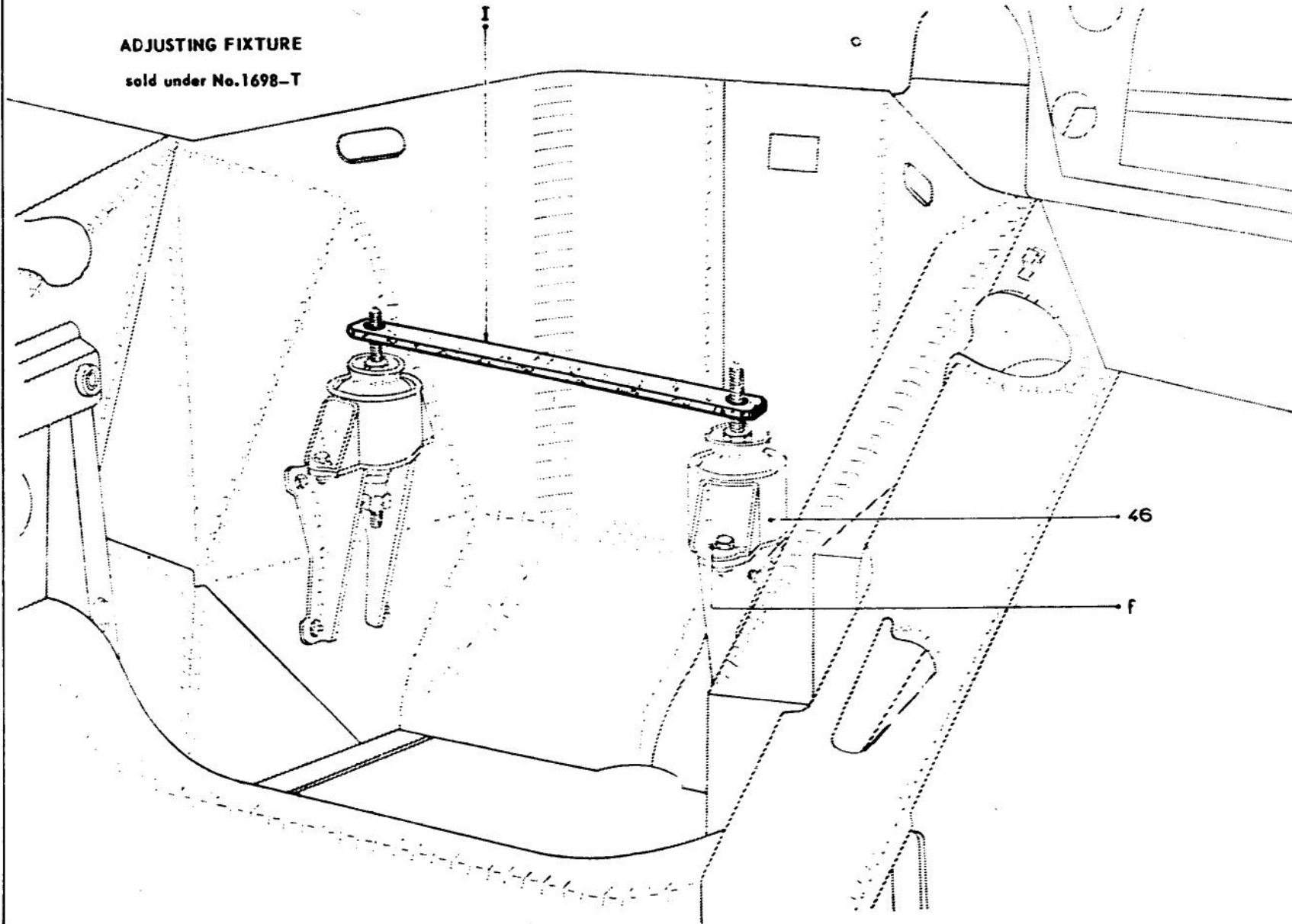

### SPANNERS FOR ADJUSTMENT OF REAR ENGINE SUPPORTS

Fig 1

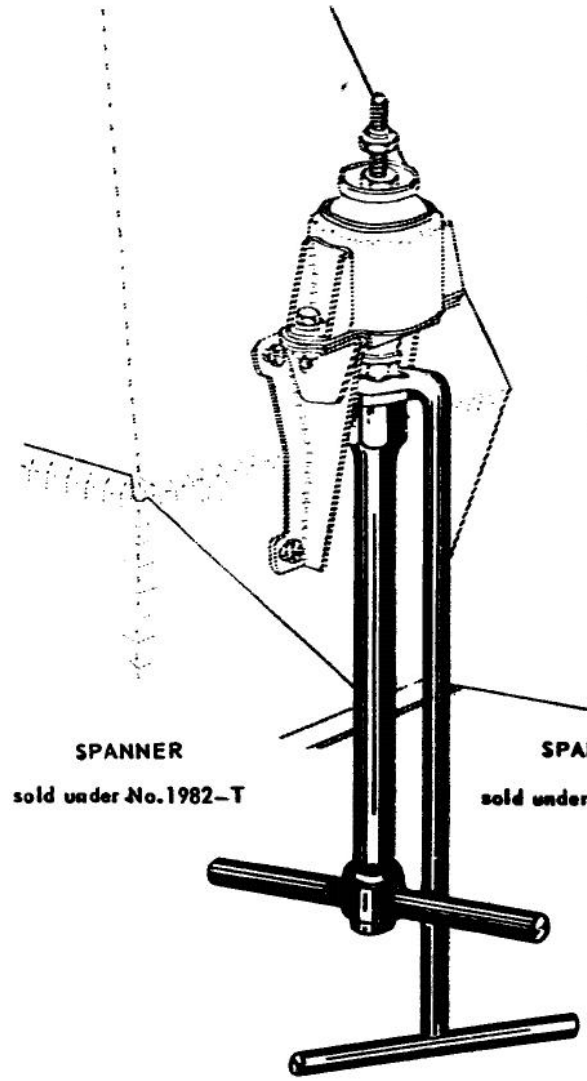

SPANNER  
sold under No.1982-T

Fig 2

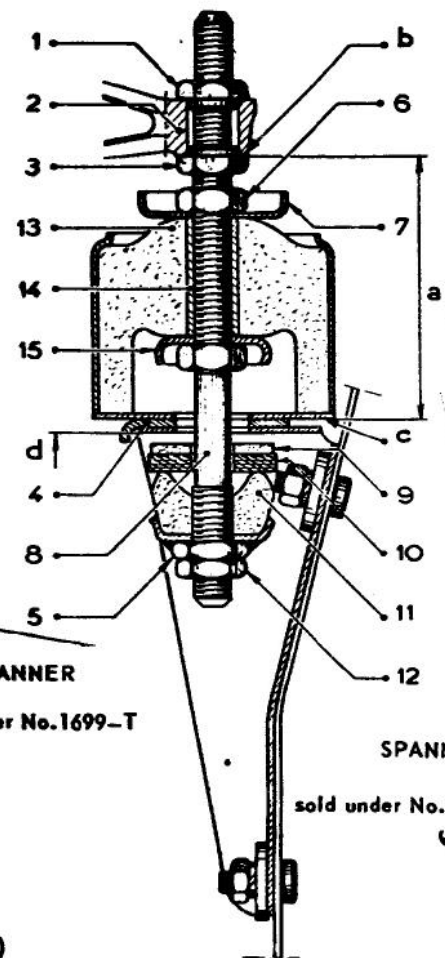

SPANNER  
sold under No.1699-T

Fig 3

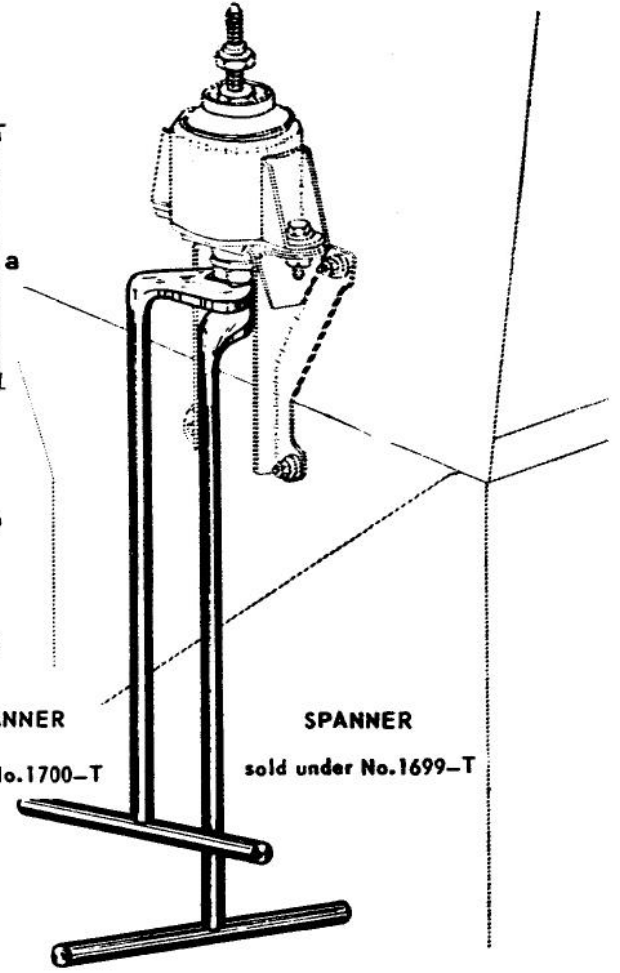

SPANNER  
sold under No.1700-T

SPANNER  
sold under No.1699-T

SOLEX 34 PBIC

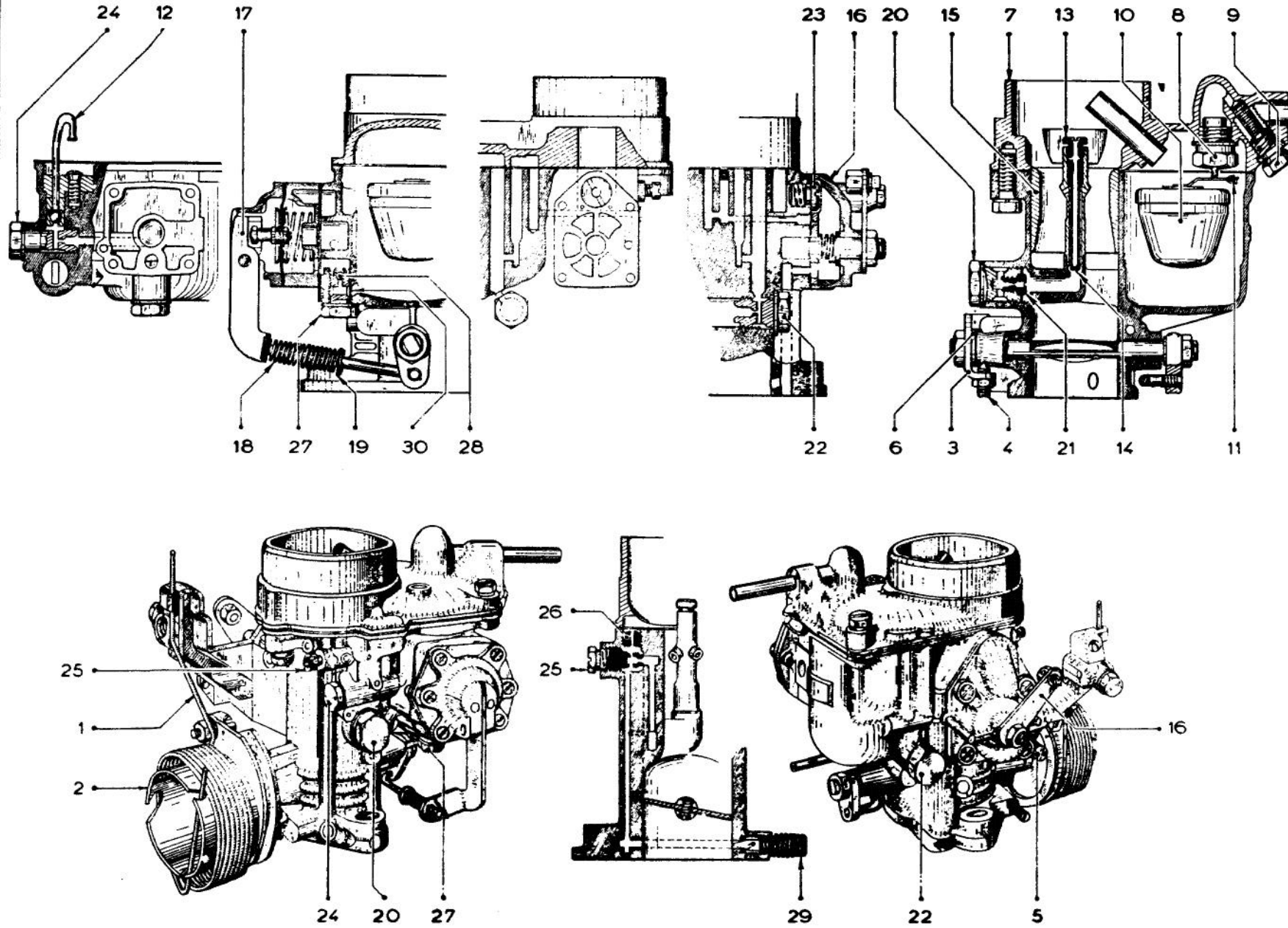

# ACCELERATOR CONTROL

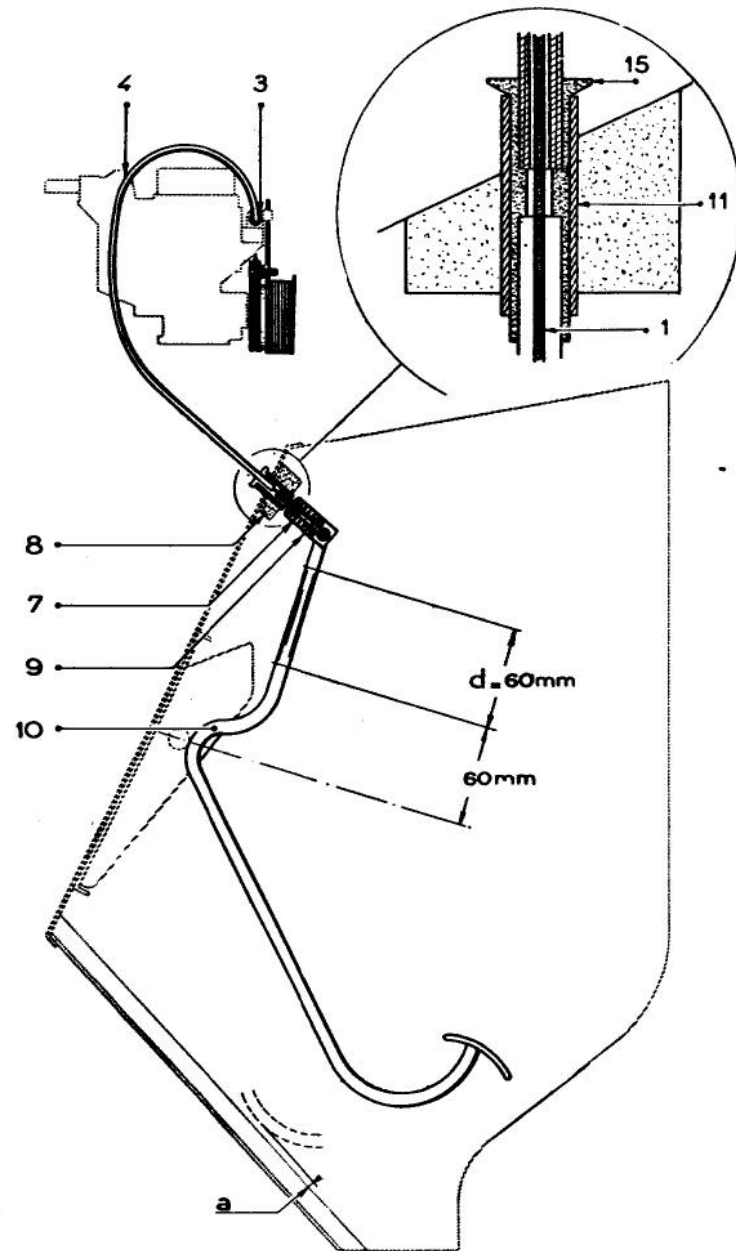
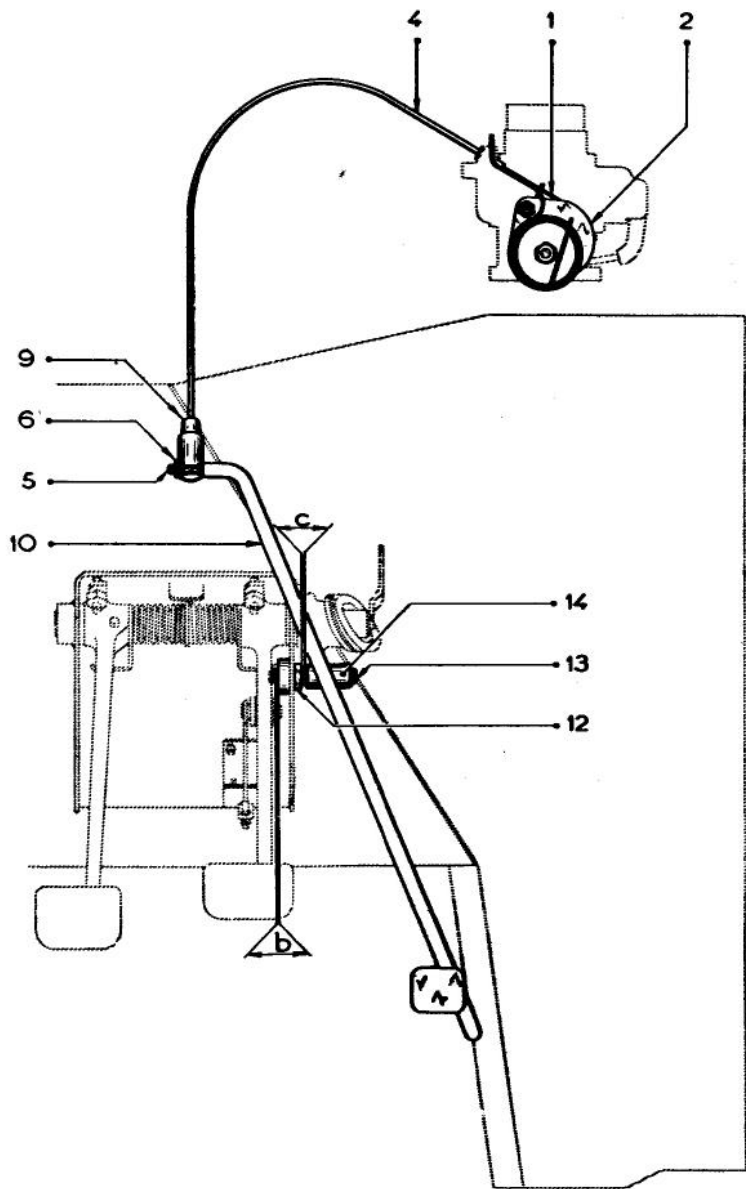



"NIOFILTRE" AIR FILTER

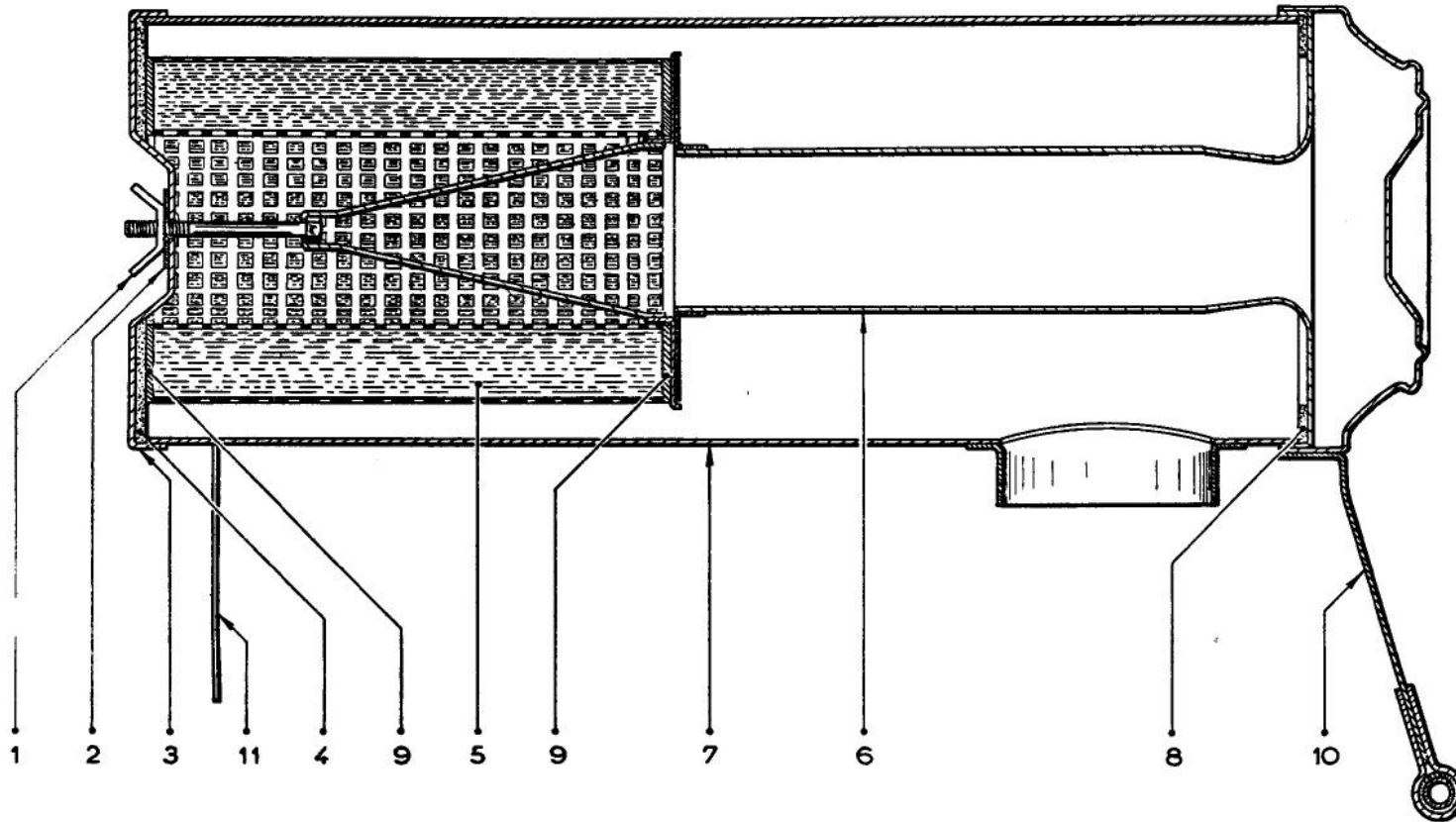

"VOKES" AIR FILTER

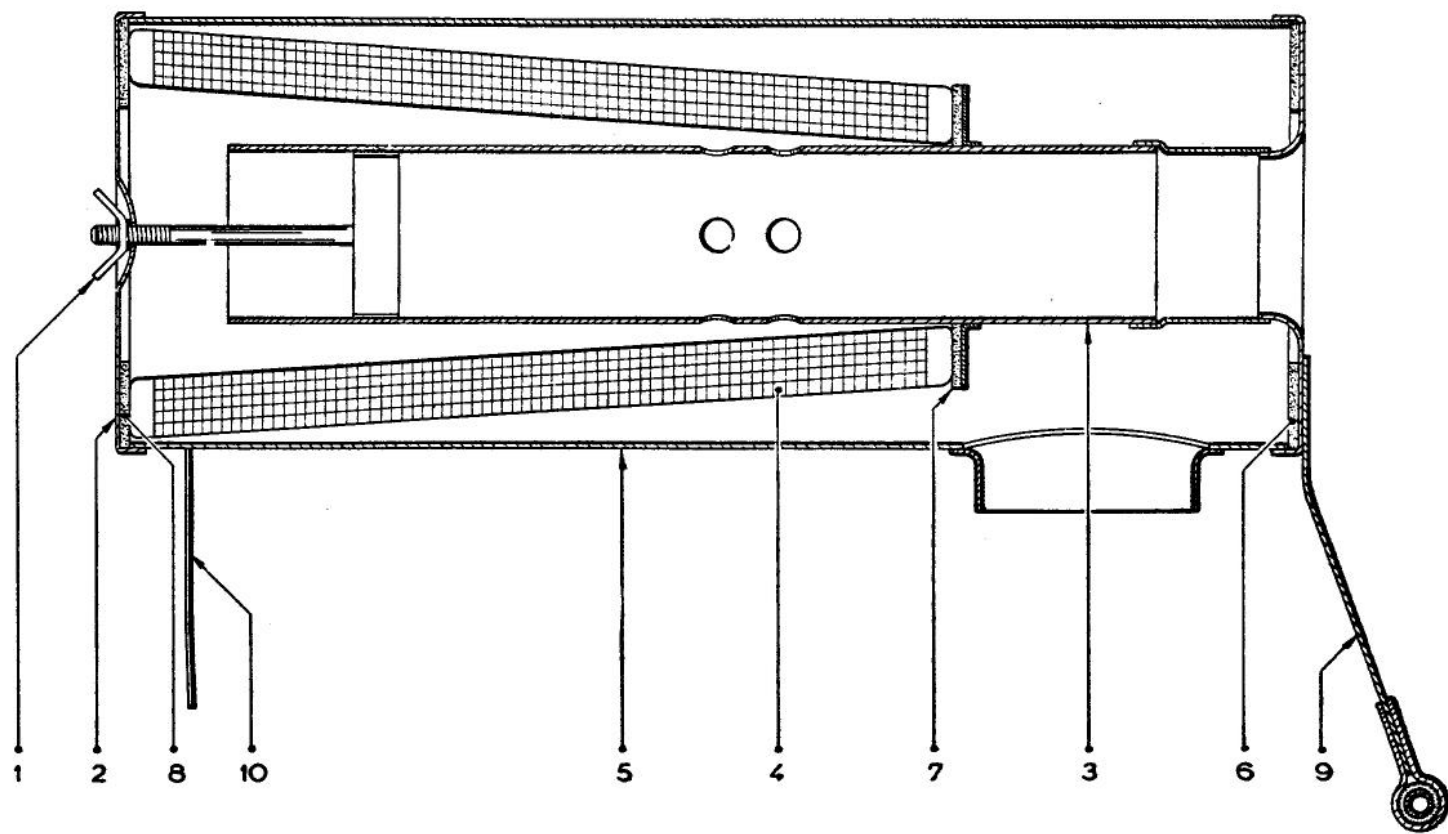

SECTION OF GUIOT PUMP

Fig 1

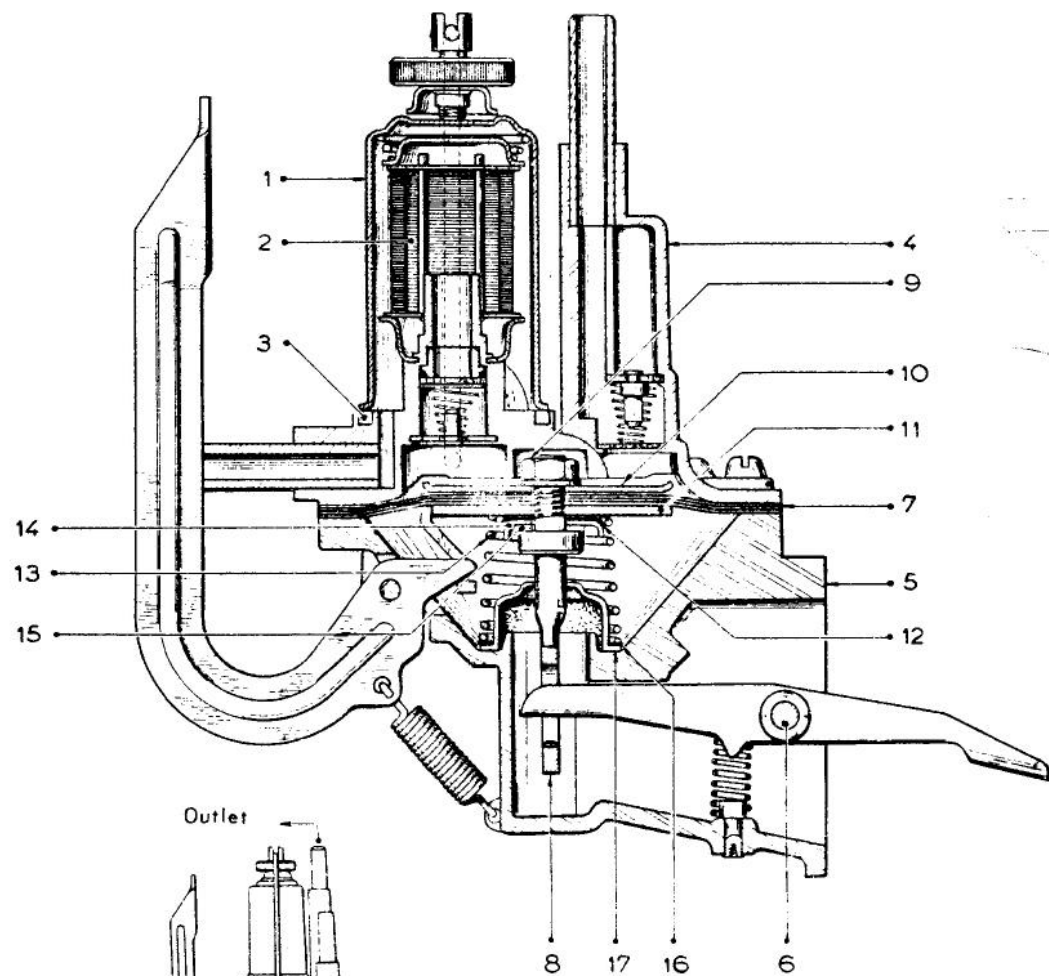

Fig. 3

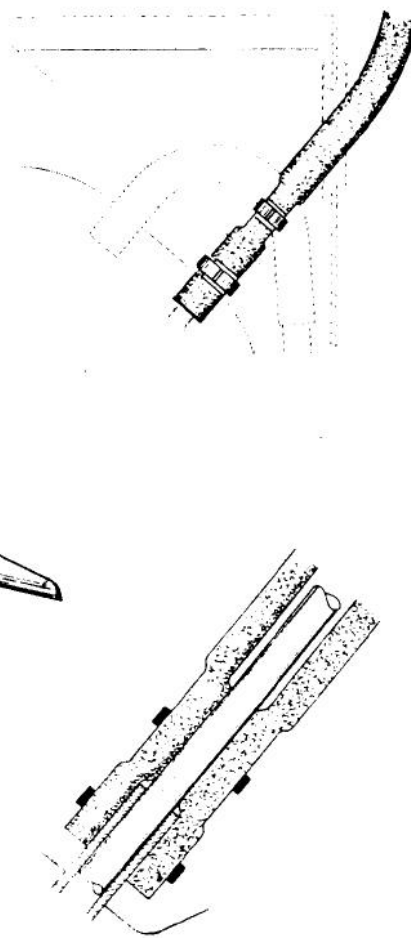
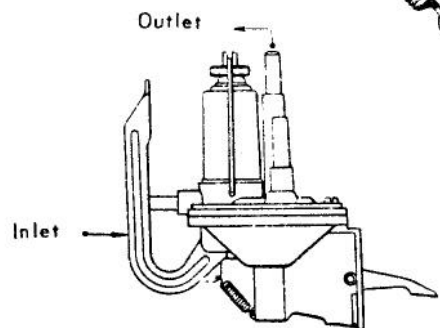
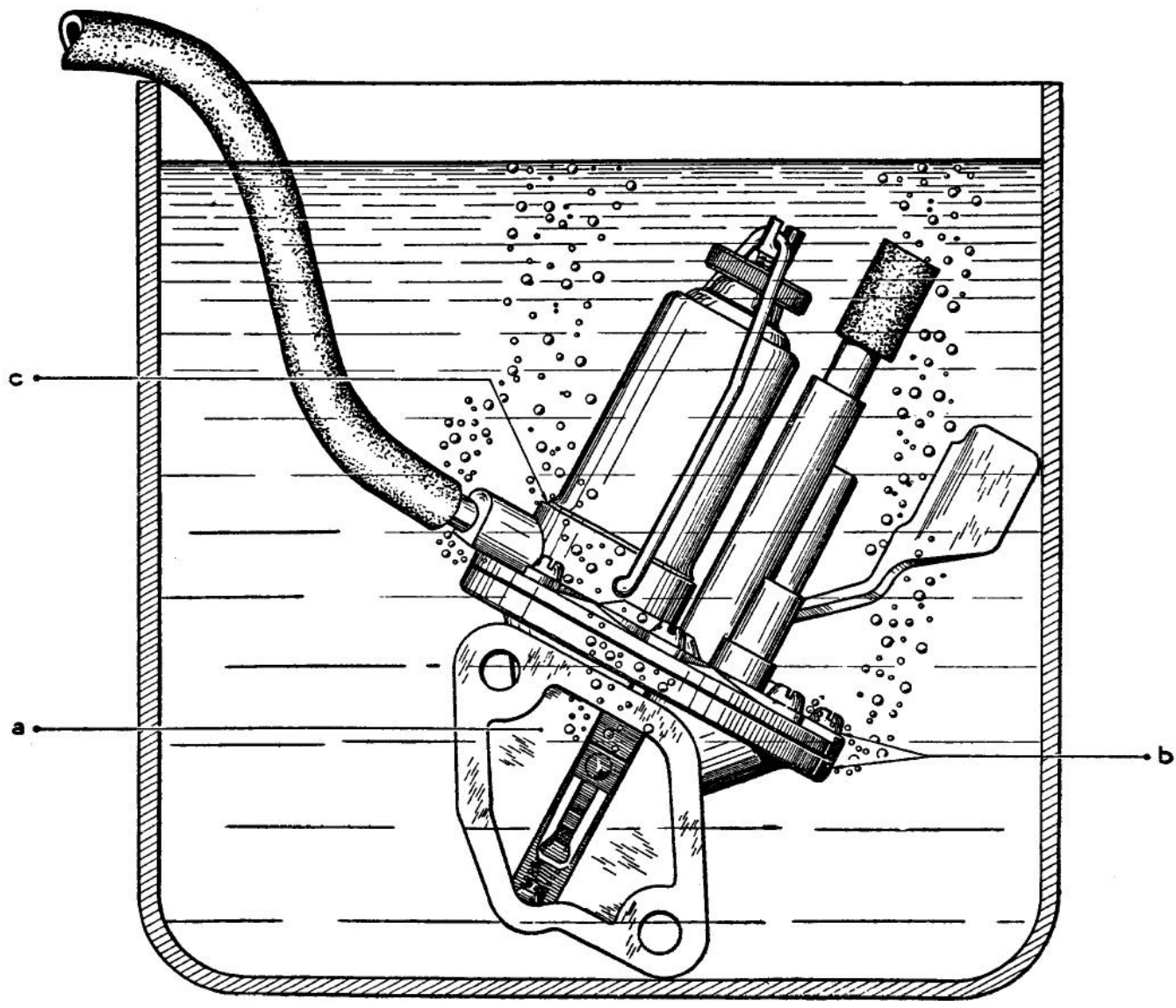

Fig 2



INSPECTION FOR LEAKS



### S. E. V. DISTRIBUTOR

Fig 1

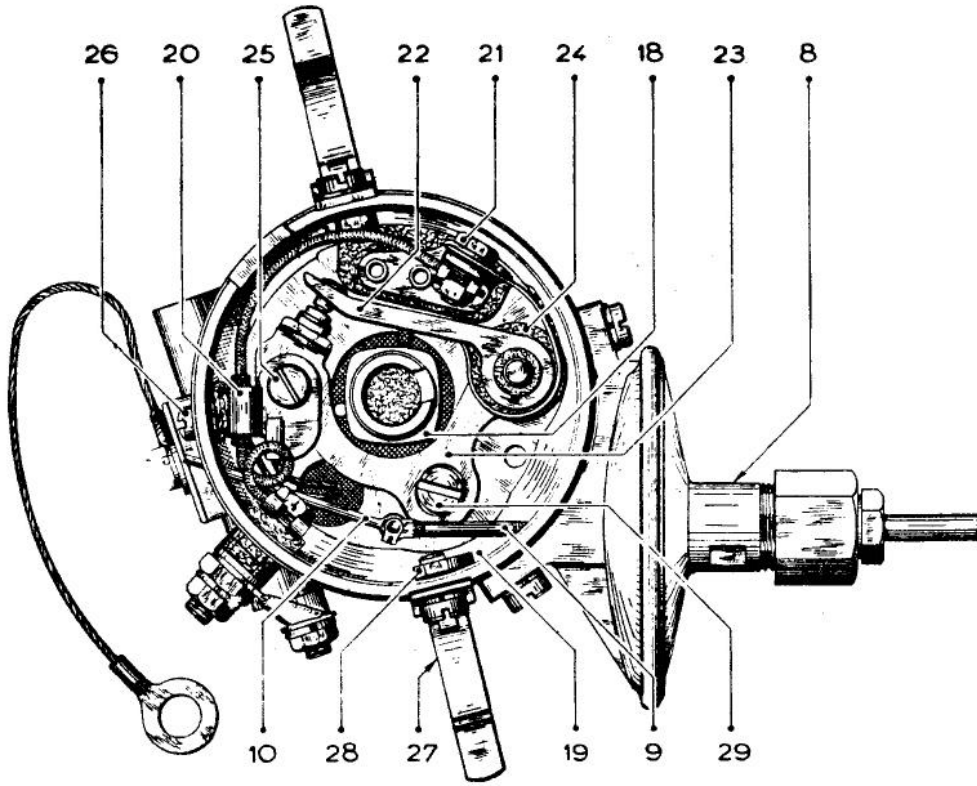

Fig 2

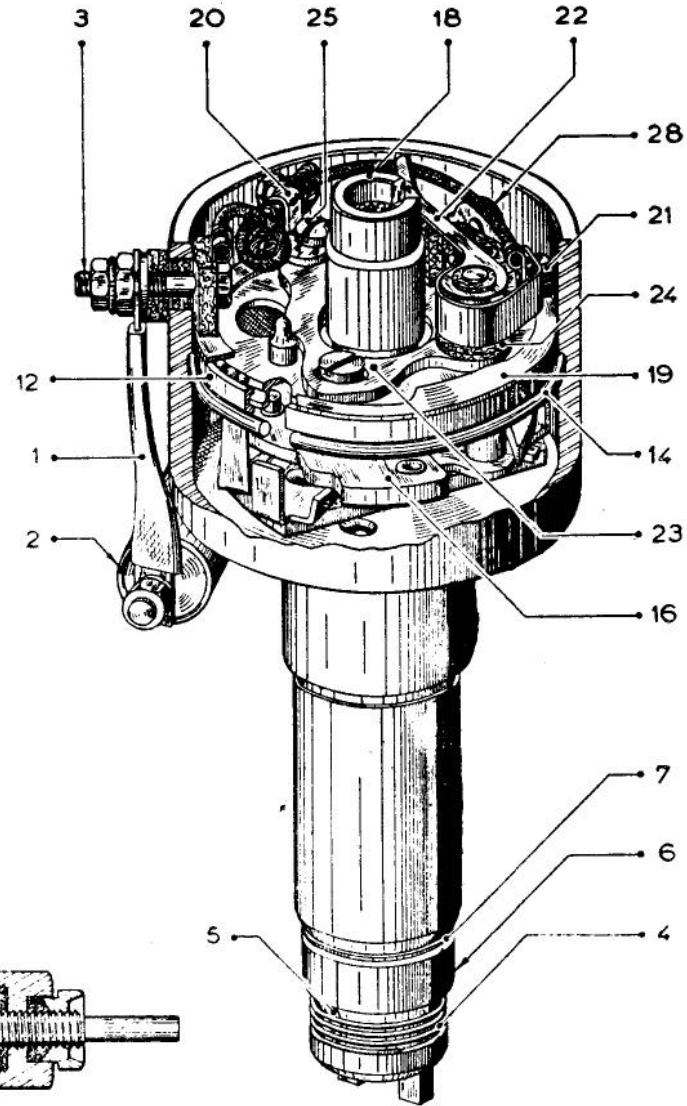

Fig 3

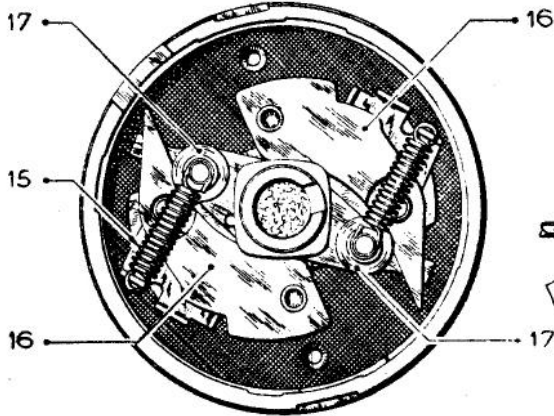
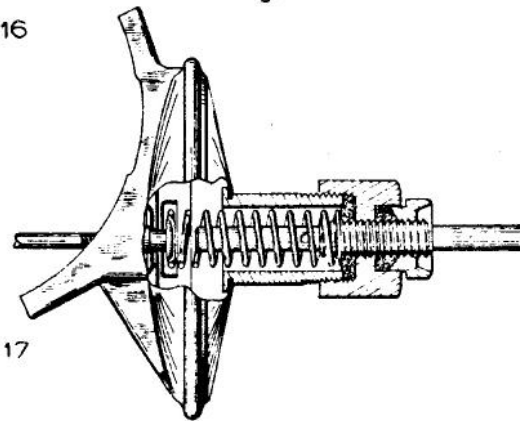
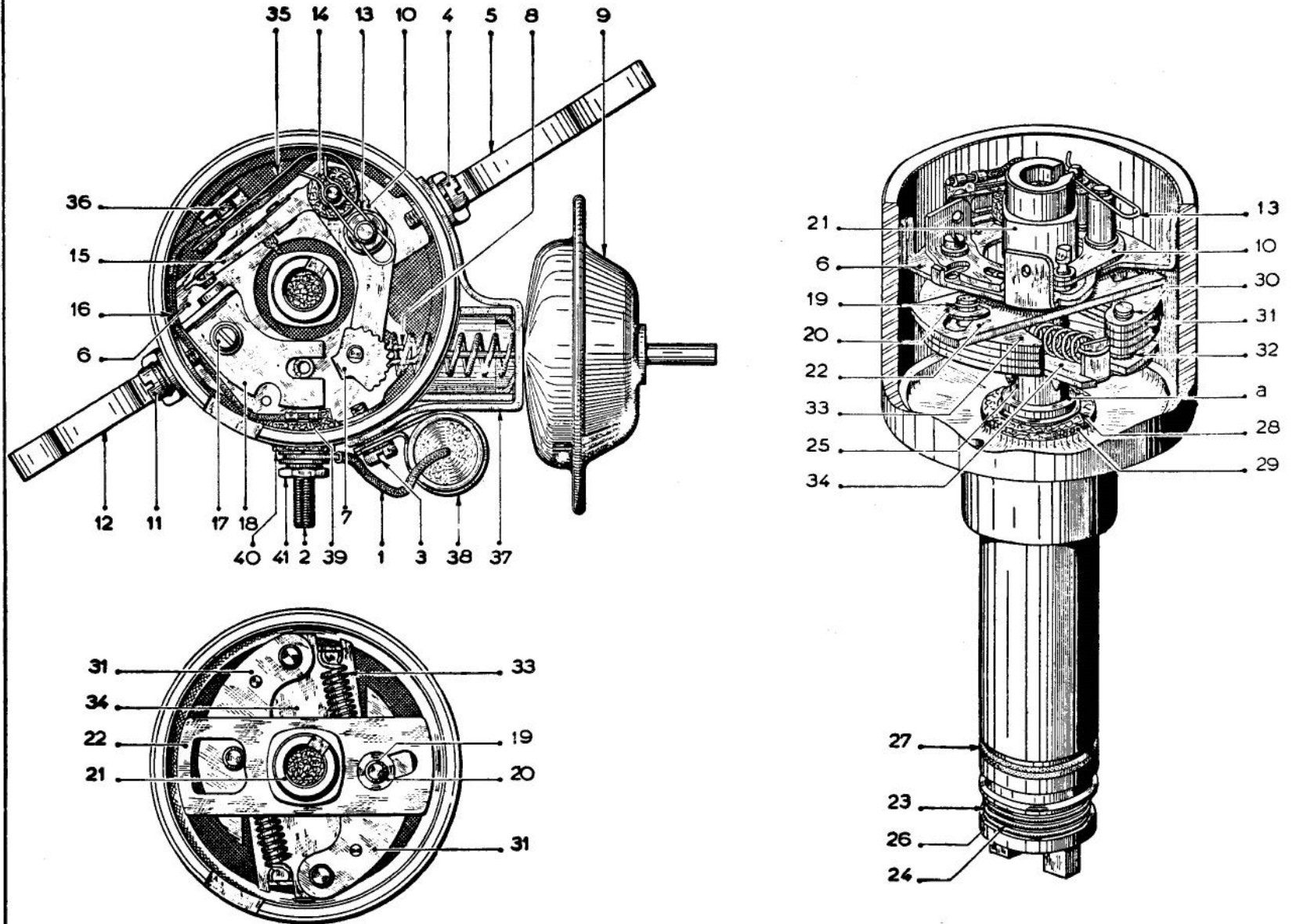

Fig 4



DUCELLIER DISTRIBUTOR



# DISTRIBUTOR

## ADVANCE CURVES

Fig. 2. SUCTION ADVANCE CURVE

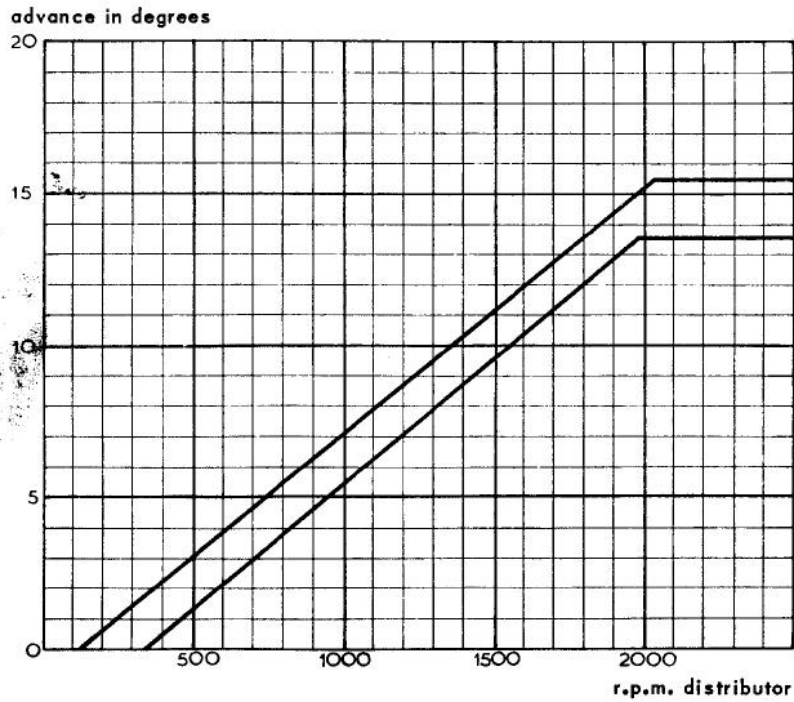
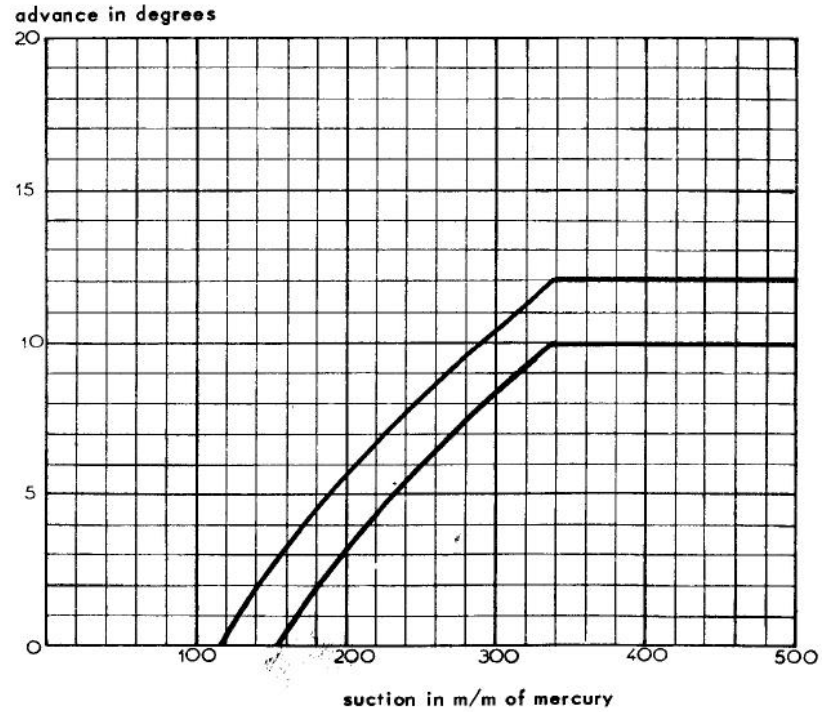
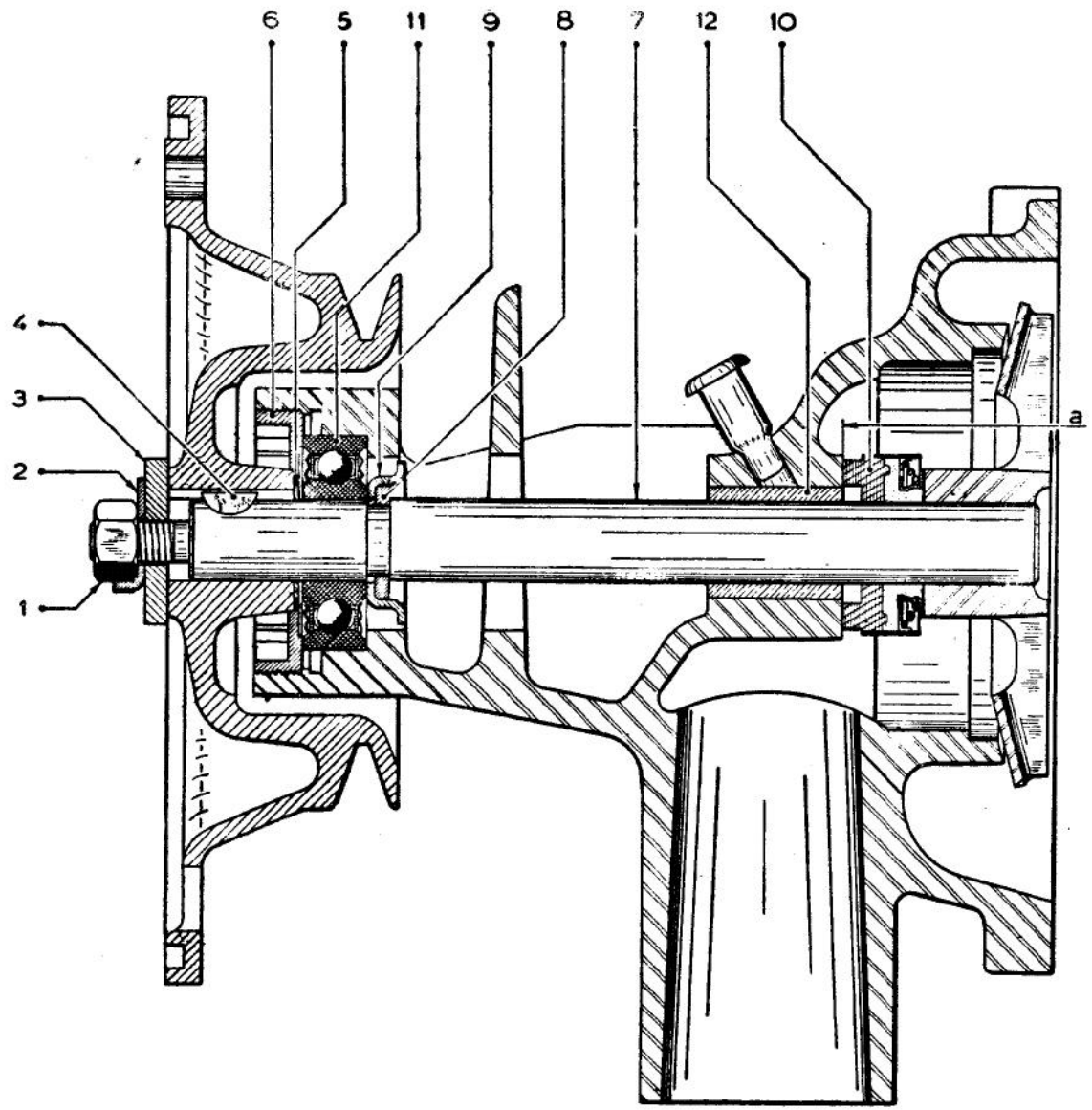

Fig. 1. CENTRIFUGAL ADVANCE CURVE



WATER PUMP





WATER PUMP

Fig. 1 SUPPORT MR-3676-180

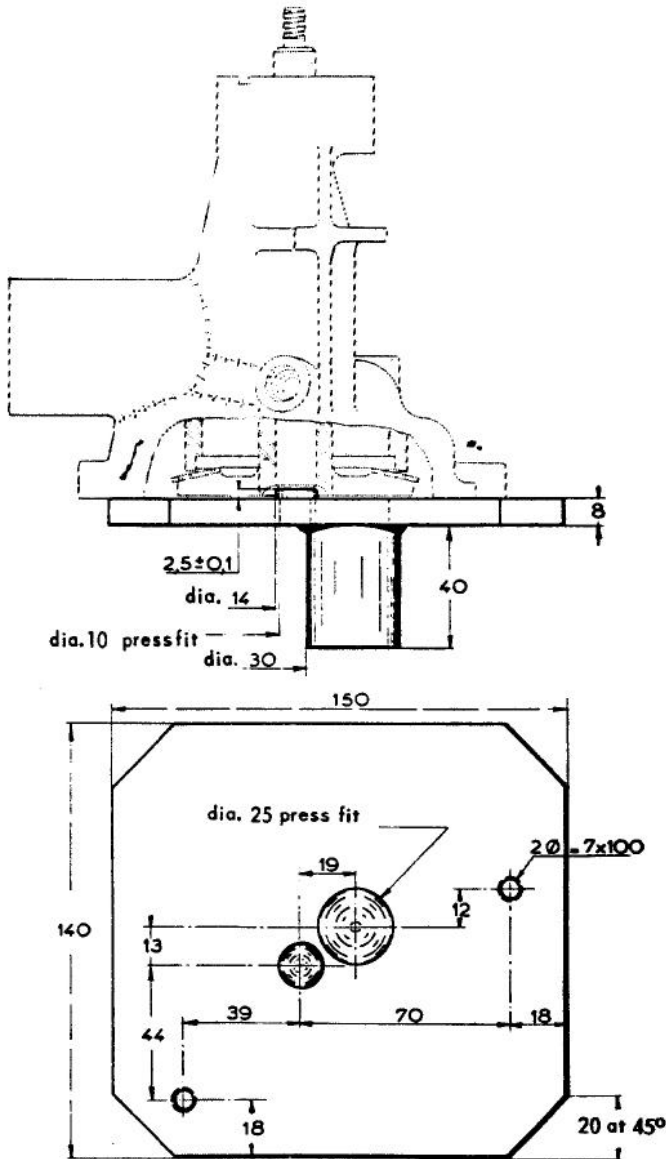

Fig. 2 - BOX SPANNER sold under No.1646-T

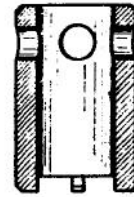

Fig. 3 - BUSH AND MANDREL MR-3676-270 not sold

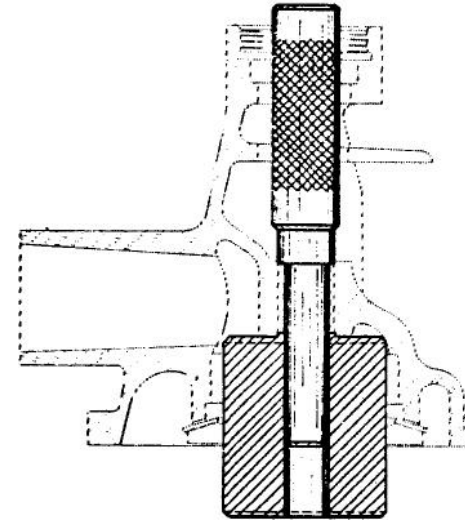
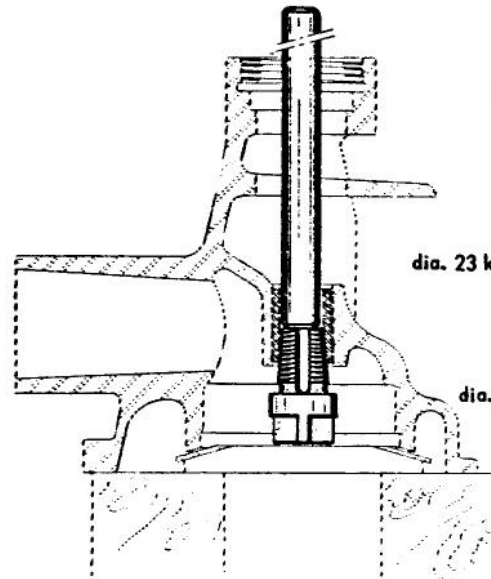
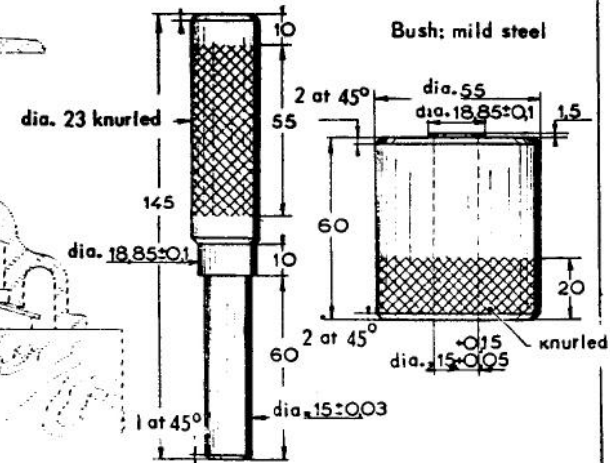

Fig. 4 - EXTRACTOR TAP sold under No.2291-T



Mandrel - mild steel

2 at 45°



Bush: mild steel

2 at 45°

2 at 45°

1 at 45°

CLUTCH  
ASSEMBLY

Fig. 1

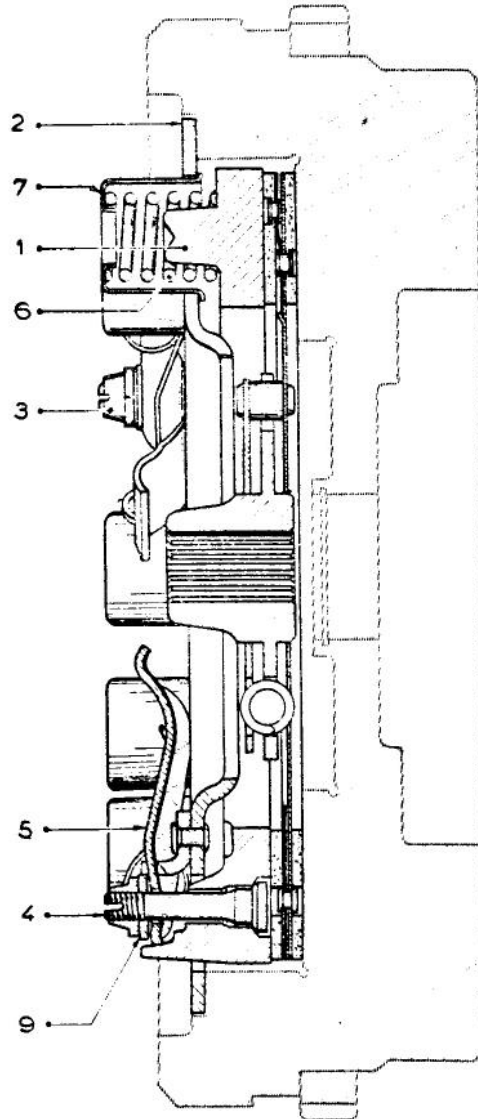

Fig. 3



Fig. 2

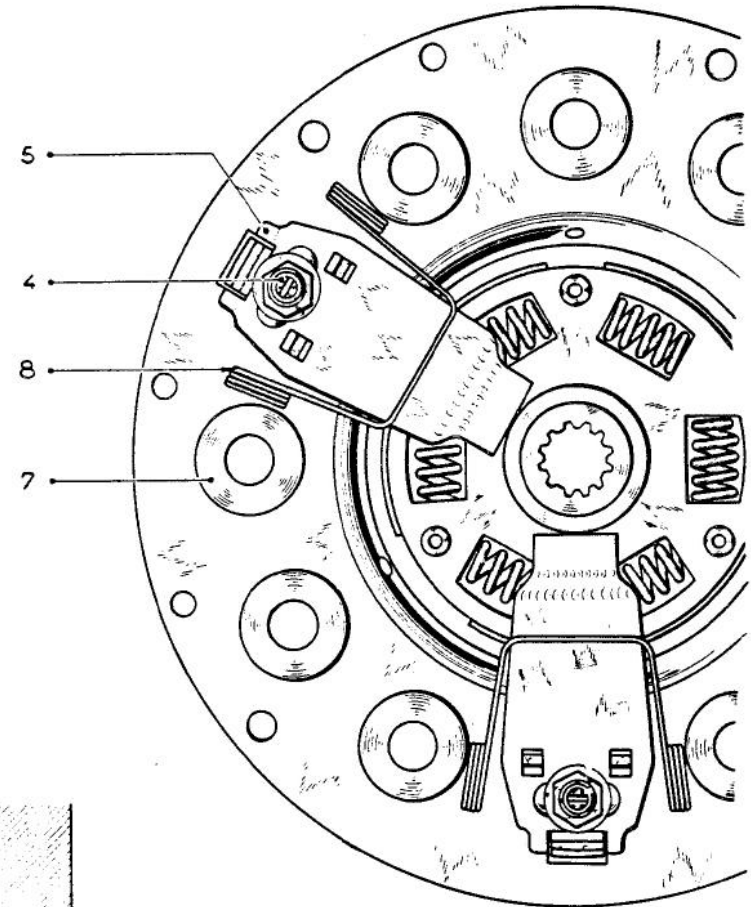
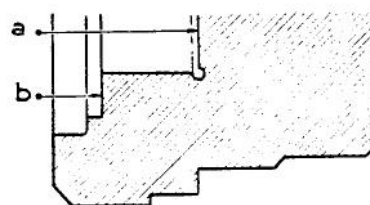

Fig. 4



GRIND THE SAME AMOUNT OFF EACH OF THE TWO FACES

## ADJUSTMENT OF THE TOGGLES

Fig. 1 - FIXTURE FOR CLUTCH ADJUSTMENT

sold under No.1701-T

THE TOGGLE PRESSURE  
CAP MUST BE REMOVED  
FOR ADJUSTMENT.

FINGER RING AND CLAMP  
sold under No.1704-T

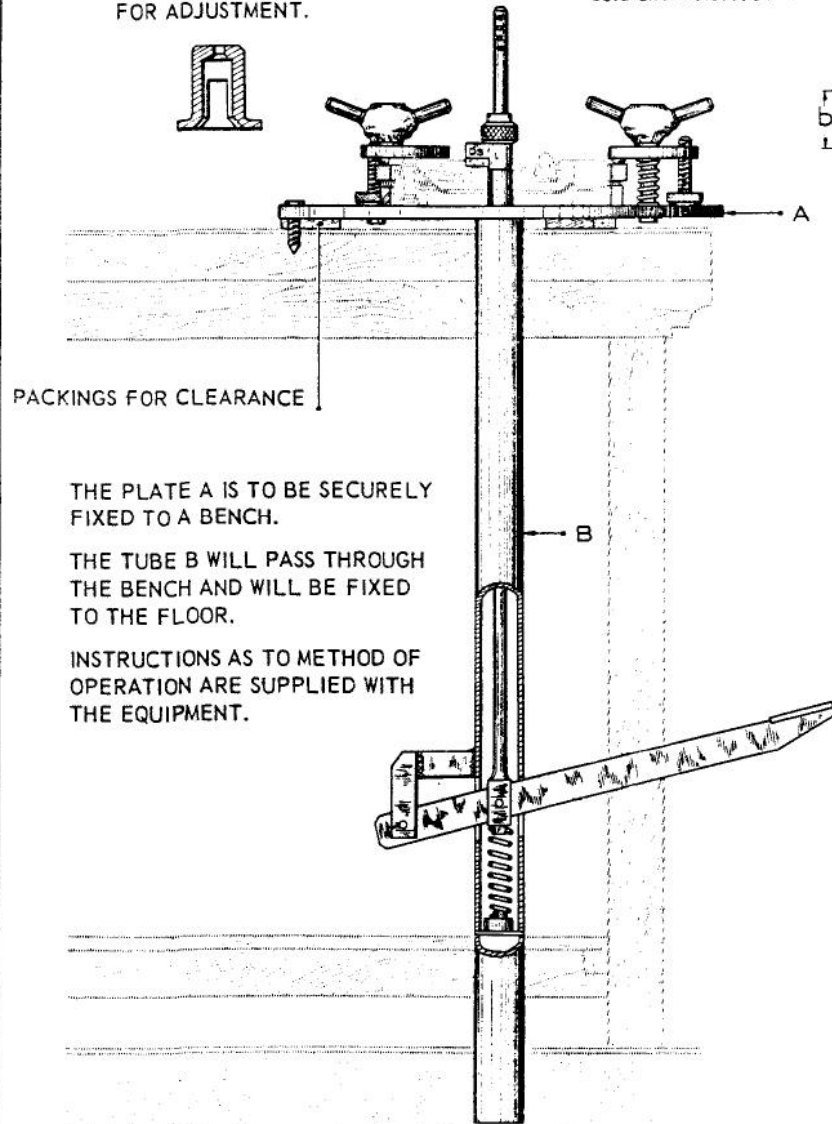

Fig. 2 - CLUTCH MECHANISM IN THE ENGAGED POSITION

THESE DIMENSIONS CAN ONLY BE MEASURED ON A  
FIXTURE

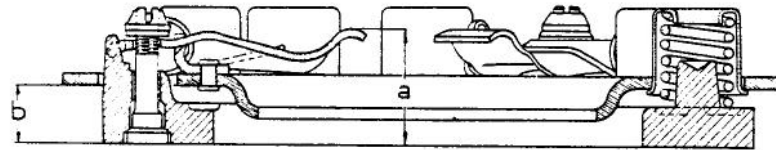
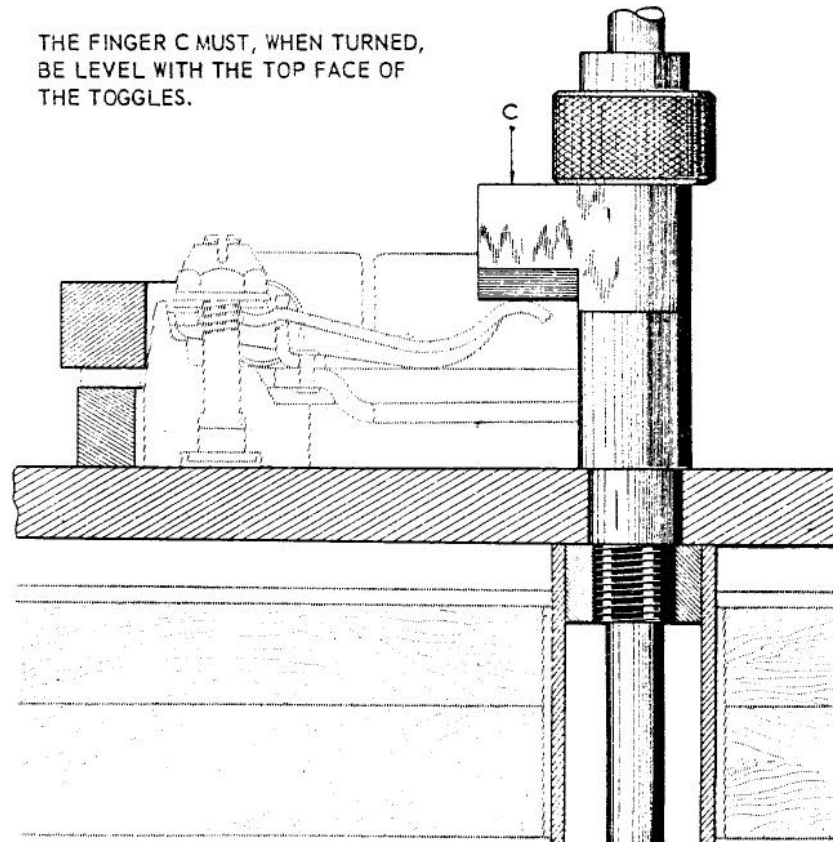

Fig. 3 - CHECKING THE ADJUSTMENT

THE FINGER C MUST, WHEN TURNED,  
BE LEVEL WITH THE TOP FACE OF  
THE TOGGLES.



## ADJUSTMENT OF THE TOGGLES

Fig 1 - ADJUSTMENT

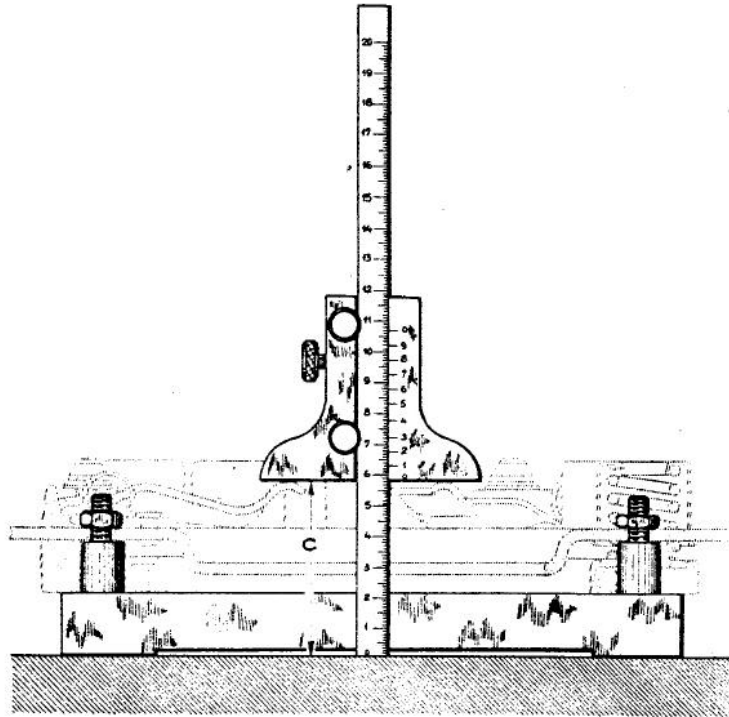

Fig 2 - ASSEMBLY OF THE BLOCKS

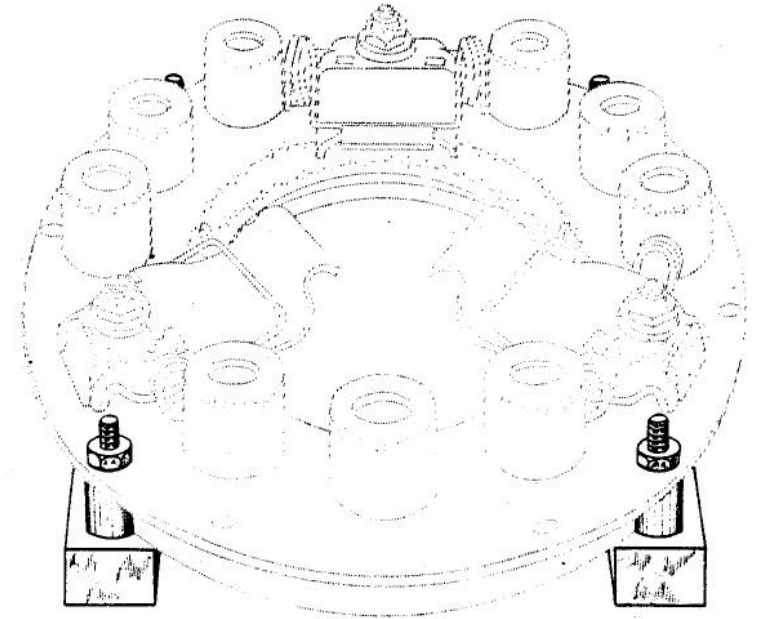

Fig 3 - BLOCK MR-3457-100

not sold

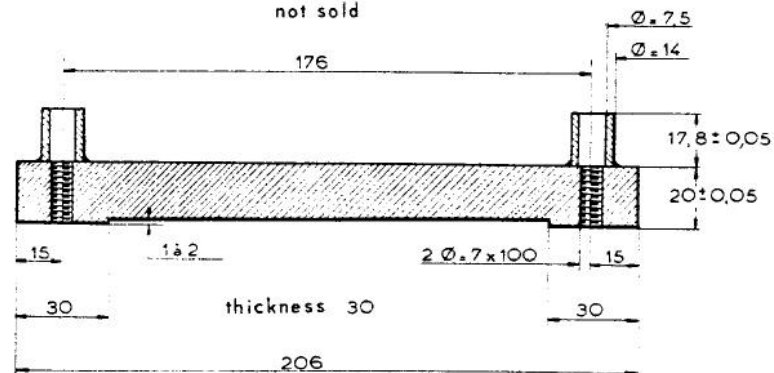
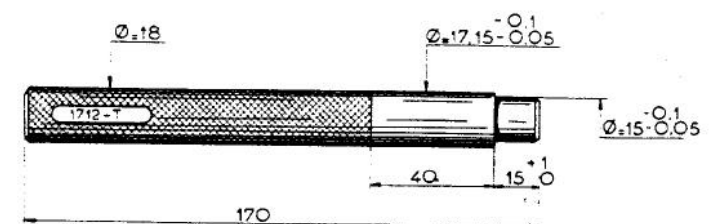
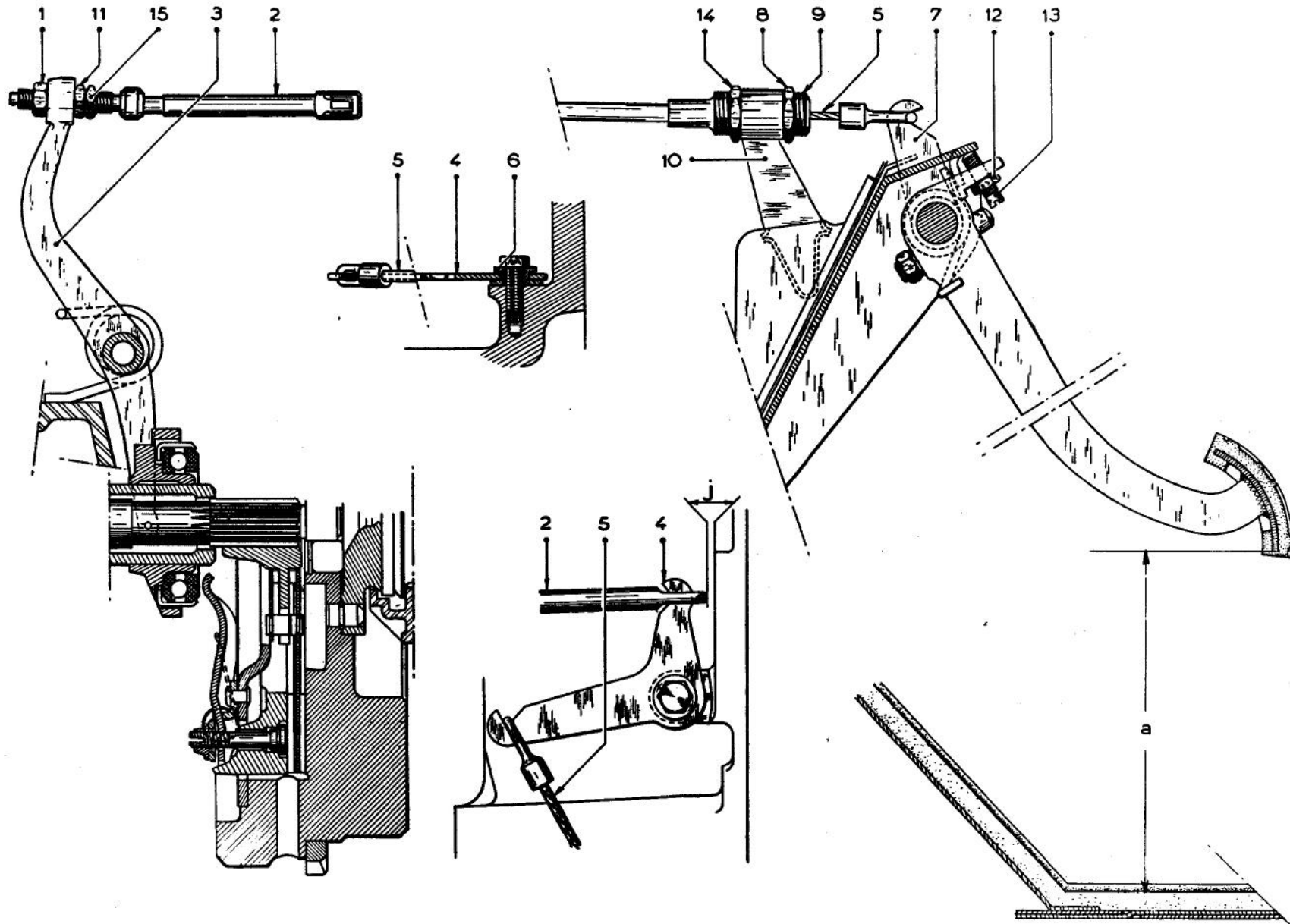

Fig 4 - MANDREL

sold under No. 1712-T



CLUTCH CONTROL



REMOVAL AND REPLACEMENT

SUPPORT FIXTURE

sold under No.1799-T

ENGINE STAND

sold under No.1797-T

CHAIN SLING

sold under No.1697-T

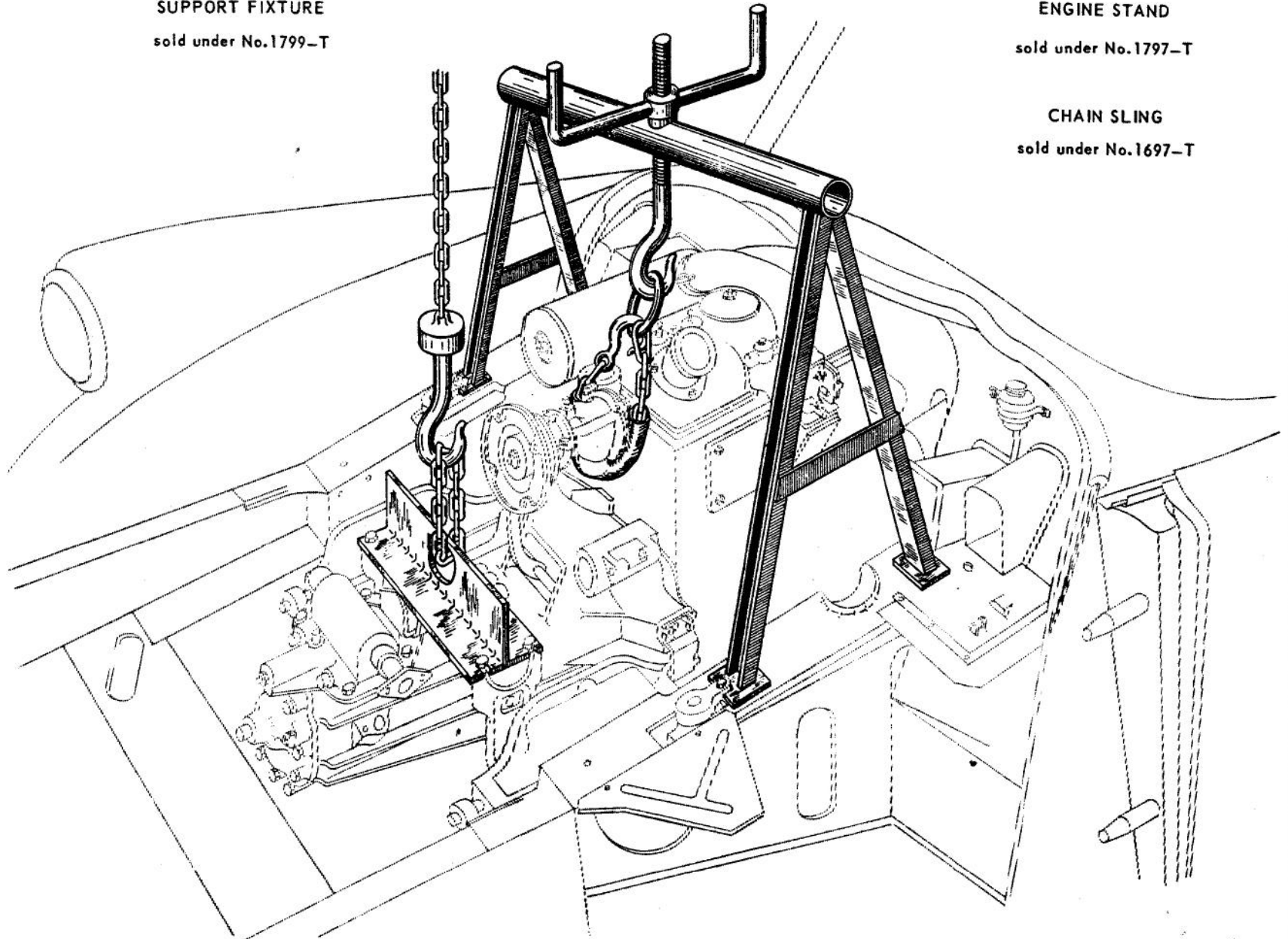

ASSEMBLY

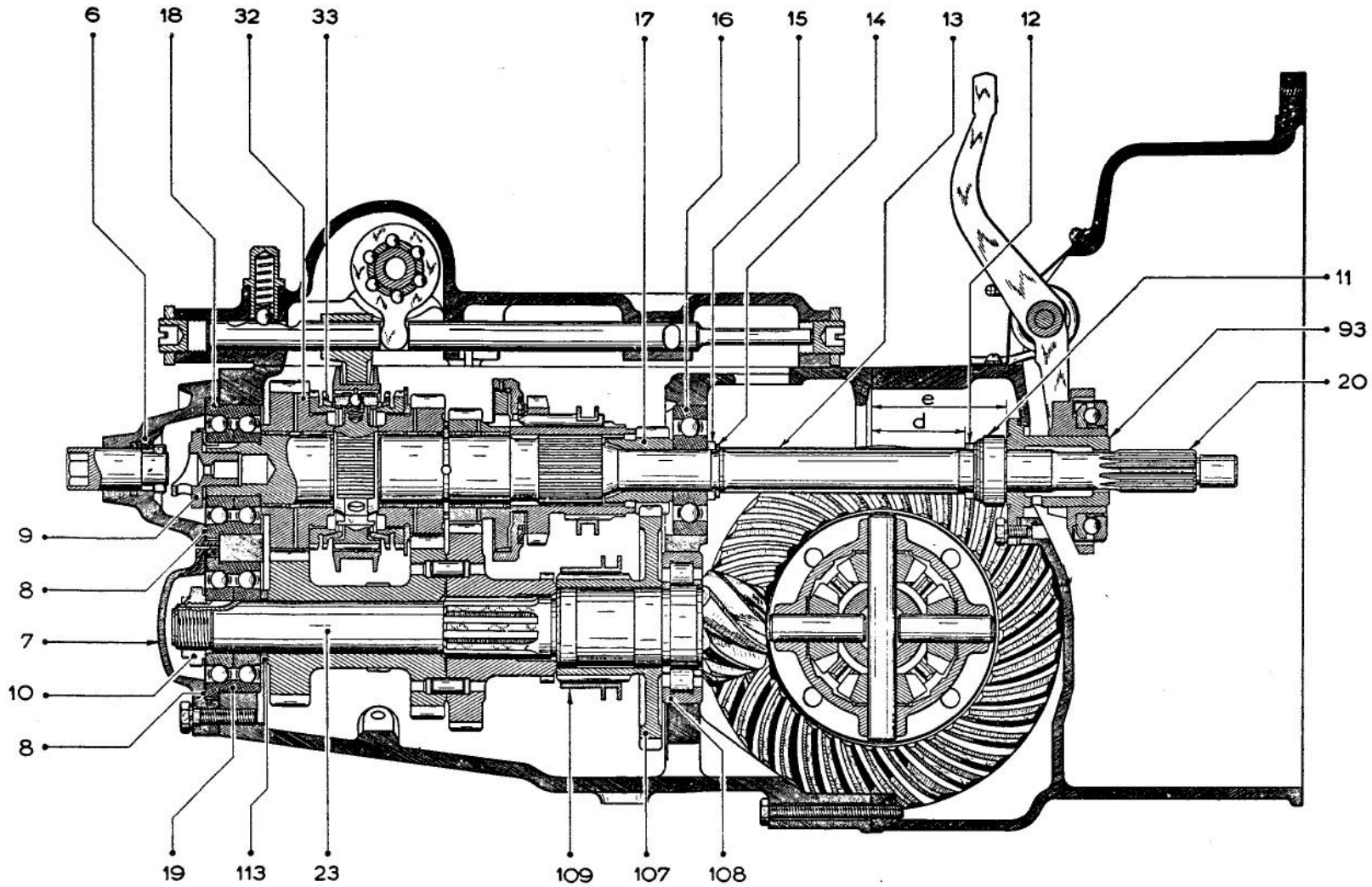

# SHAFTS

Fig.1 - MAIN SHAFT

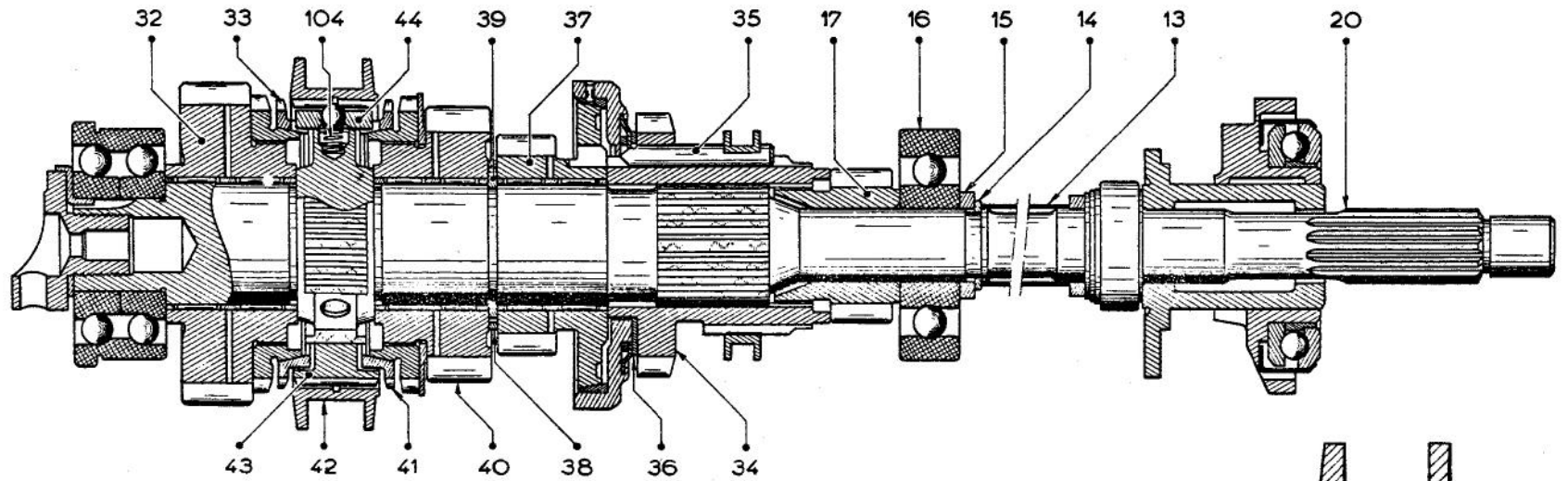
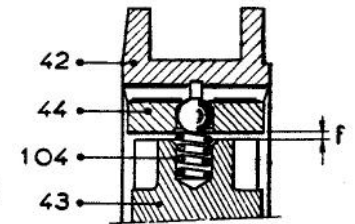
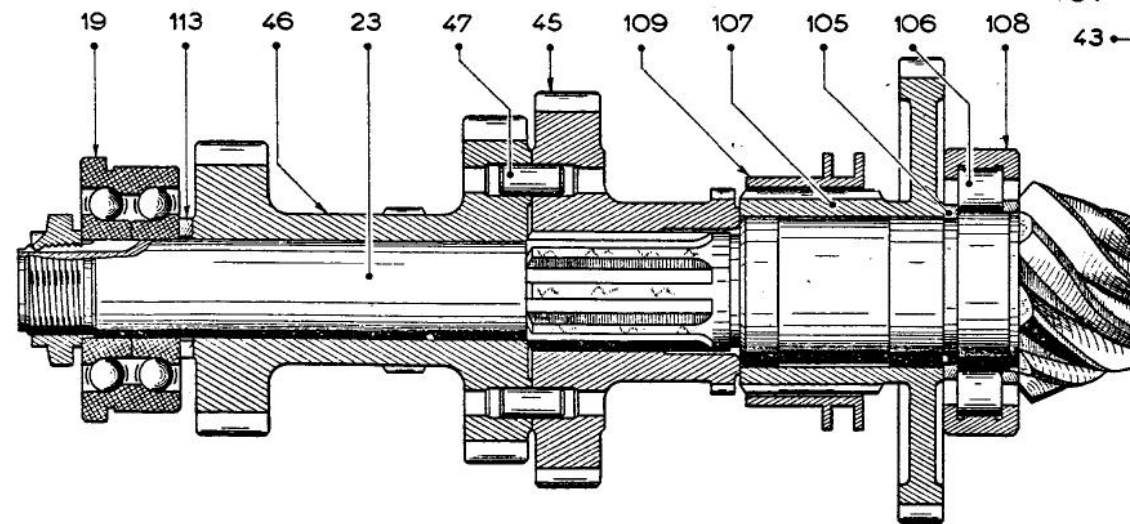

Fig 2 - BEVEL PINION SHAFT





### ASSEMBLY OF PINIONS

Fig. 1

teeth entry at 15°

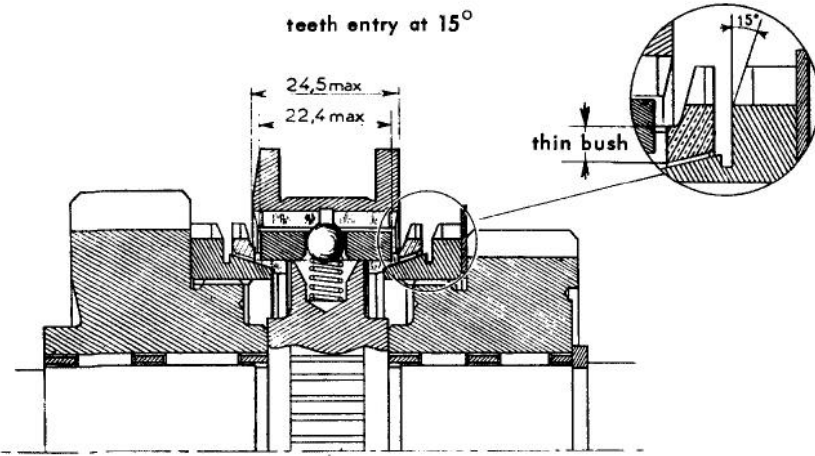

Fig. 2

teeth entry straight

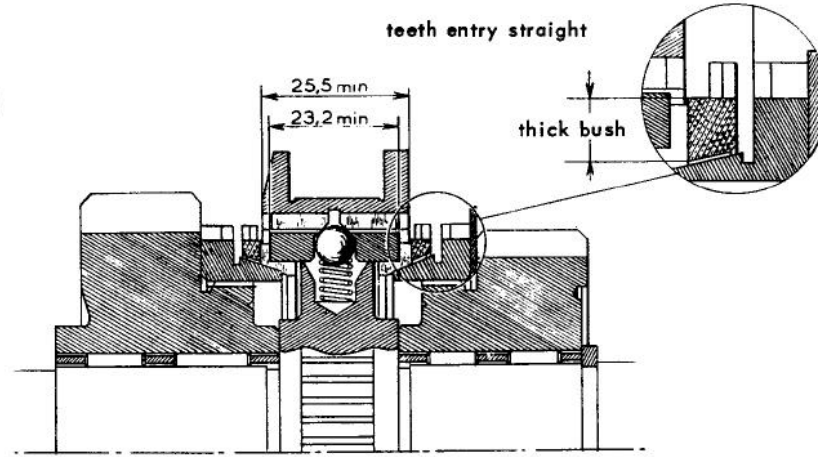

Fig. 3

4th speed mainshaft pinion

3rd speed mainshaft pinion

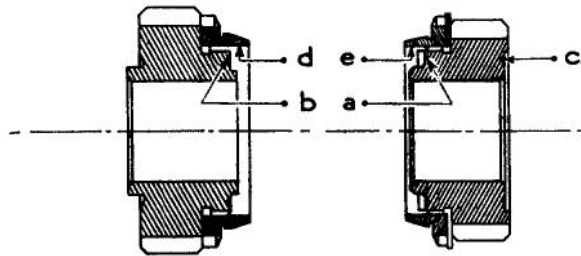
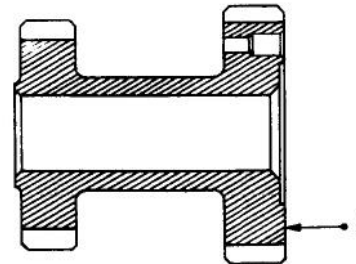

Fig. 4

Intermediate train



DIFFERENTIAL

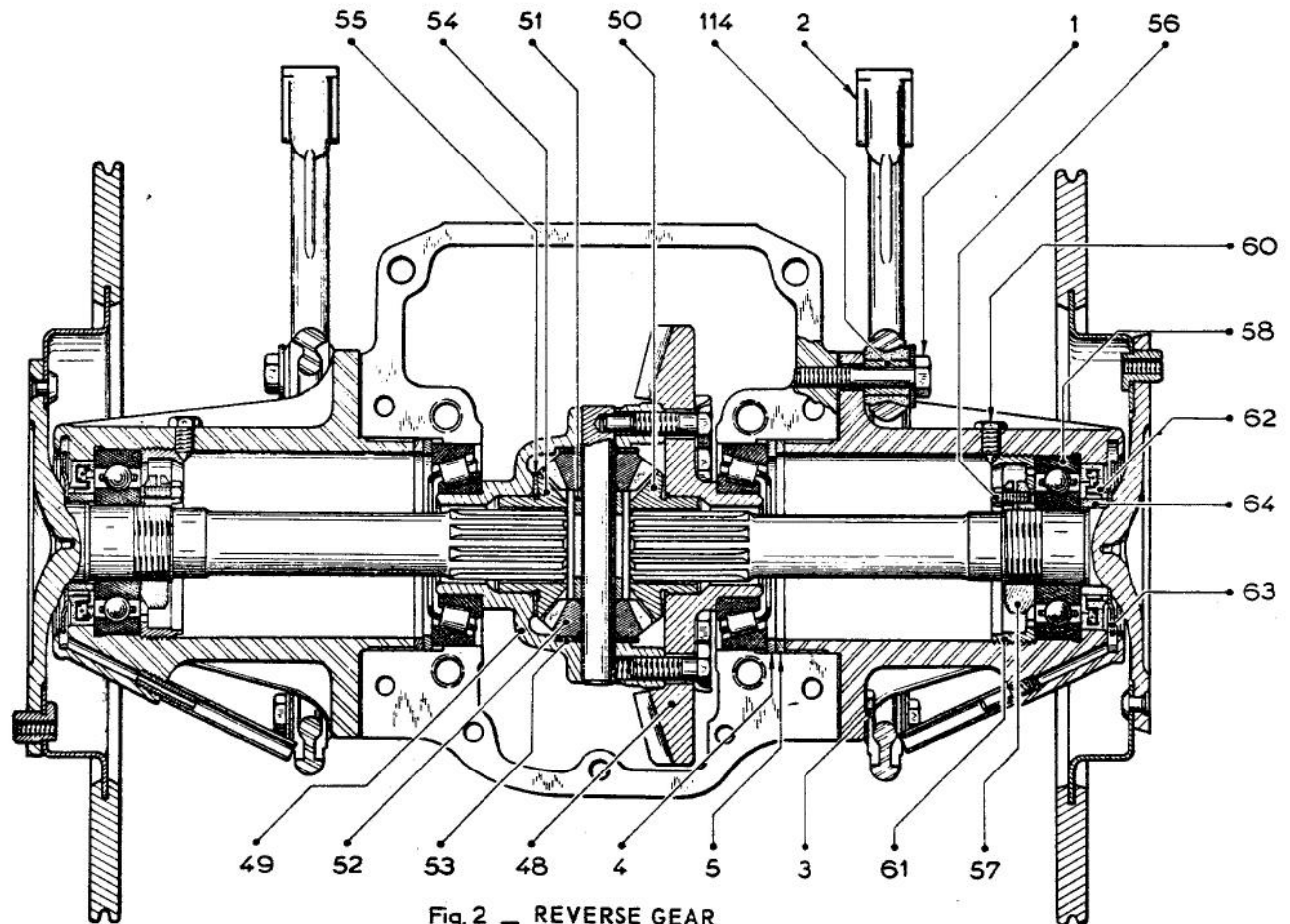
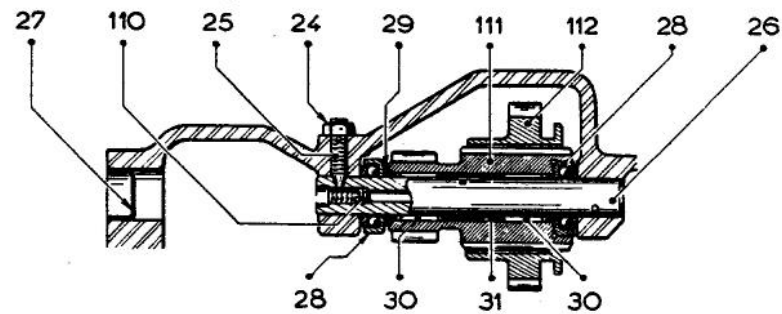

Fig. 2 - REVERSE GEAR



REVERSE SPEED PINION

Fig.1 MAINSHAFT ASSEMBLY

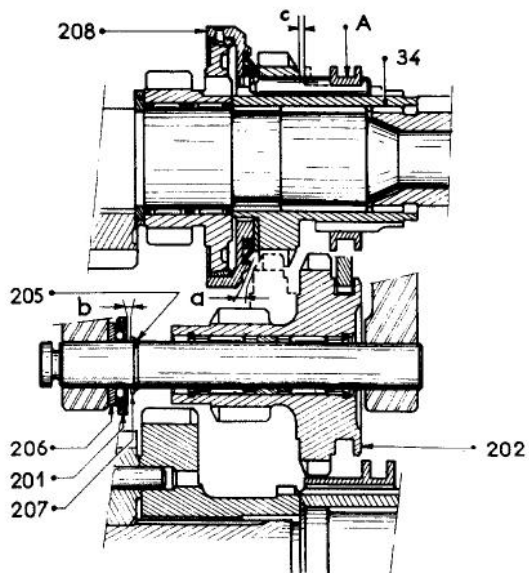

Fig.2 SETTING THE DIAL GAUGE

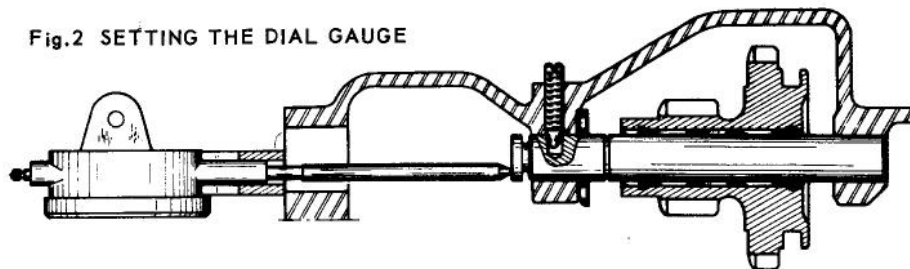

Fig.3 ADJUSTMENT OF THE REVERSE SPEED SLIDING PINION

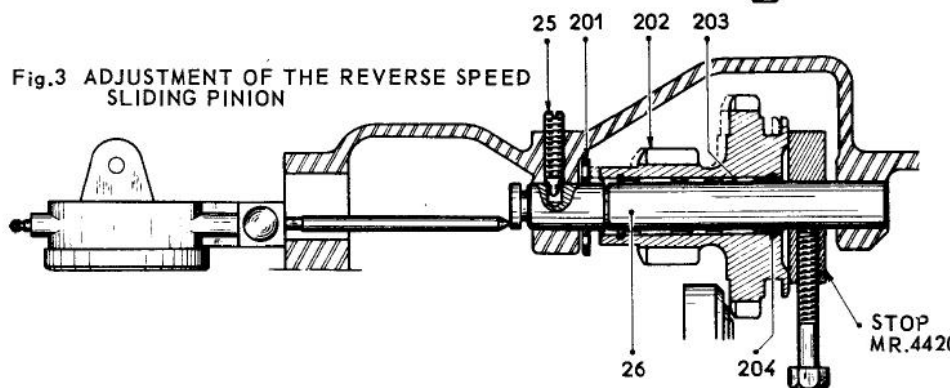

Fig.6 STOP MR.4420  
not sold

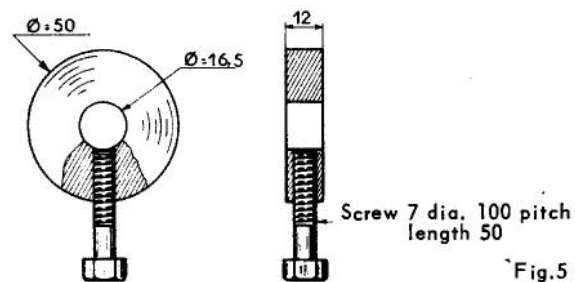

Fig.7 STRAIGHT EDGE SUPPORT  
sold under No.1754-T



Fig.5 TOUCHE  
sold under No.2441-T

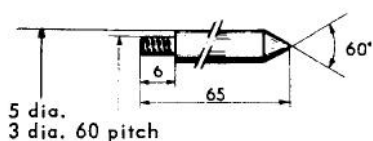
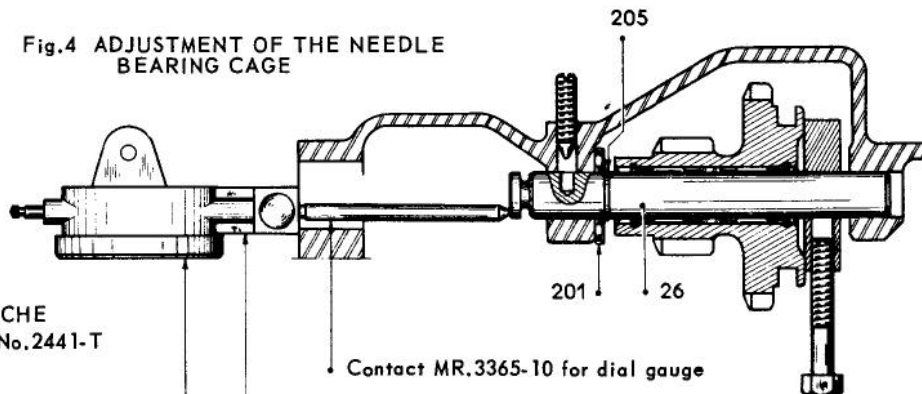

Fig.4 ADJUSTMENT OF THE NEEDLE BEARING CAGE



• Contact MR.3365-10 for dial gauge  
• Straight edge support for dial gauge  
• Dial gauge sold under No.2437-T

COVER

LEVERS OPERATING THE SELECTOR SHAFTS

view in direction of arrow F

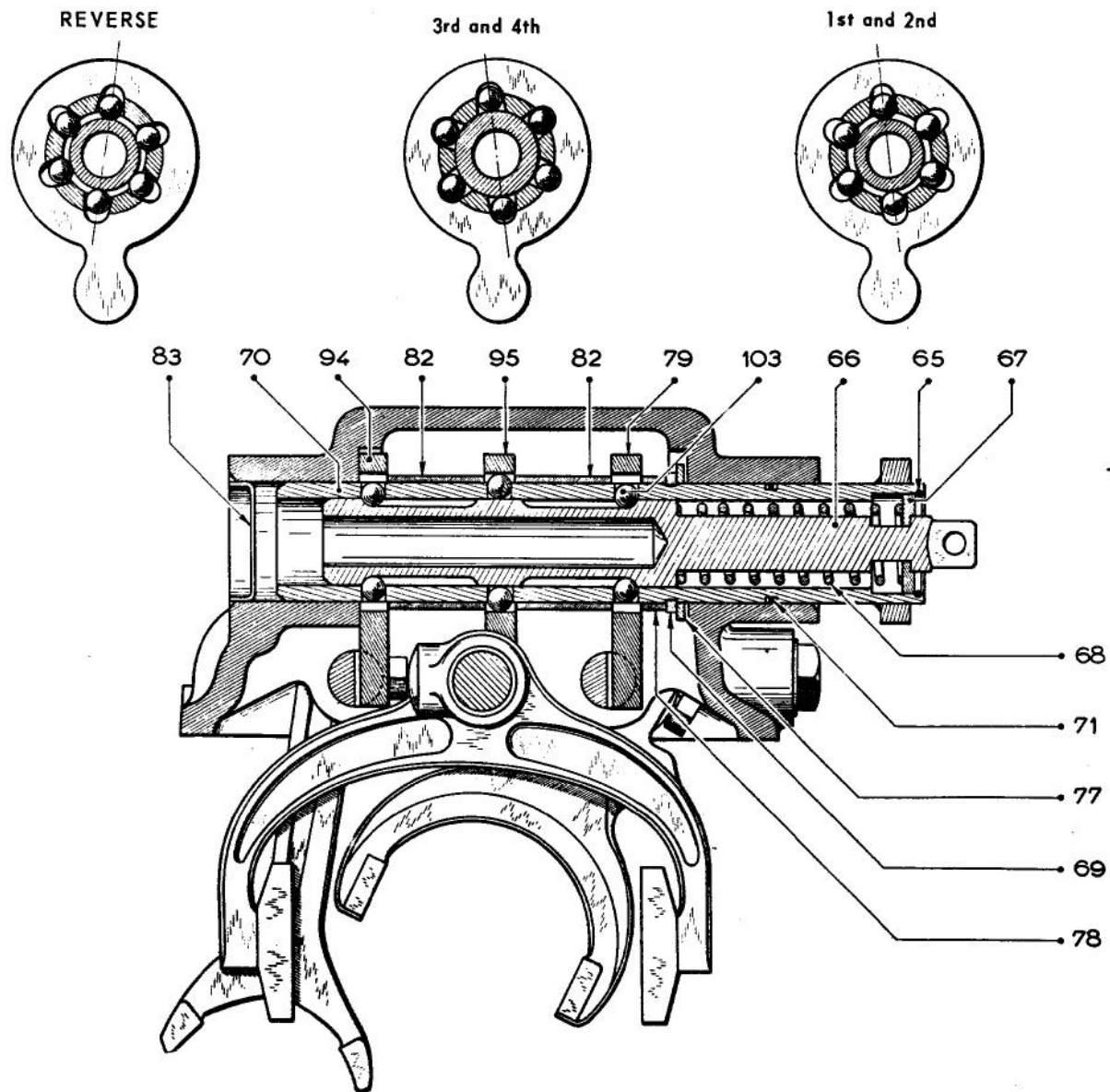

Fig.1

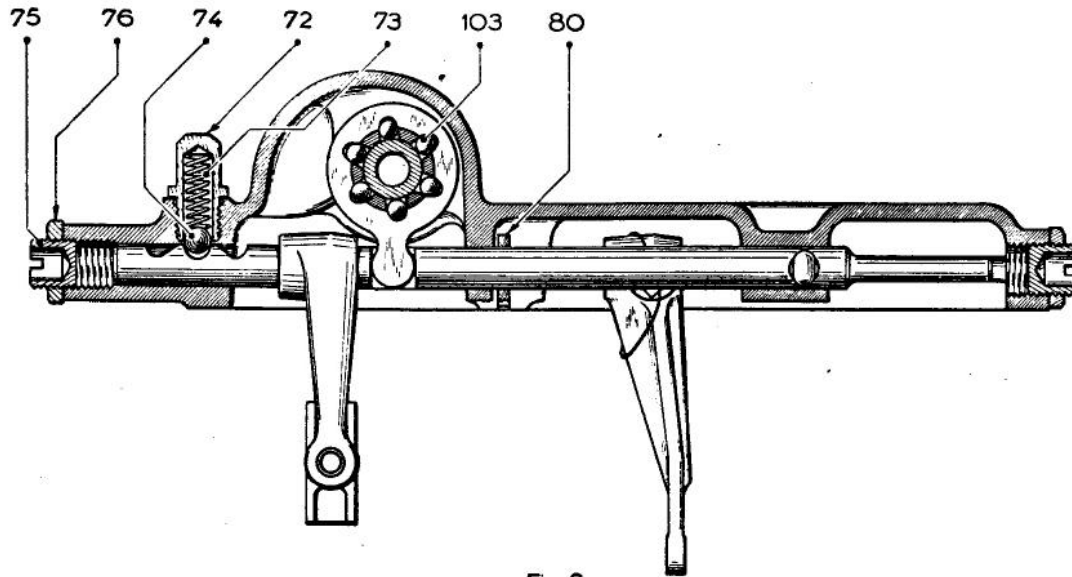
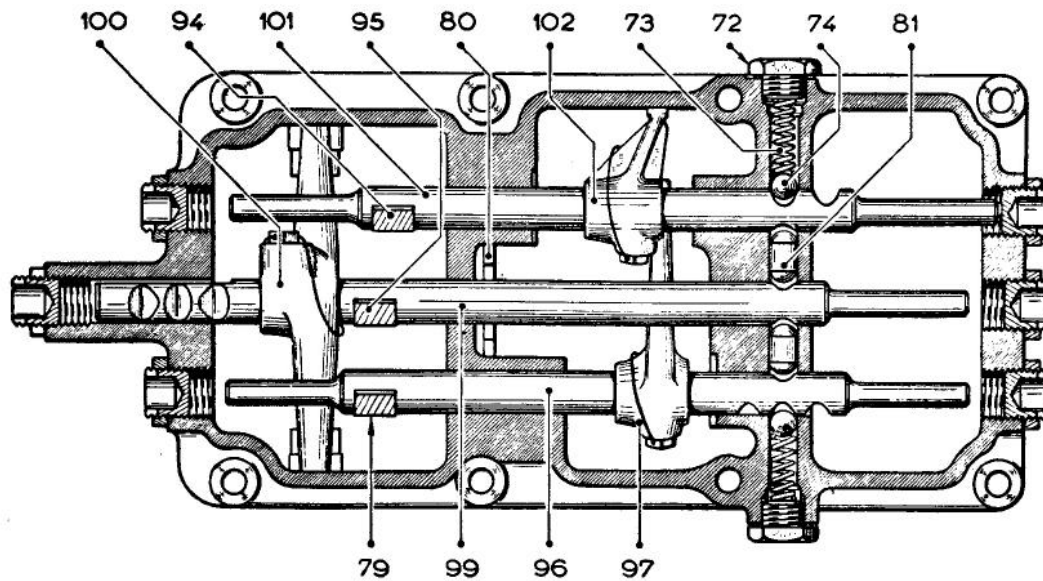

Fig. 2



FIRST SPEED SELECTOR LEVER

Fig. 1

Fig. 2

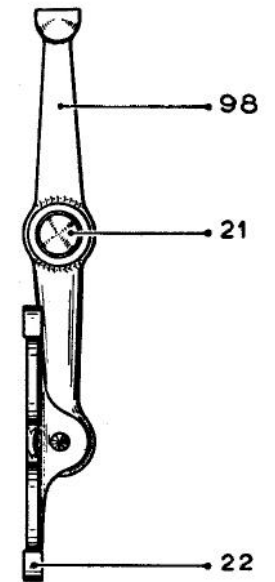
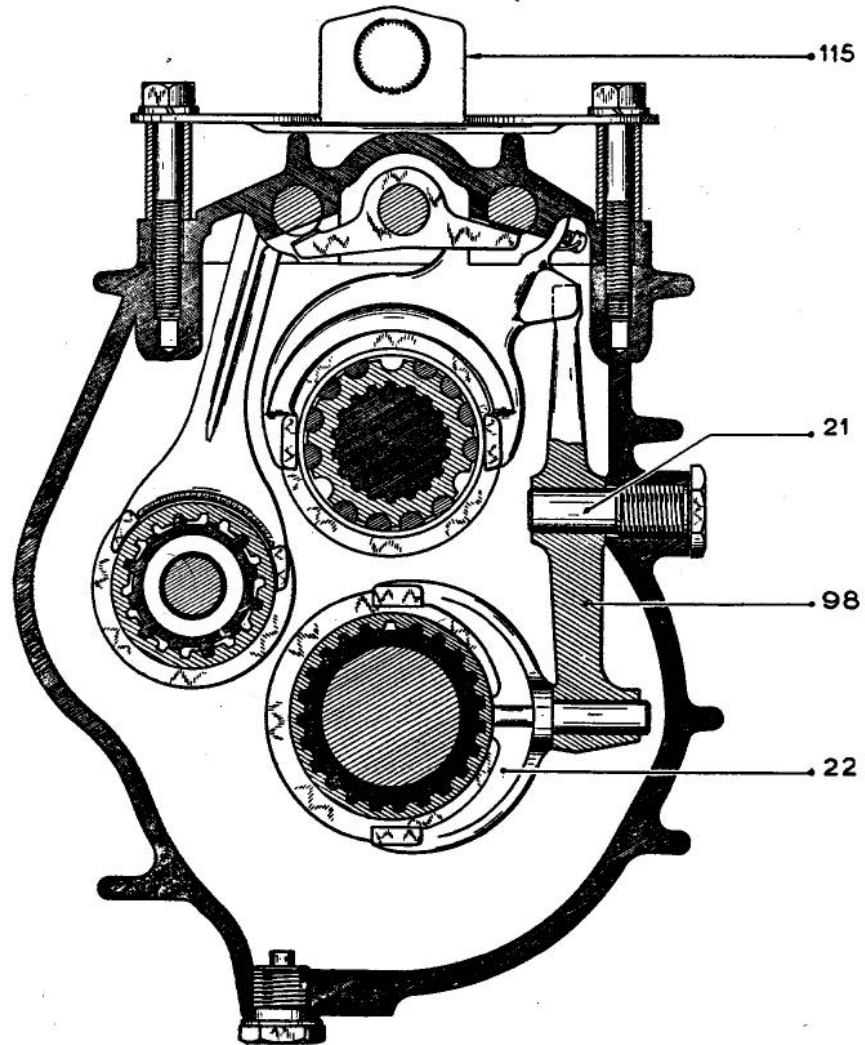

OPERATIONS  
ID 231-4  
ID 314-4  
ID 330.2  
ID 330-3

GEARBOX

ID 19

49

CLUTCH HOUSING

Fig.1

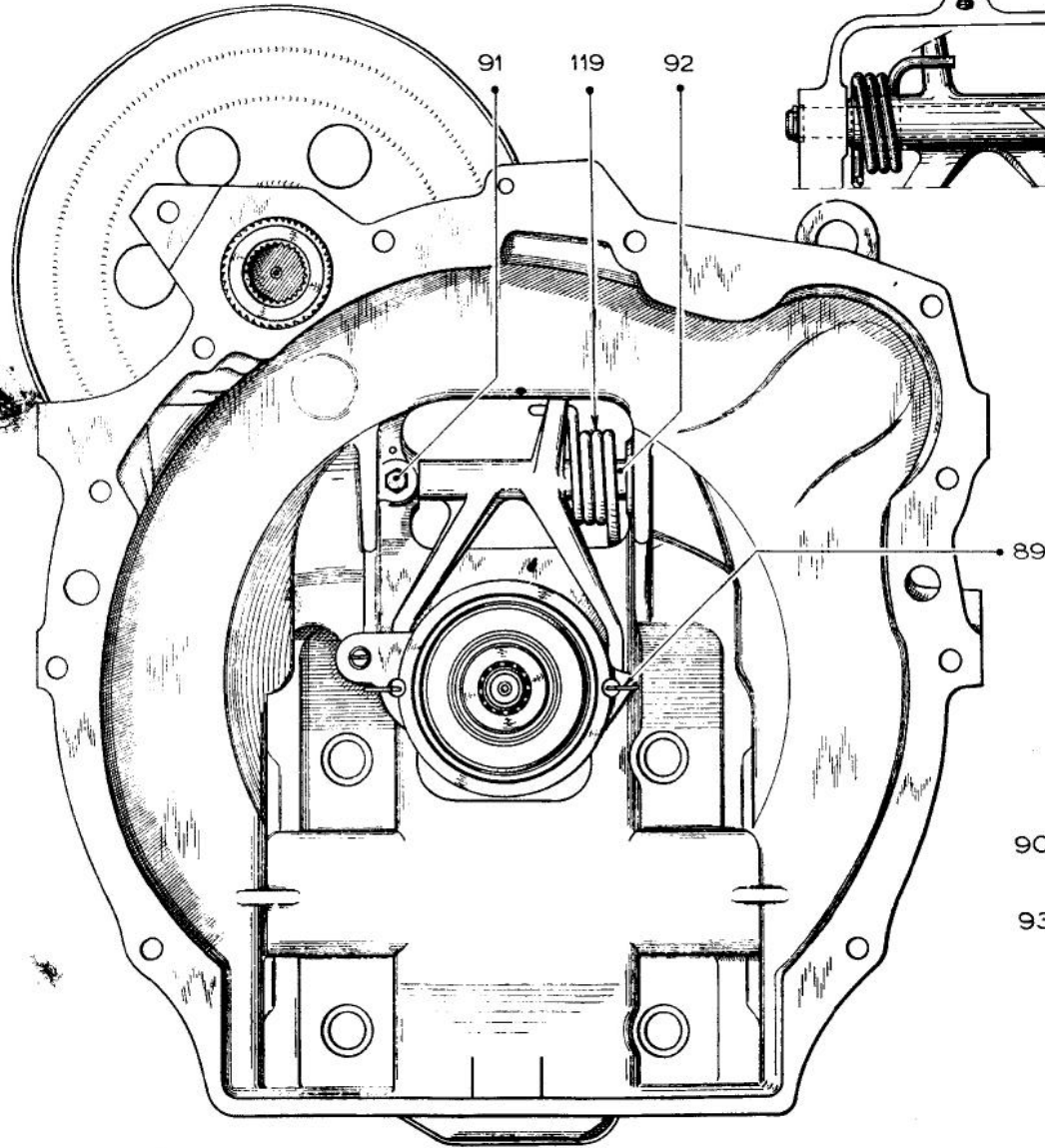

Fig.3

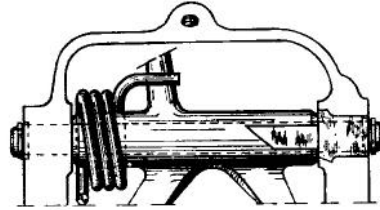
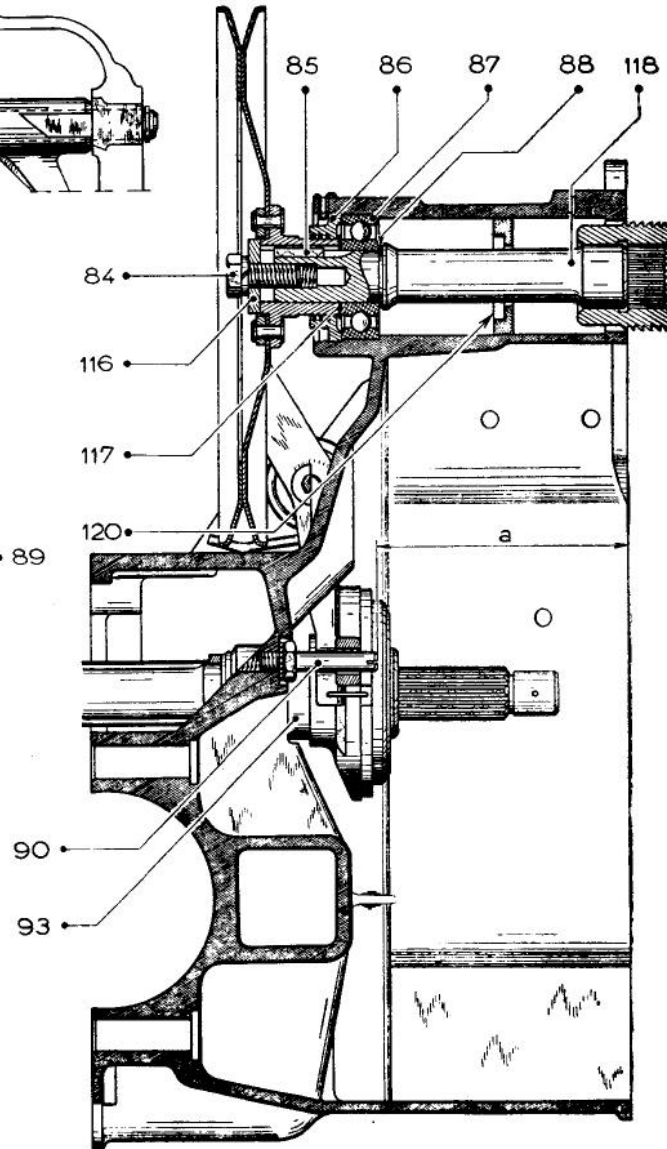
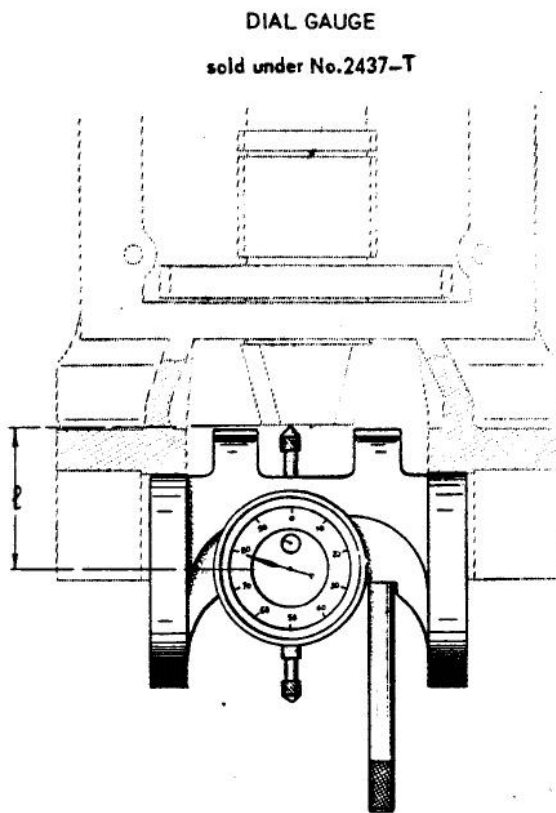

Fig. 2



# ADJUSTMENT OF CROWN WHEEL AND BEVEL PINION

Fig.1 - ADJUSTMENT OF BEVEL PINION SETTING



ADJUSTING FIXTURE

sold under No.2044-T

PAIRING NUMBER

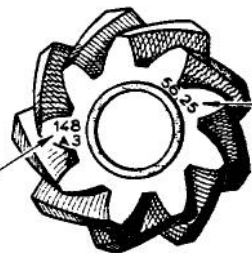

BEVEL PINION SETTING

Fig.2 - ADJUSTMENT OF TOOTH CLEARANCE

SUPPORT FOR DIAL GAUGE

sold under No.2039-T

EXTENSION

sold under No.2439-T

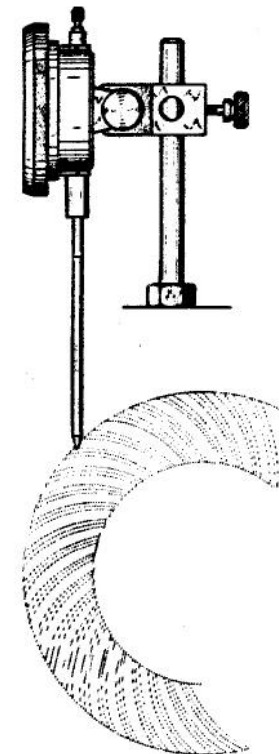
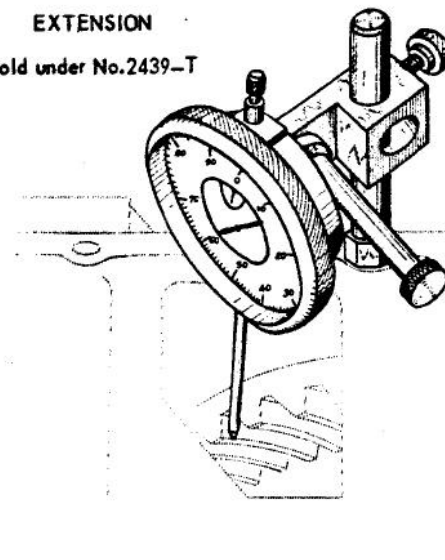
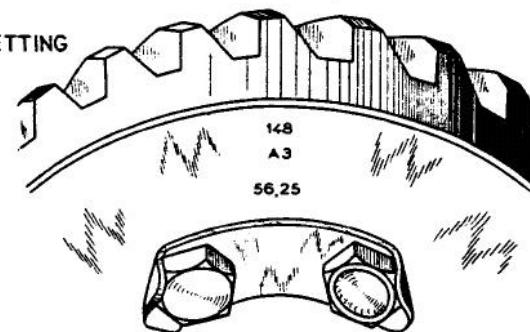

Fig.3 - MARKING





# ADJUSTMENT OF THE DIFFERENTIAL BEARINGS

Fig.1 - MEASURING THE DEPTH OF THE HOUSING

Fig.2 - MEASURING THE HEIGHT OF THE SHOULDER OF THE HUB

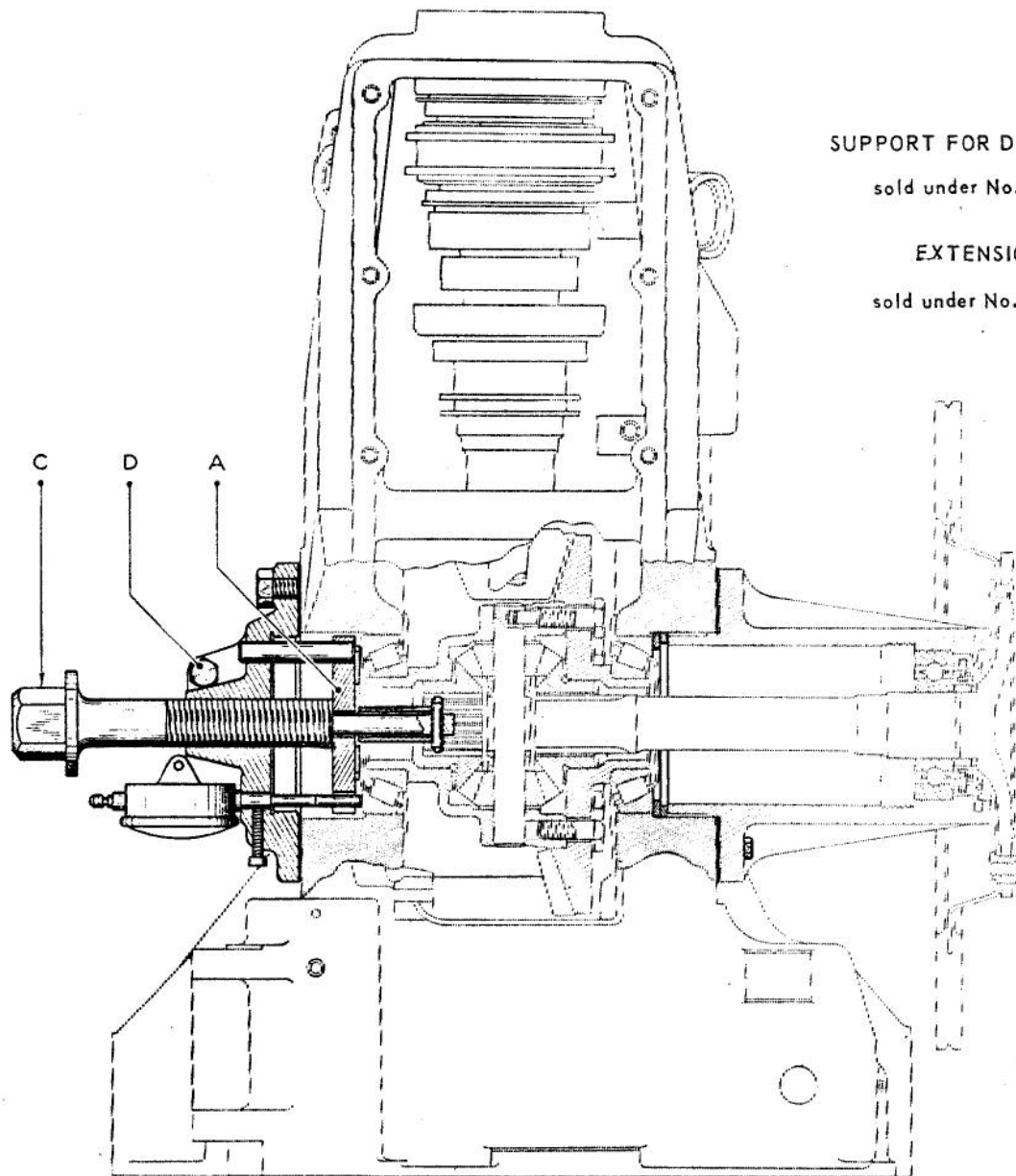

SUPPORT FOR DIAL GAUGE

sold under No.1766-T

EXTENSION

sold under No.2438-T

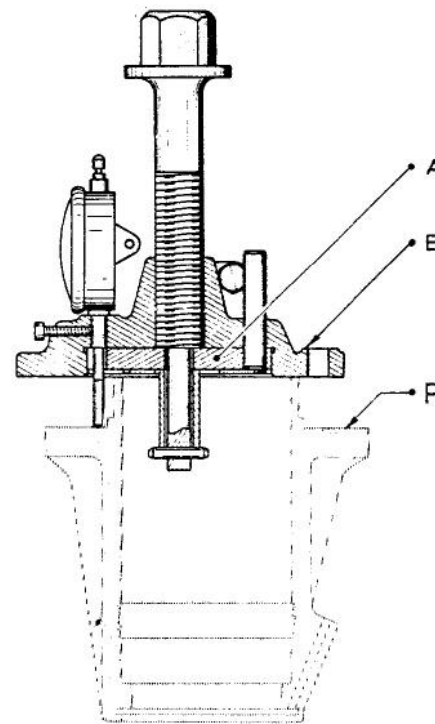

DIFFERENTIAL BEARING

Fig.1 - EXTRACTION OF BEARING

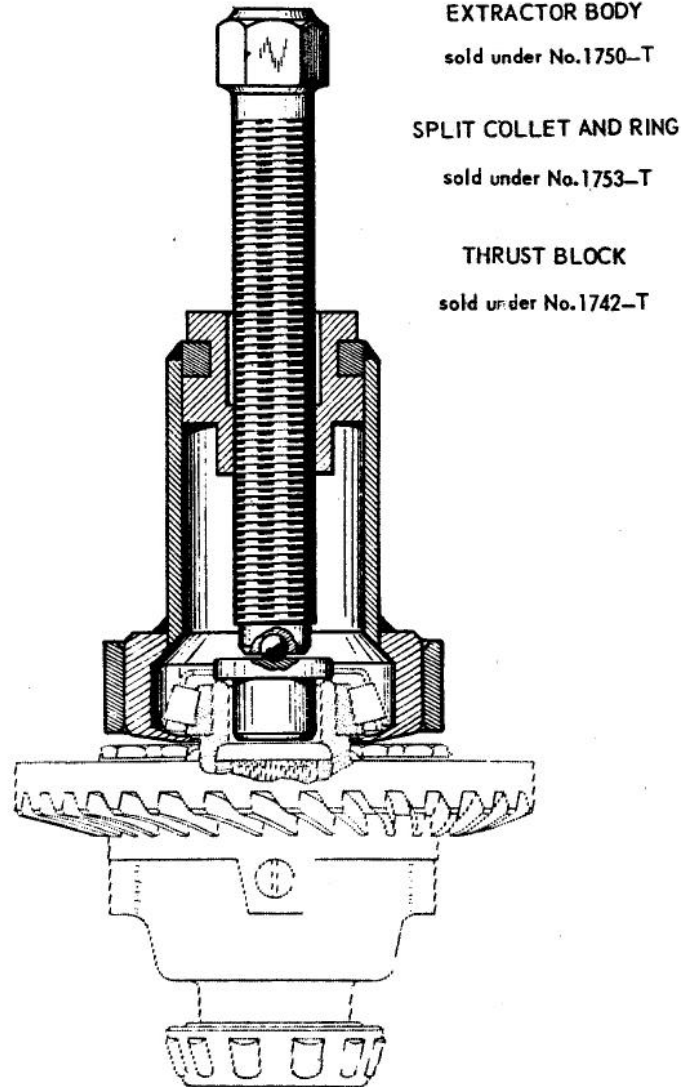
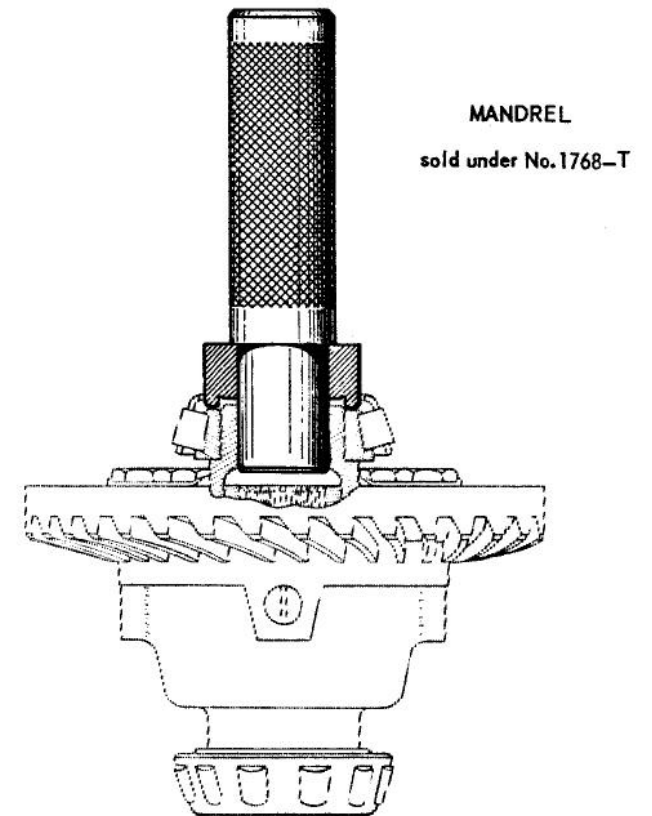

Fig.2 - FITTING BEARING ROULEMENT



STAND FOR GEARBOX FOR USE ON BENCH

STAND MR-3053-130

not sold

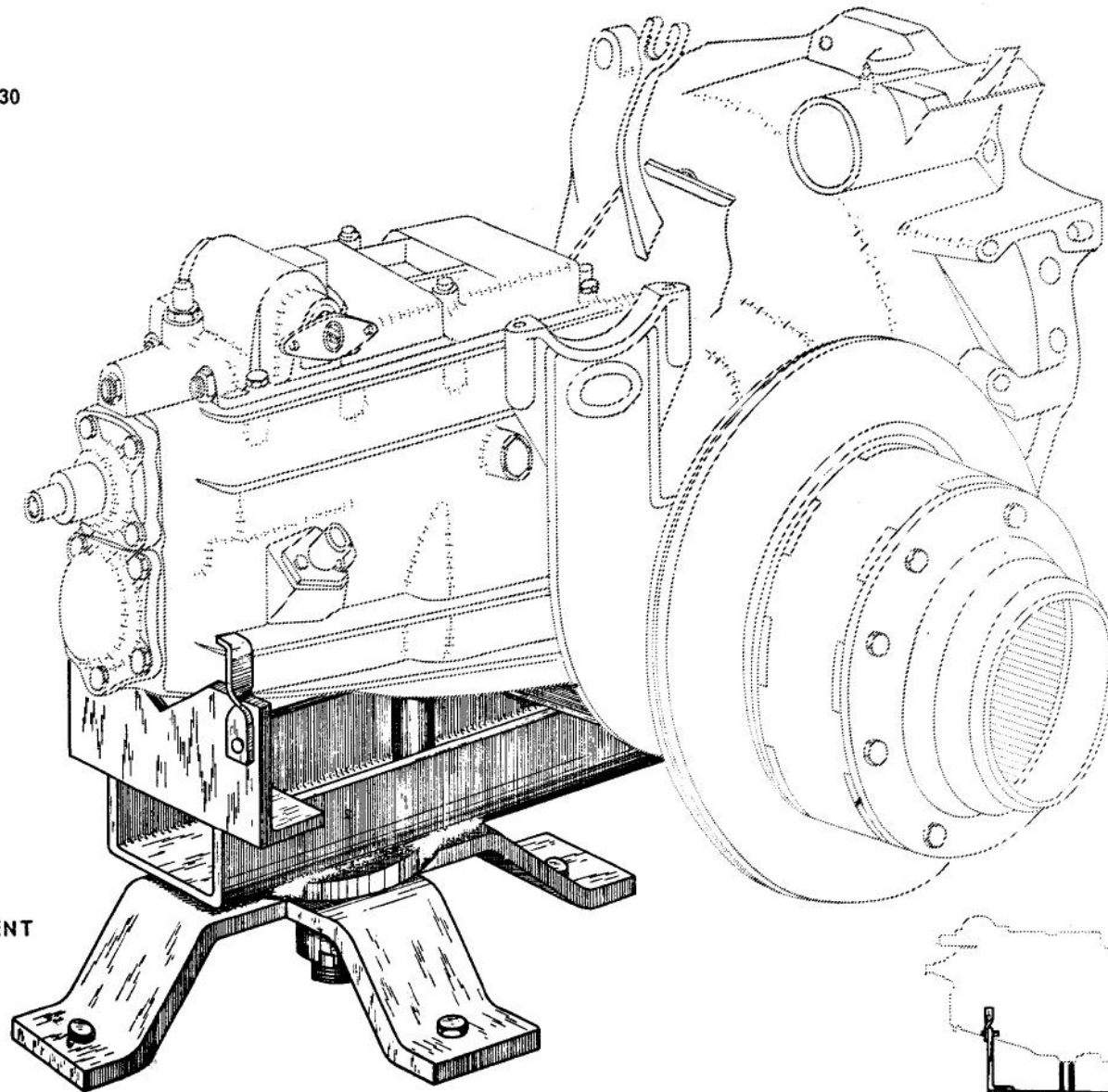

FOR CONSTRUCTIONAL  
DIMENSIONS APPLY TO  
THE SERVICE DEPARTMENT

VARIOUS TOOLS

Fig1 - MANDREL MR-3045

not sold

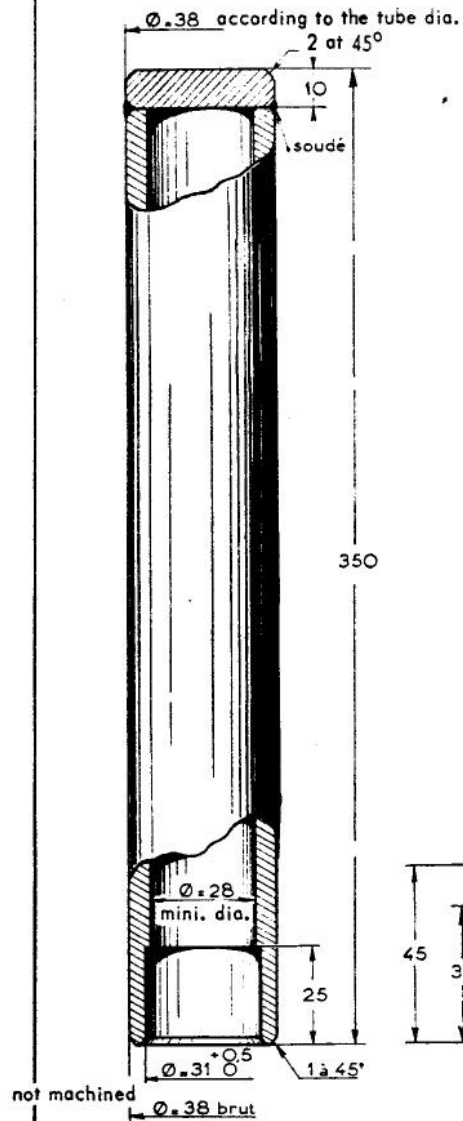

Fig2 - MANDREL MR-3676-30

not sold

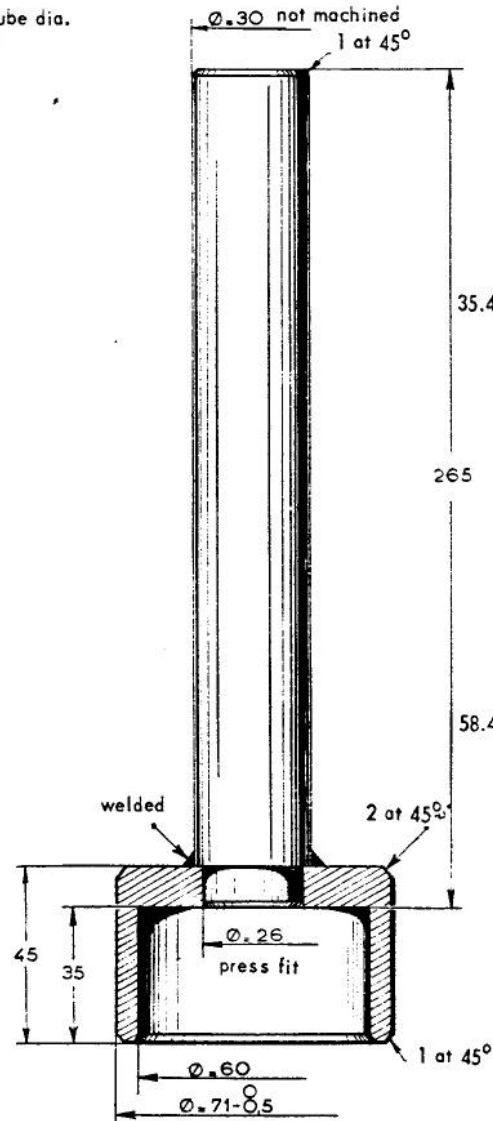

Fig.3 - SPANNER

sold under No.1734-T

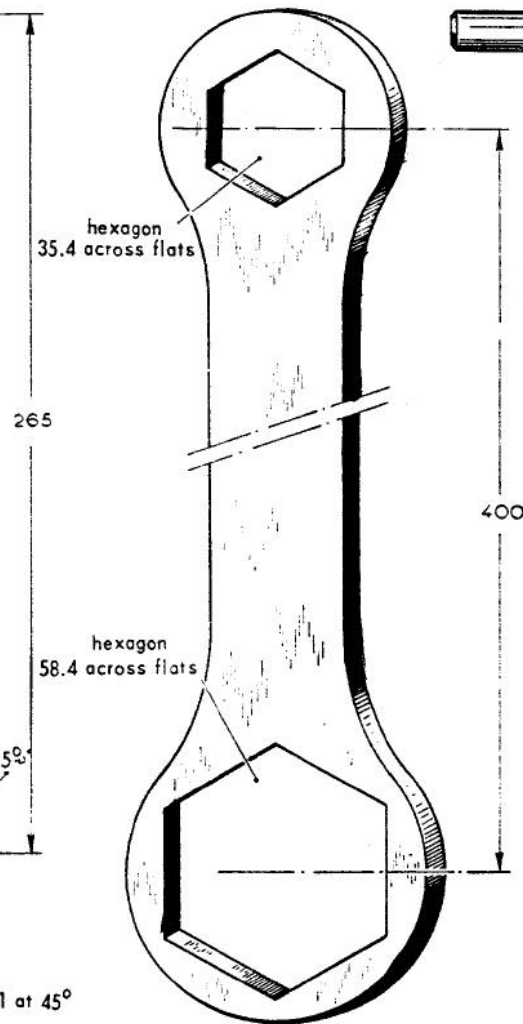
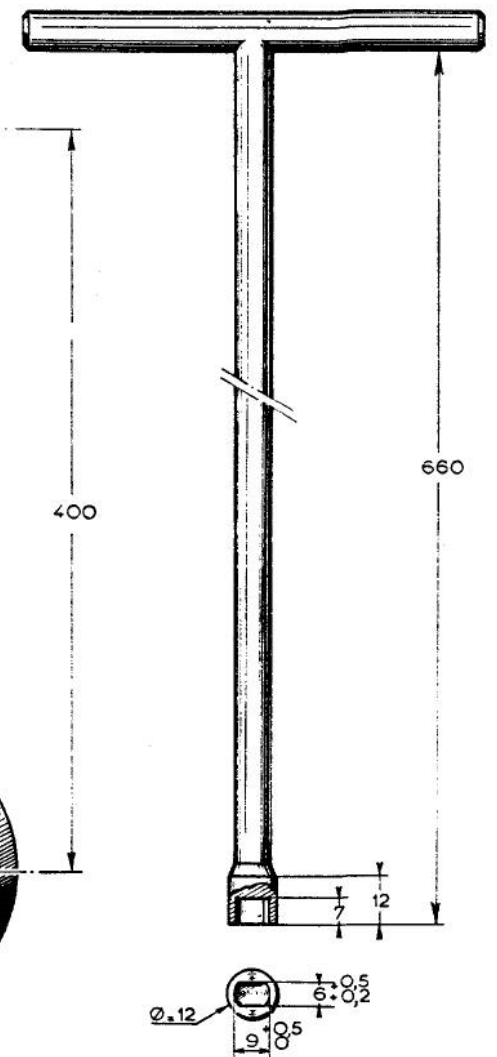

Fig.4 - SPANNER

sold under No.1677-T



VARIOUS TOOLS

Fig1 - MANDREL  
sold under No.1767-T

THE BUSH A CENTRES THE OIL RETAINING WASHER AND THE MANDREL B. ASSURES THE POSITIONING OF THE THRUST BEARING.

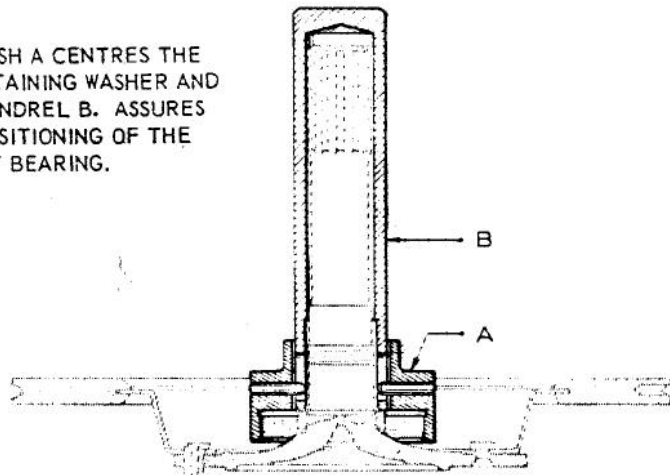

Fig 2 - MANDREL  
sold under No.1772-T

THE BUSH C CENTRES THE SEALING JOINT AND THE MANDREL D ASSURES THE POSITIONING OF THE JOINT.

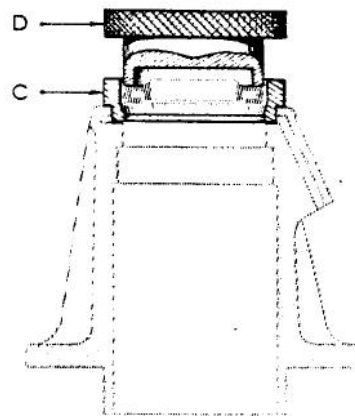

Fig.3 - SPANNER  
sold under No.1771-T

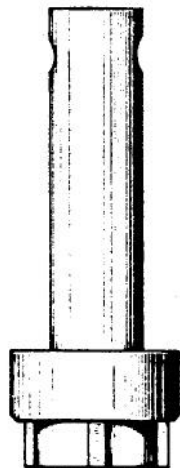
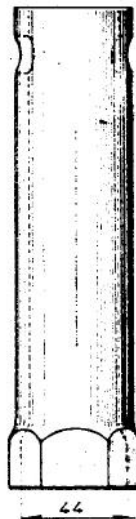
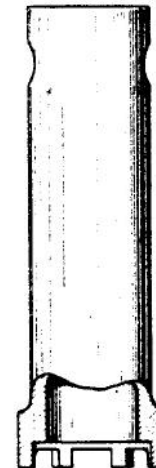

Fig.4 - SPANNER  
sold under No.1770-T



across flats

Fig.5 - SPANNER  
sold under No.1640-T



ASSEMBLY OF THE LEVERS OPERATING THE SELECTOR SHAFTS

Fig 1

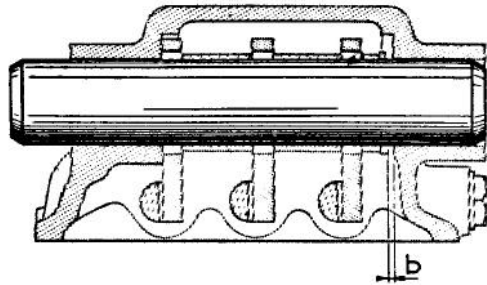

Fig 3

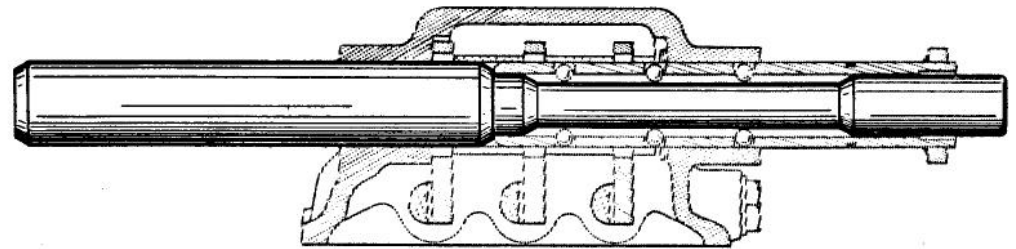

Fig 2

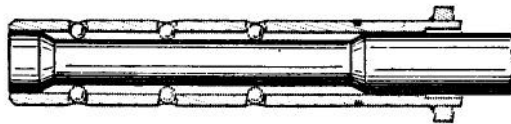

Fig 4

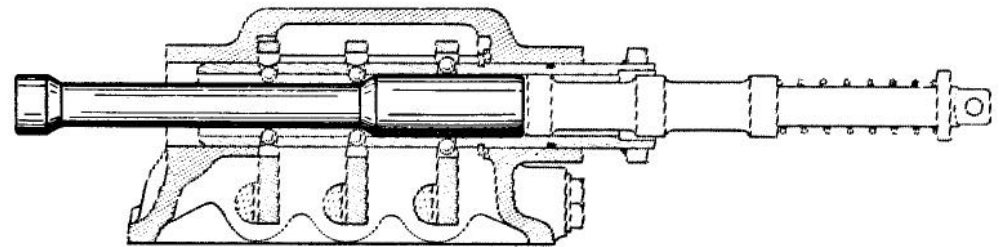
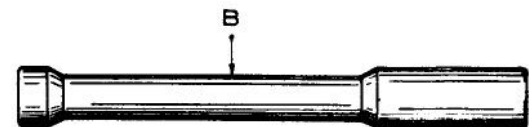
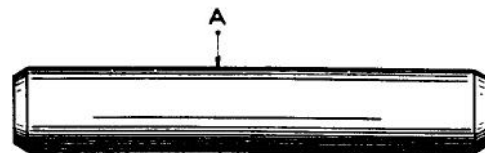
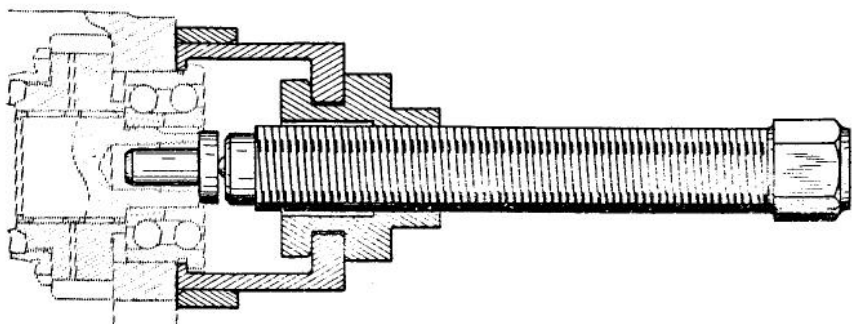

Fig.5 - MANDREL  
sold under No.1793-T



VARIOUS TOOLS

Fig.1 — EXTRACTOR FOR MAIN SHAFT FRONT BEARING



EXTRACTOR BODY  
sold under No.1750-T

SPLIT COLLAR AND PRESSURE PAD  
sold under No.1738-T

Fig.2 — SPANNER MR-3691-80

not sold

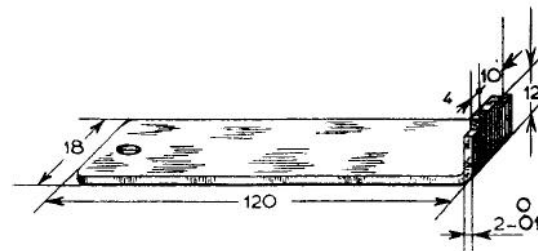

Fig.5 SPANNER Sold under No. 1705-T

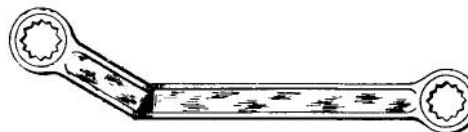

Fig.3 — EXTRACTOR FOR BEVEL PINION SHAFT FRONT BEARING

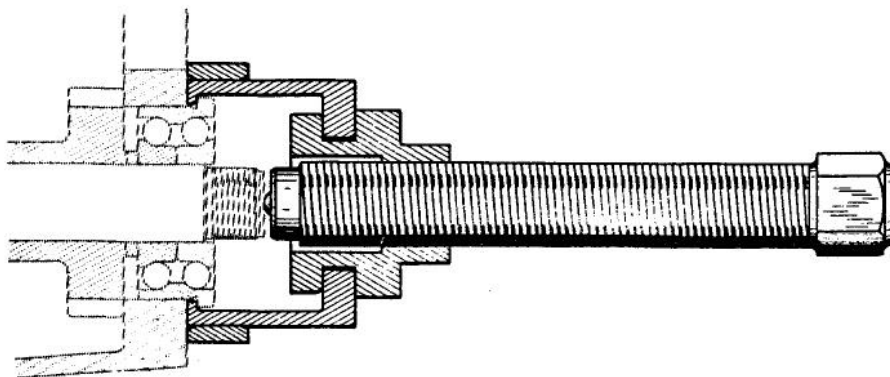
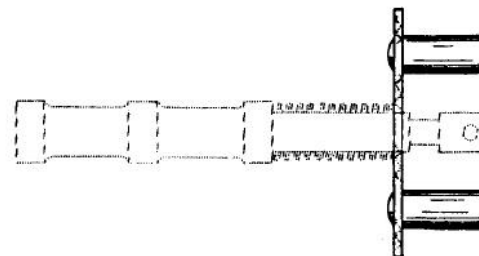

Fig.4 — SPRING COMPRESSOR

sold under No.1792-T



# ALIGNMENT OF THE PULLEYS

Fig.1

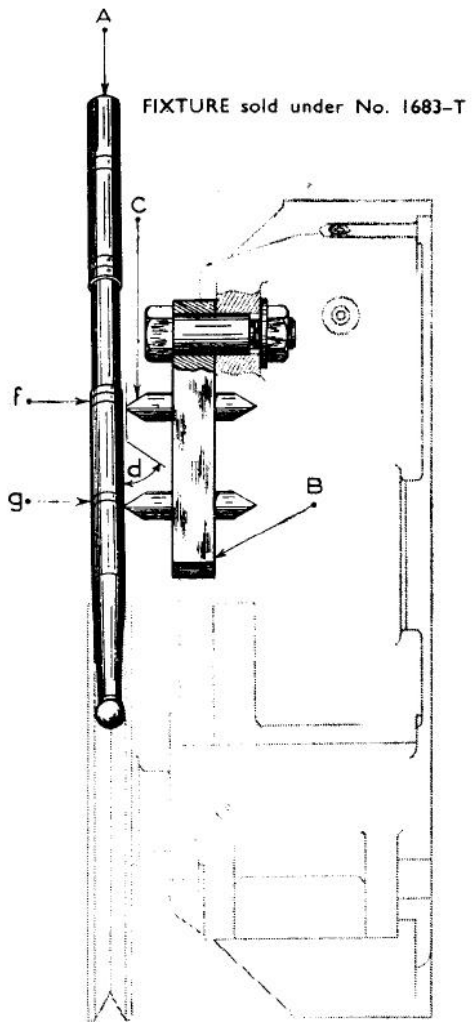

Checking the position of the Driving Pulley

Fig.2

Checking the position of the Water Pump Pulley

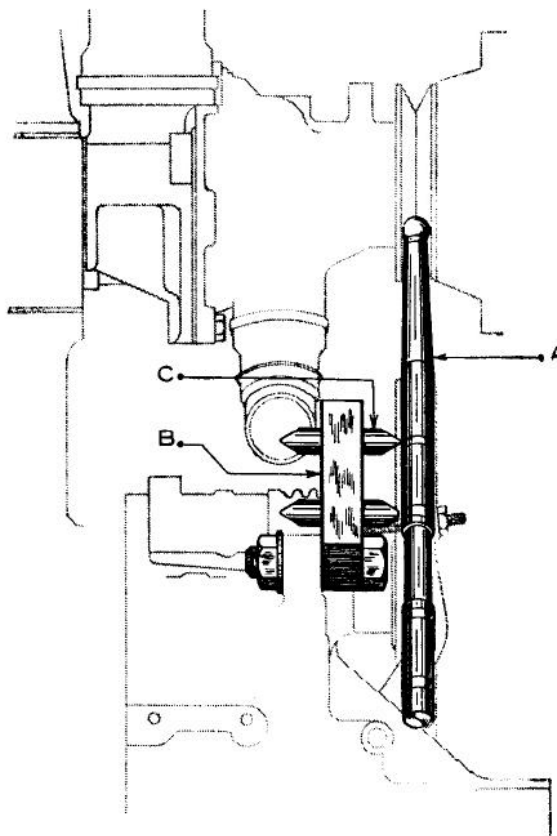
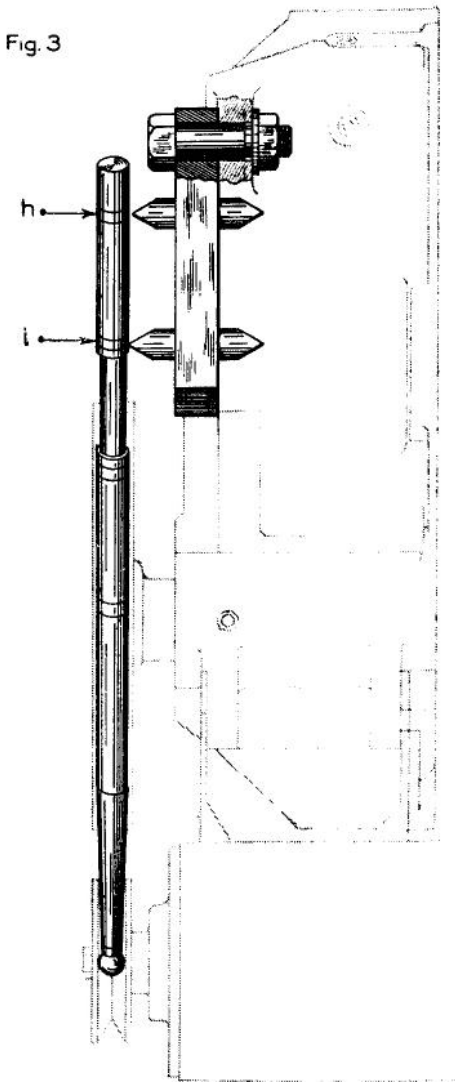

Fig. 4



Fig.3



Checking the position of the Dynamo Pulley



GEAR CHANGE CONTROL

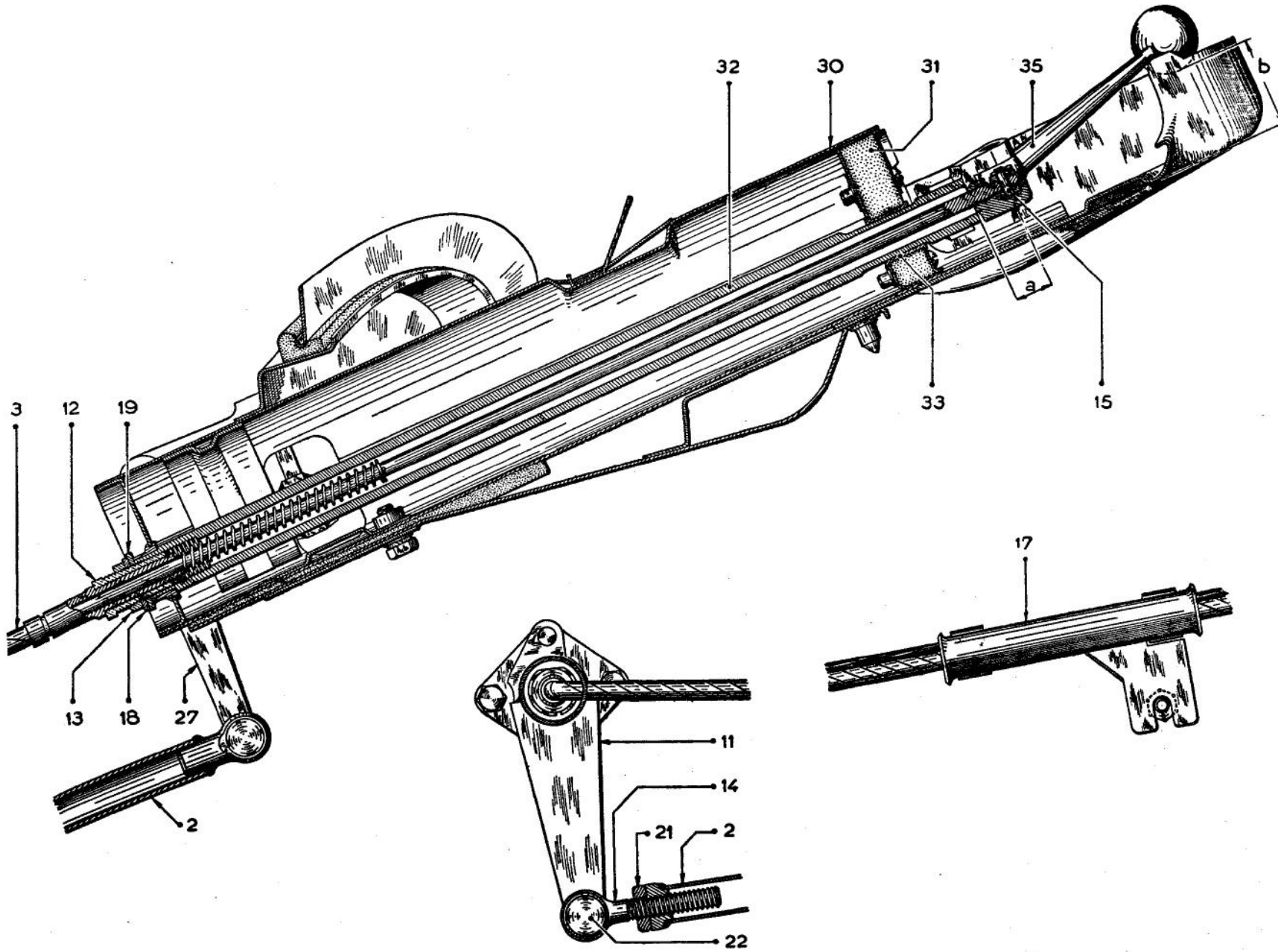

GEAR CHANGE CONTROL

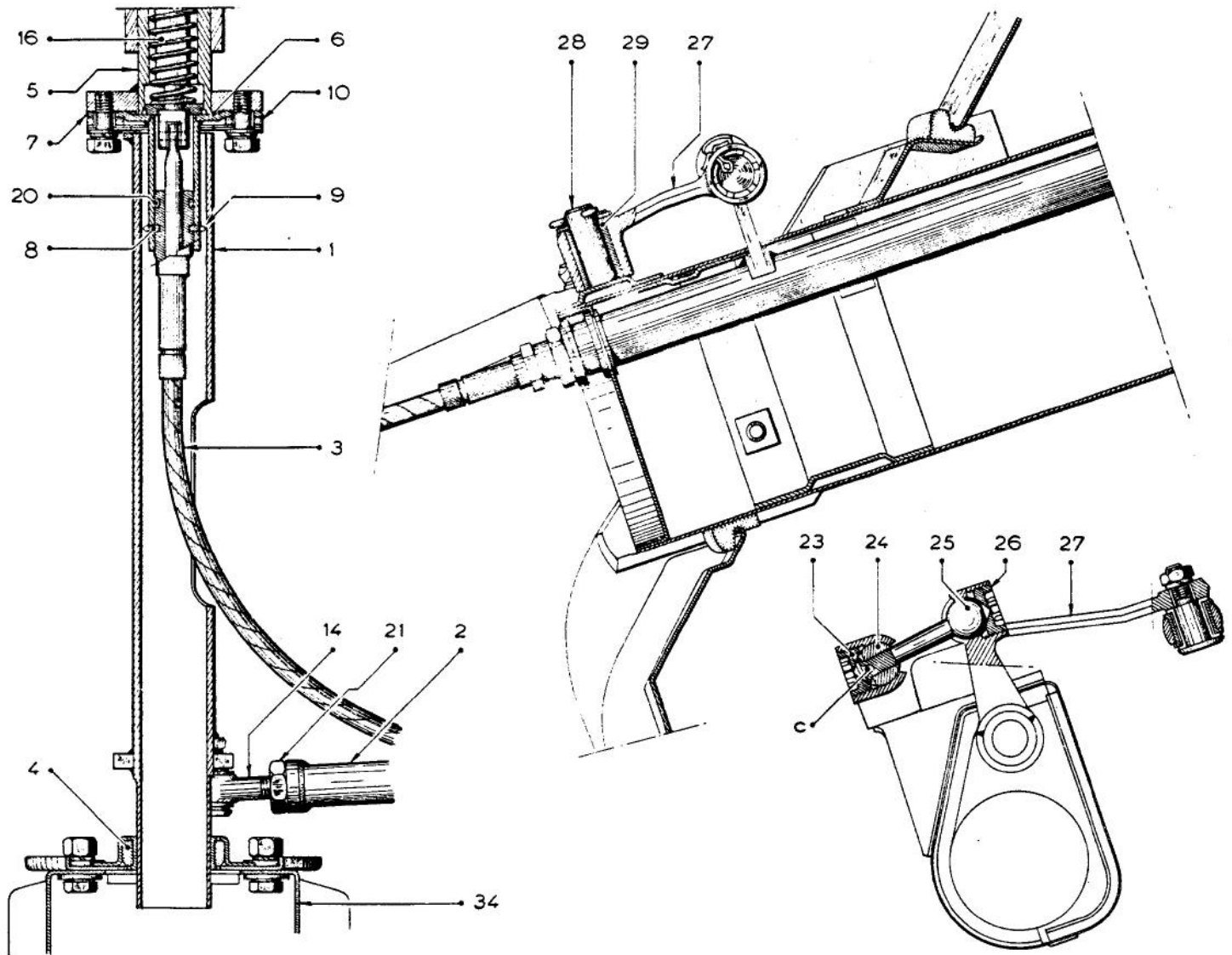

VARIOUS TOOLS

Fig. 1 - SPANNER  
sold under No.2431-T

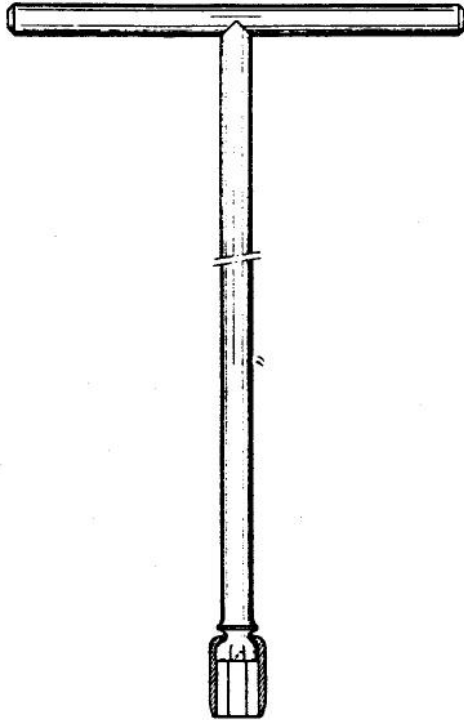

Fig. 2 - CLAMP  
sold under No.2427-T

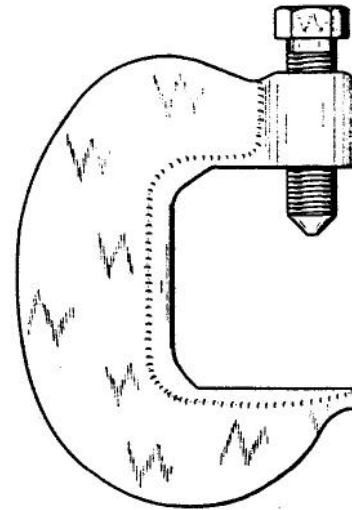

Fig. 3 - SPANNER  
sold under No.2219-T

Spanner 2219-T a =  $9^{+0.2}_{0}$

Spanner 2220-T a =  $15^{+0.3}_{0.1}$

Spanner 2221-T a =  $10^{+0.2}_{0}$

Spanner 2222-T a =  $13^{+0.3}_{0.1}$



Fig. 4 - SPANNER MR-3691-60  
not sold

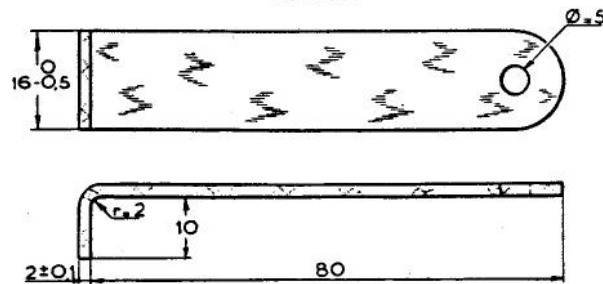

OPERATIONS  
ID 372-1  
ID 410-3  
ID 413-1

FRONT AXLE

ID 19

62

SECTIONS

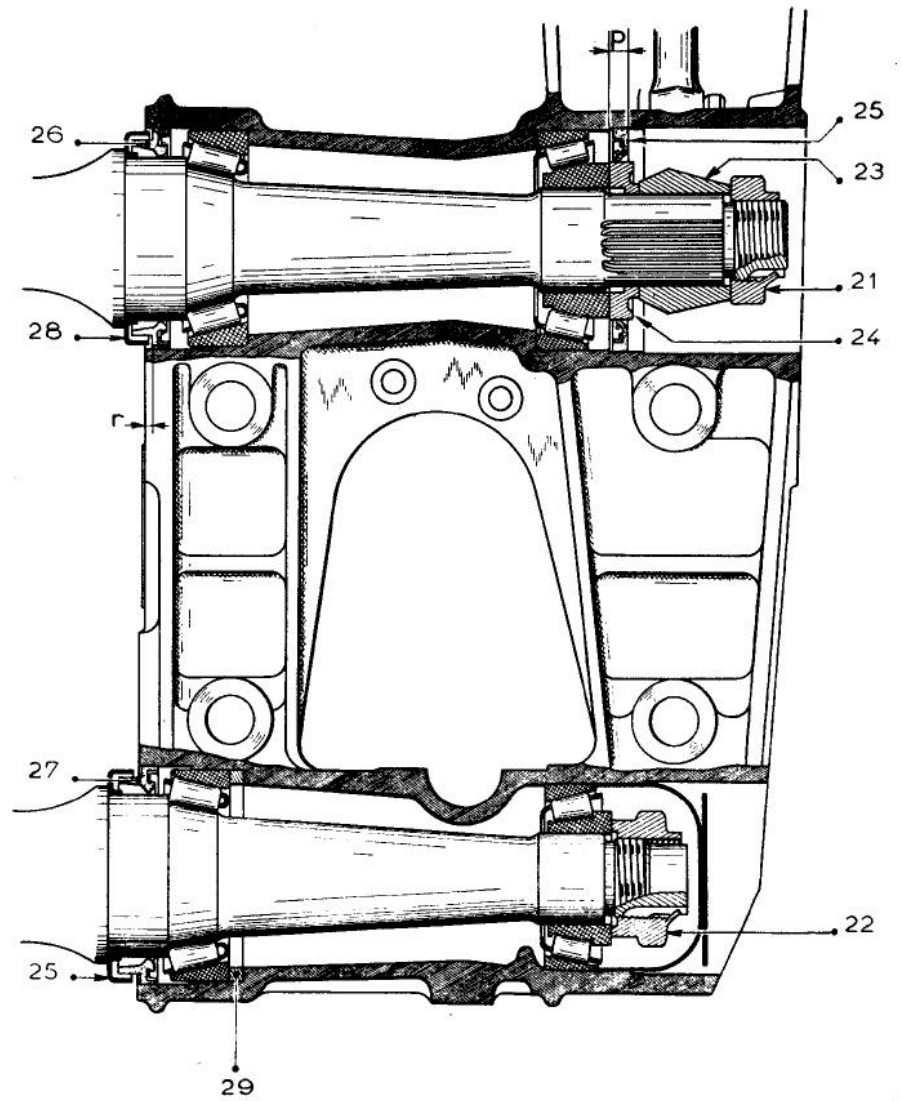
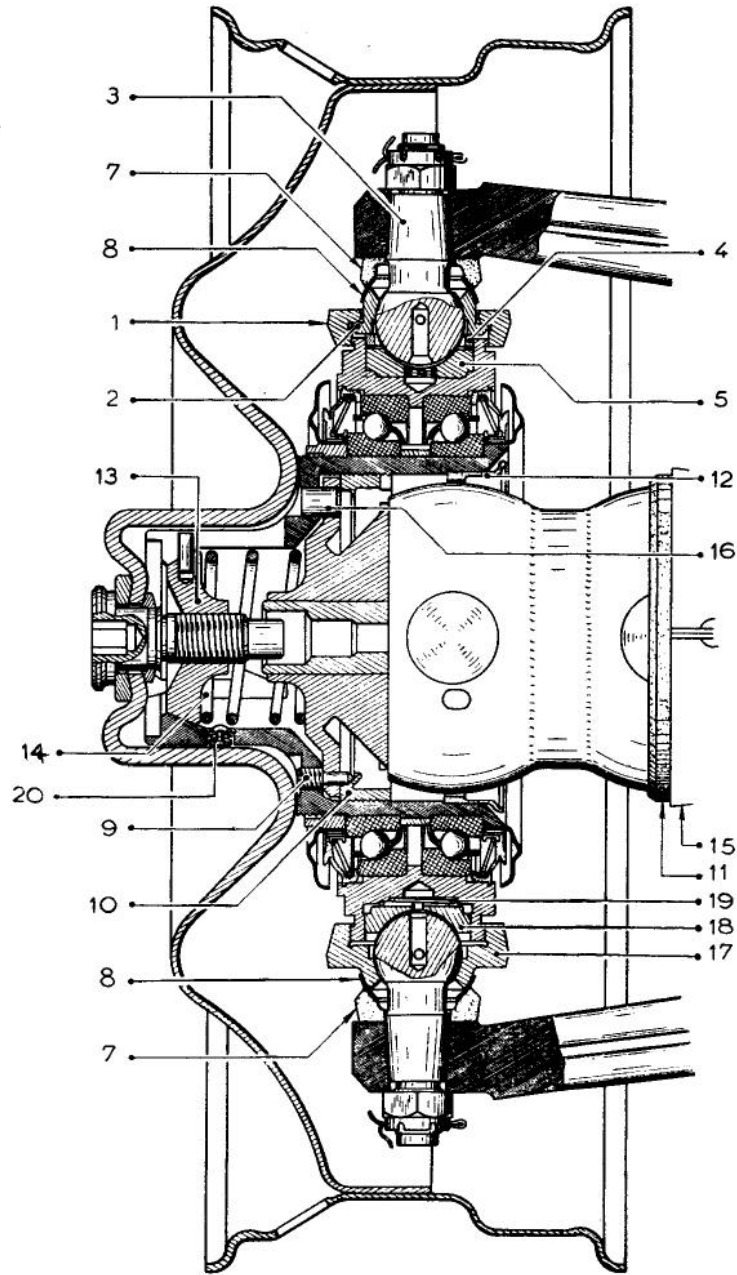

SECTION OF THE UPPER BALL JOINTS

Fig. 1

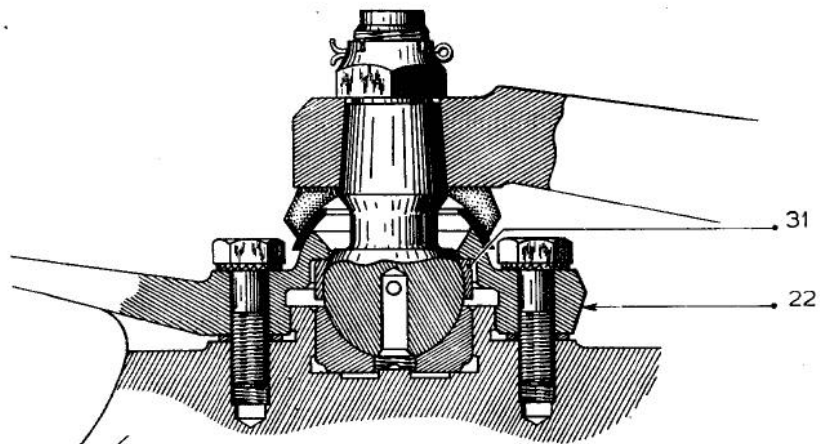

Fig. 2

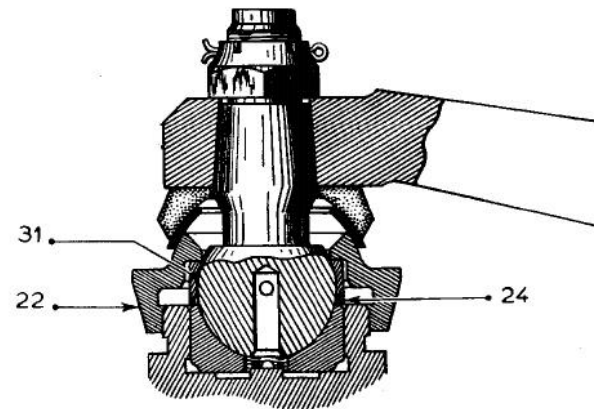
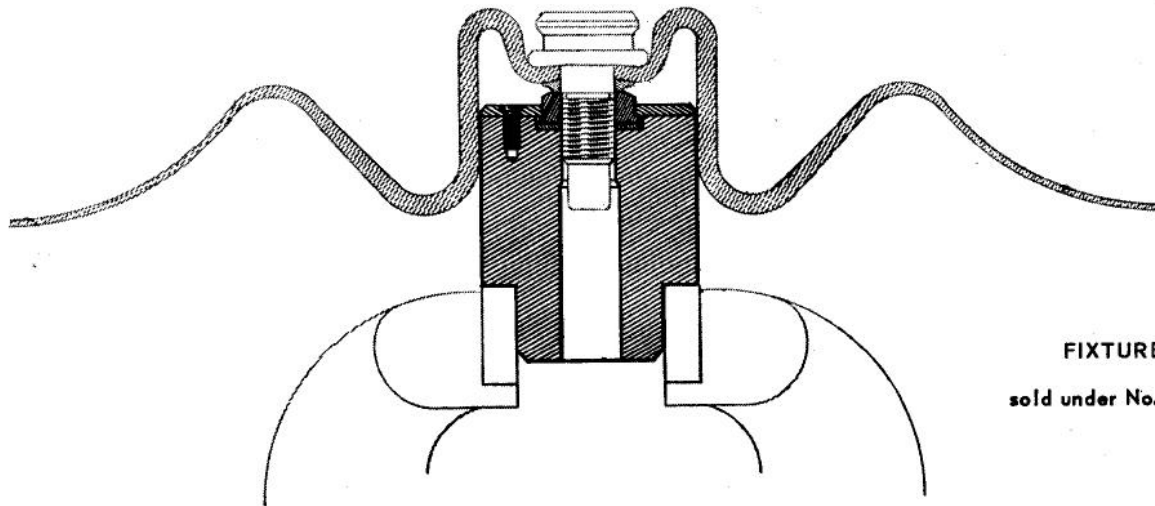

Fig. 3 — ASSEMBLY OF THE WHEEL LOCKING SCREW



FIXTURE

sold under No. 1868-T

VARIOUS TOOLS

Fig. 1 - EXTRACTOR

sold under No. 1856-T

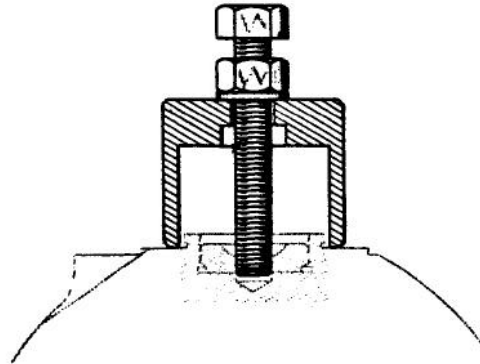

Fig. 2 - FIXTURE

sold under No. 1857-T

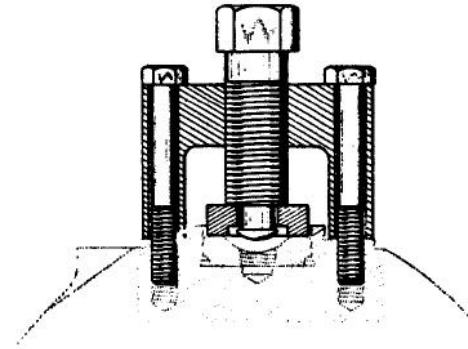
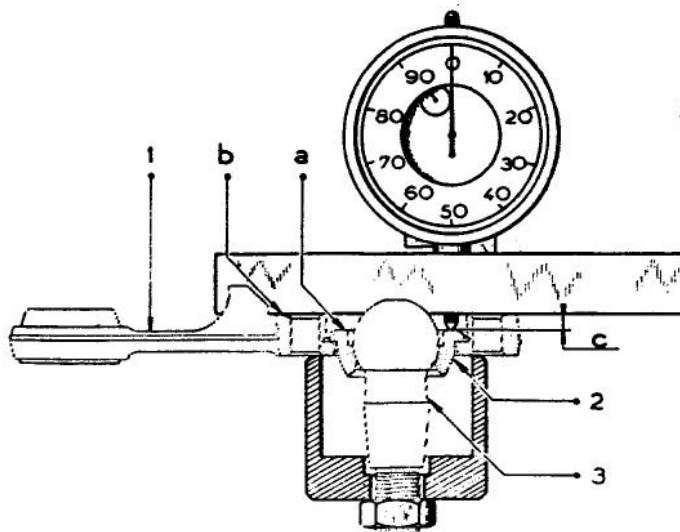

Fig. 3 - ADJUSTING THE UPPER BALL JOINT

SETTING DIAL GAUGE  
USING THE BODY OF EXTRACTOR 1856-T



MEASURING THE THICKNESS OF ADJUSTING WASHER

DIAL GAUGE  
sold under No. 2437-T  
STRAIGHT EDGE MR. 3377  
not sold

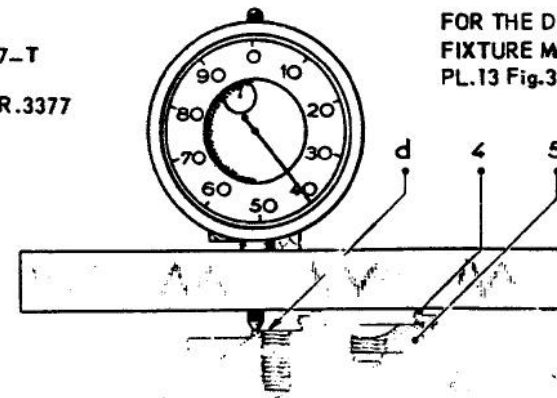

FOR THE DIMENSIONS OF  
FIXTURE MR. 3377. SEE  
PL. 13 Fig. 3

VARIOUS TOOLS

Fig. 1 - ADJUSTING FIXTURE

sold under No.1867-T

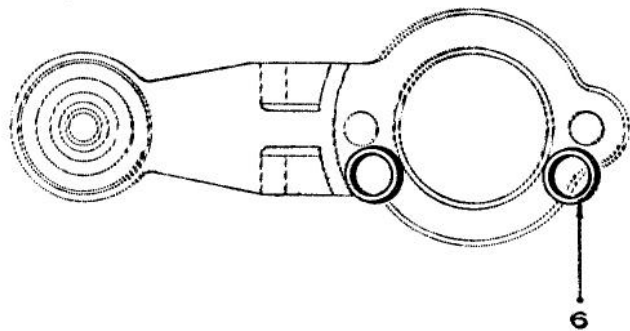

Fig. 2 - EXTRACTOR

sold under No.1964-T

Fig. 3 - EXTRACTOR AND PRESSURE PAD Fig. 4 - SPANNER MR 3691-40 Fig. 5 - SPANNER

sold under No.1864-T

not sold

sold under No.2285-T

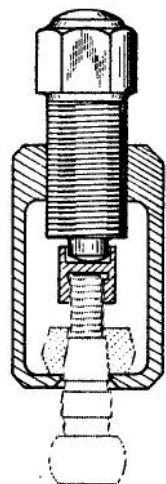
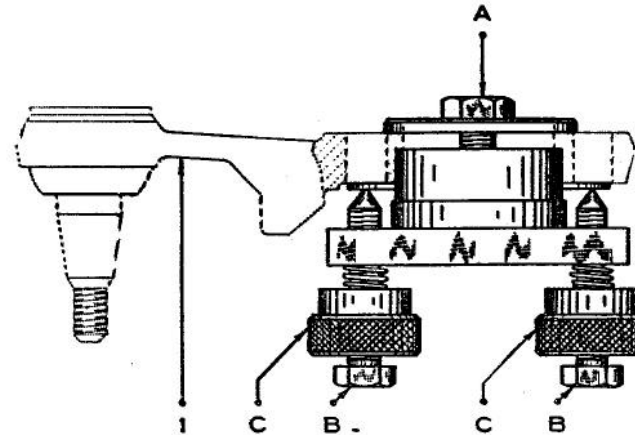

PRESSURE PAD  
sold under No.1968-T

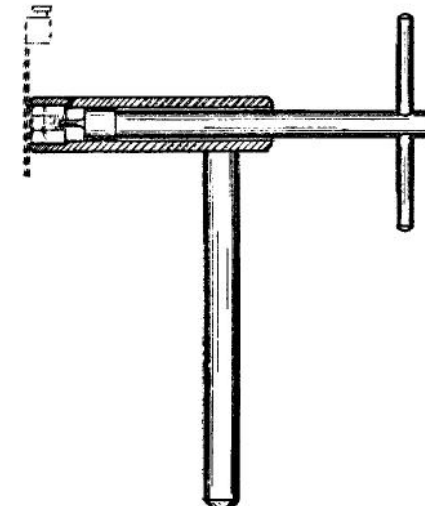
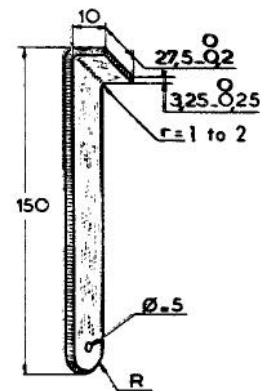
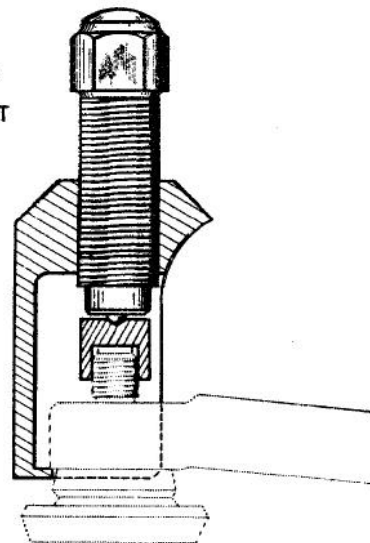

SUPPORT FOR HALF-AXLE

Fig. 1 - SUPPORT MR-3053-120

not sold

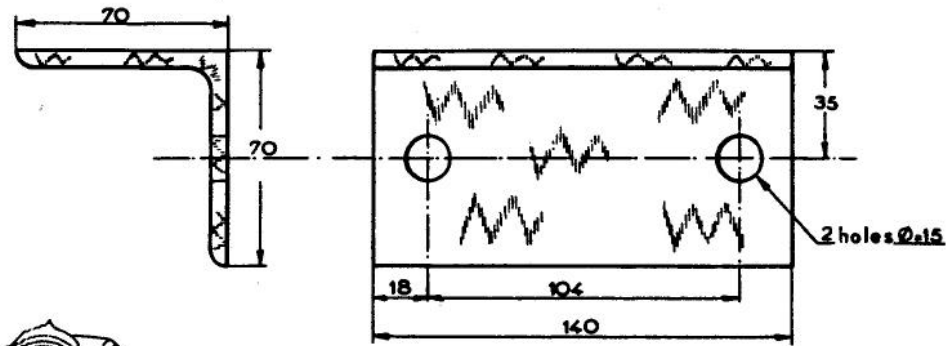
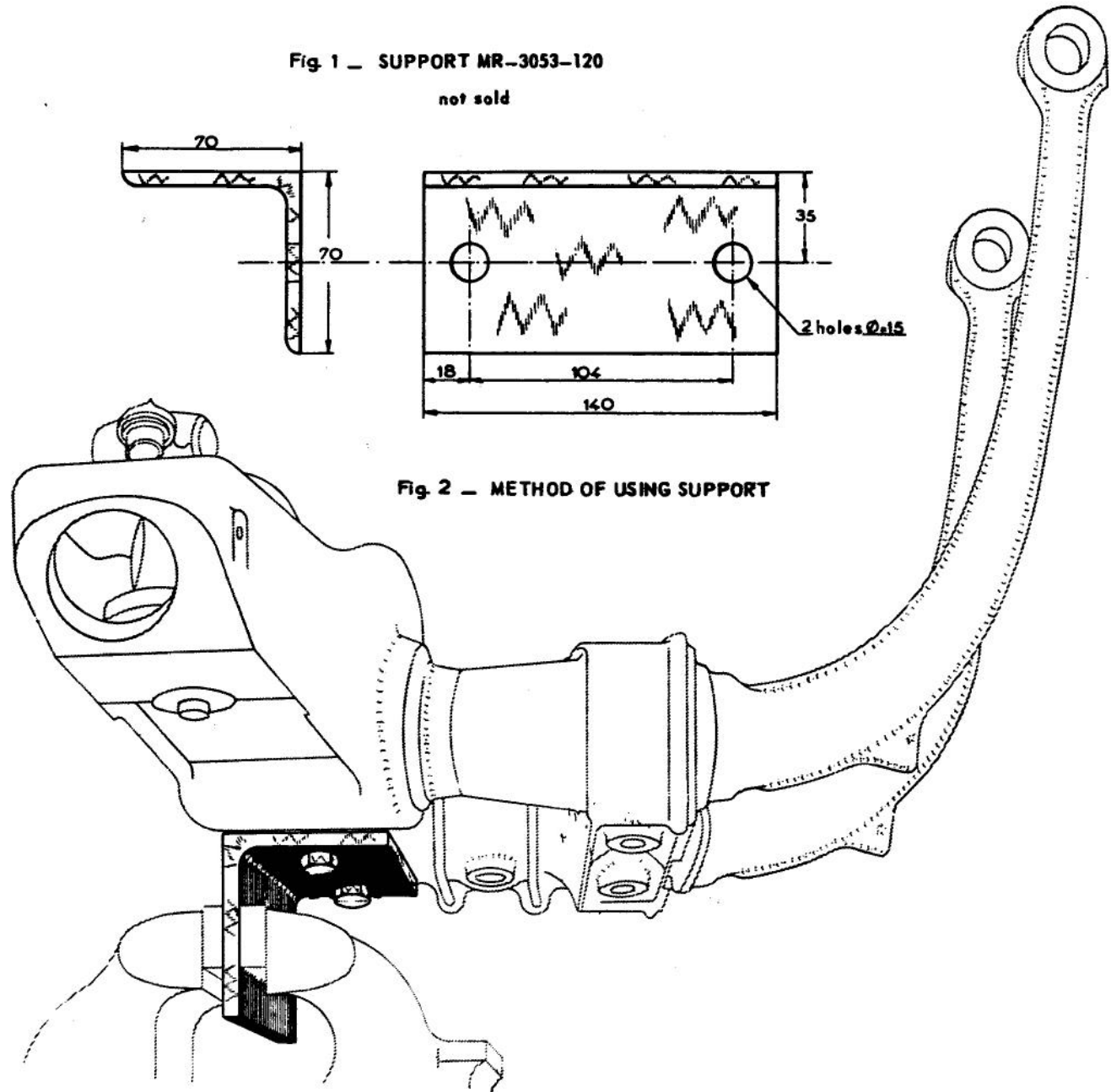

Fig. 2 - METHOD OF USING SUPPORT





VARIOUS TOOLS

Fig. 1 SPANNER

Sold under No. 1921-T

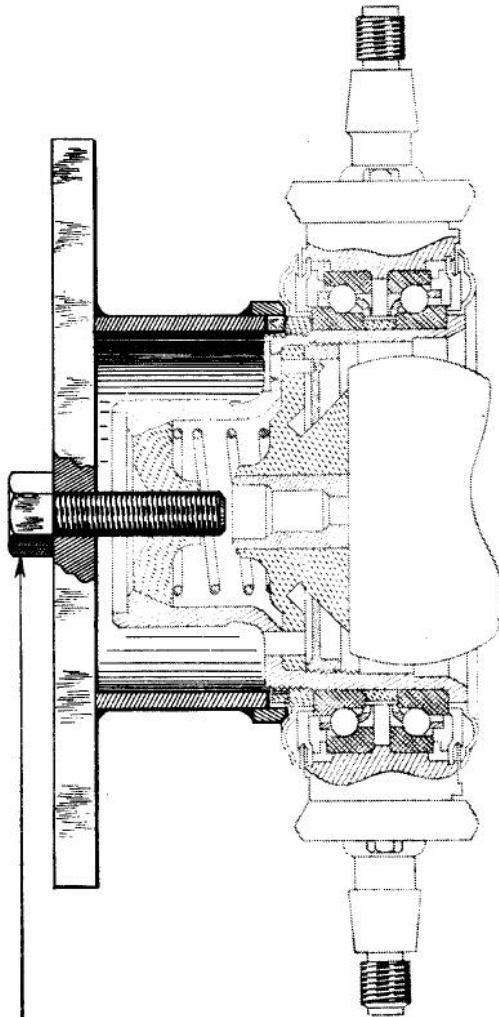

Screw dia. J8 x 150 length 60

Fig 2

SPANNER

Sold under No. 1920-T

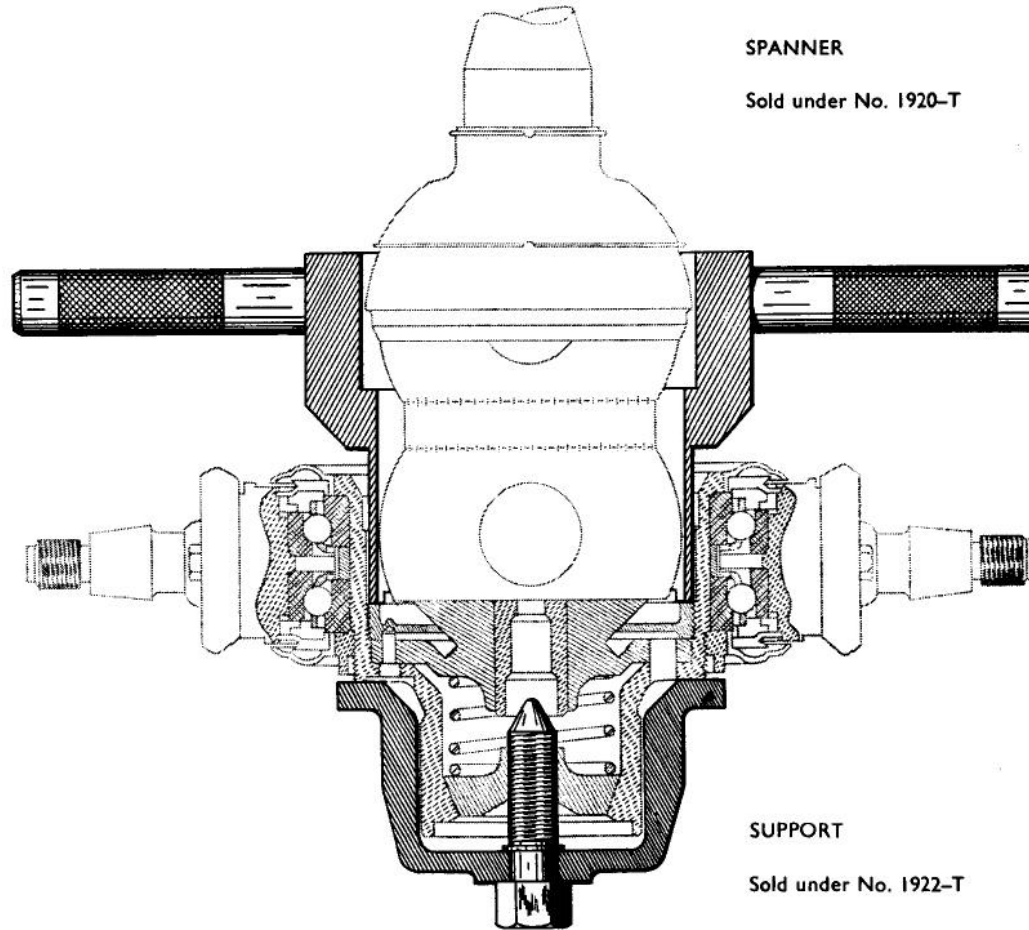

SUPPORT

Sold under No. 1922-T

ASSEMBLY OF THE SEALS

Fig. 1 — METHOD OF USING THE RING AND DISC MR-3676-140

Fig. 2 — METHOD OF USING THE MANDREL MR-3676-150

Fig. 3 — MANDREL MR-3676-156

not sold

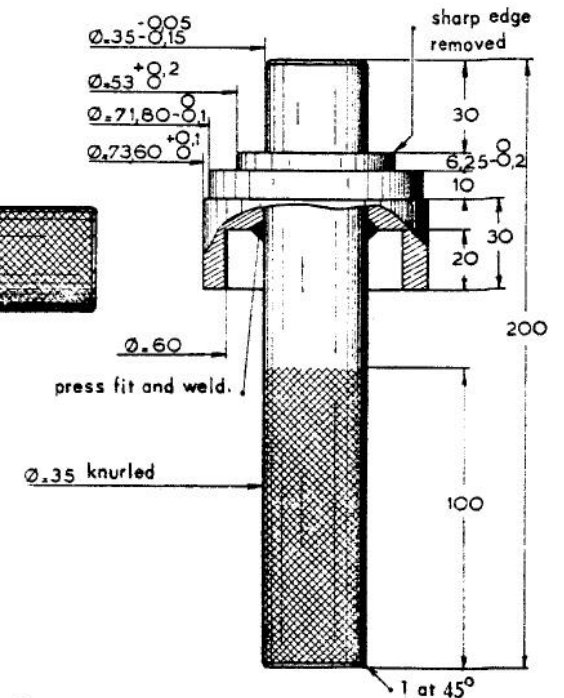
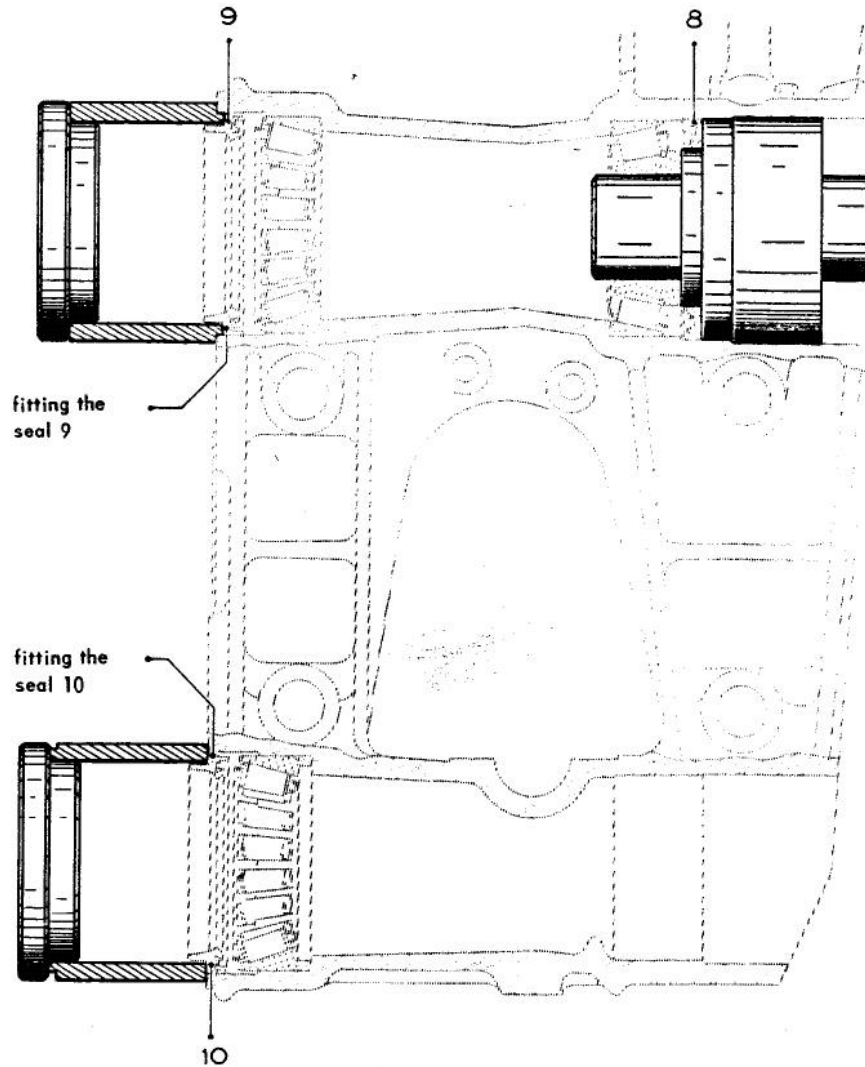
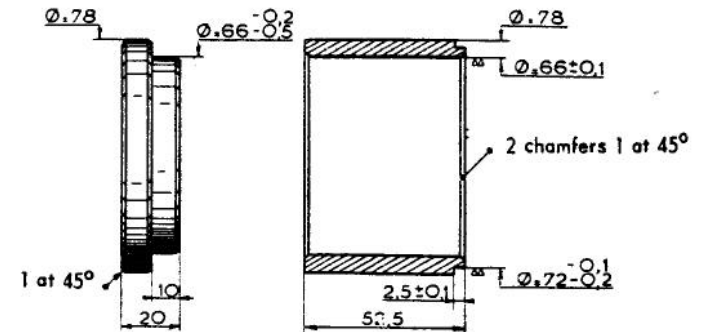

Fig. 4 — RING AND DISC MR-3676-140

not sold



## ASSEMBLY OF THE DRIVE SHAFT DUST COVER

Fig. 1

Fig. 2

## TAPER FITTING FOR POSITIONING DUST COVER

sold under No. 1930-T

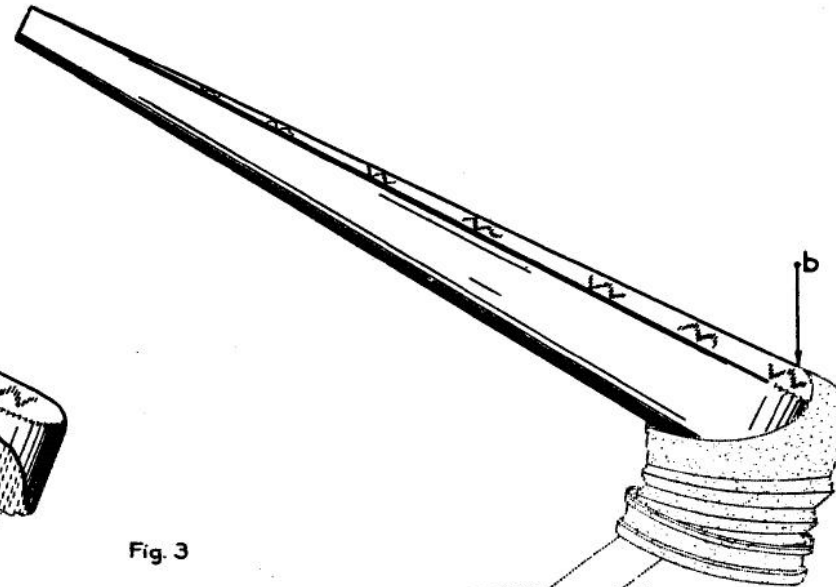
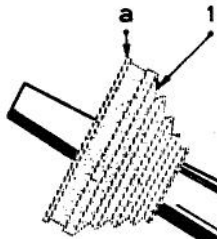
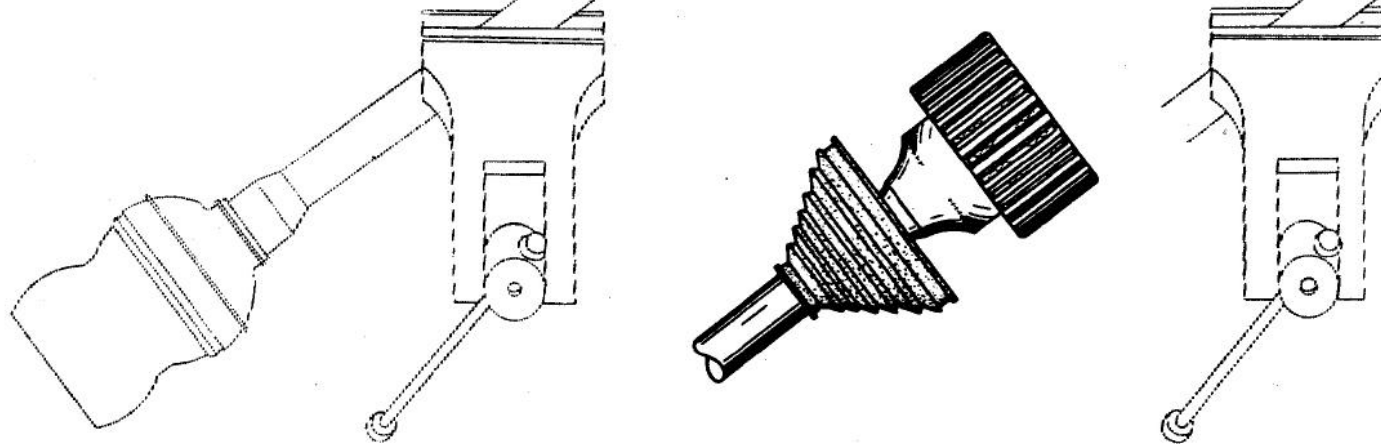

Fig. 3

- 1st GREASE THE TAPER FITTING
- 2nd PUT THE DUST COVER 1 ON THE TAPER AS SHOWN (Fig. 1)
- 3rd GRASP THE DUST COVER BY THE LARGE DIAMETER AT 'a'. PULL FIRMLY OVER THE END 'b'.
- 4th REMOVE THE TAPER FITTING. TURN THE DUST COVER BACK INTO ITS ORIGINAL SHAPE AS SHOWN (Fig. 3)



## ADJUSTMENT OF THE CASTOR ANGLE

Fig. 1

FIX THE RODS A AND B ON THE AXLE ARMS BY USING THE SCREW C.

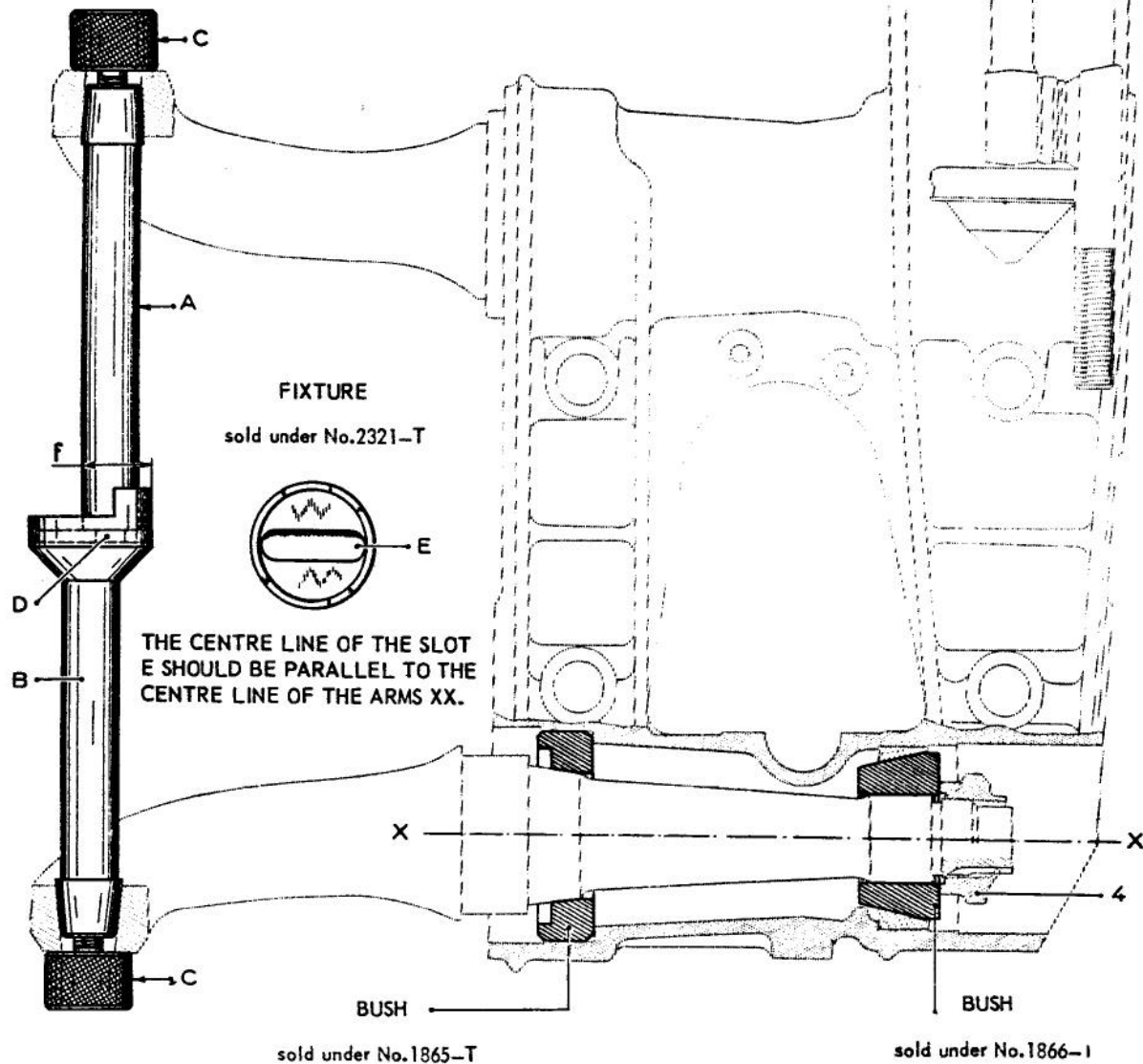

BRING THE ROD A INTO CONTACT WITH THE CUP ON THE ROD B. THE HEAD D ON THE ROD A ENGAGED IN THE SLOT E ON THE ROD B.

THE SETTING IS CORRECT WHEN THE DIMENSION F IS BETWEEN 24.75 AND 25.25 mm.

Fig. 2

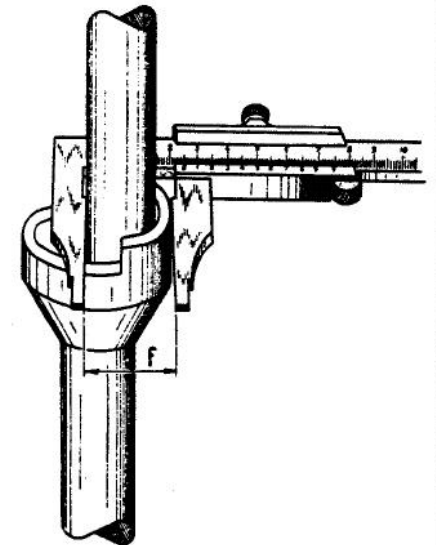

NOTE: THE DIMENSION F MUST BE MEASURED PARALLEL TO THE CENTRE LINE OF THE ARMS. TO ENSURE THIS, ROCK THE CALIPER GAUGE SLIGHTLY, UP AND DOWN. THE DIMENSION F IS THE SMALLEST READING ON THE VERNIER.

OPERATIONS

ID 420-1

ID 420-3

ID 420-4

ID 451-4

REAR AXLE

ID19

70

SECTION OF HUB

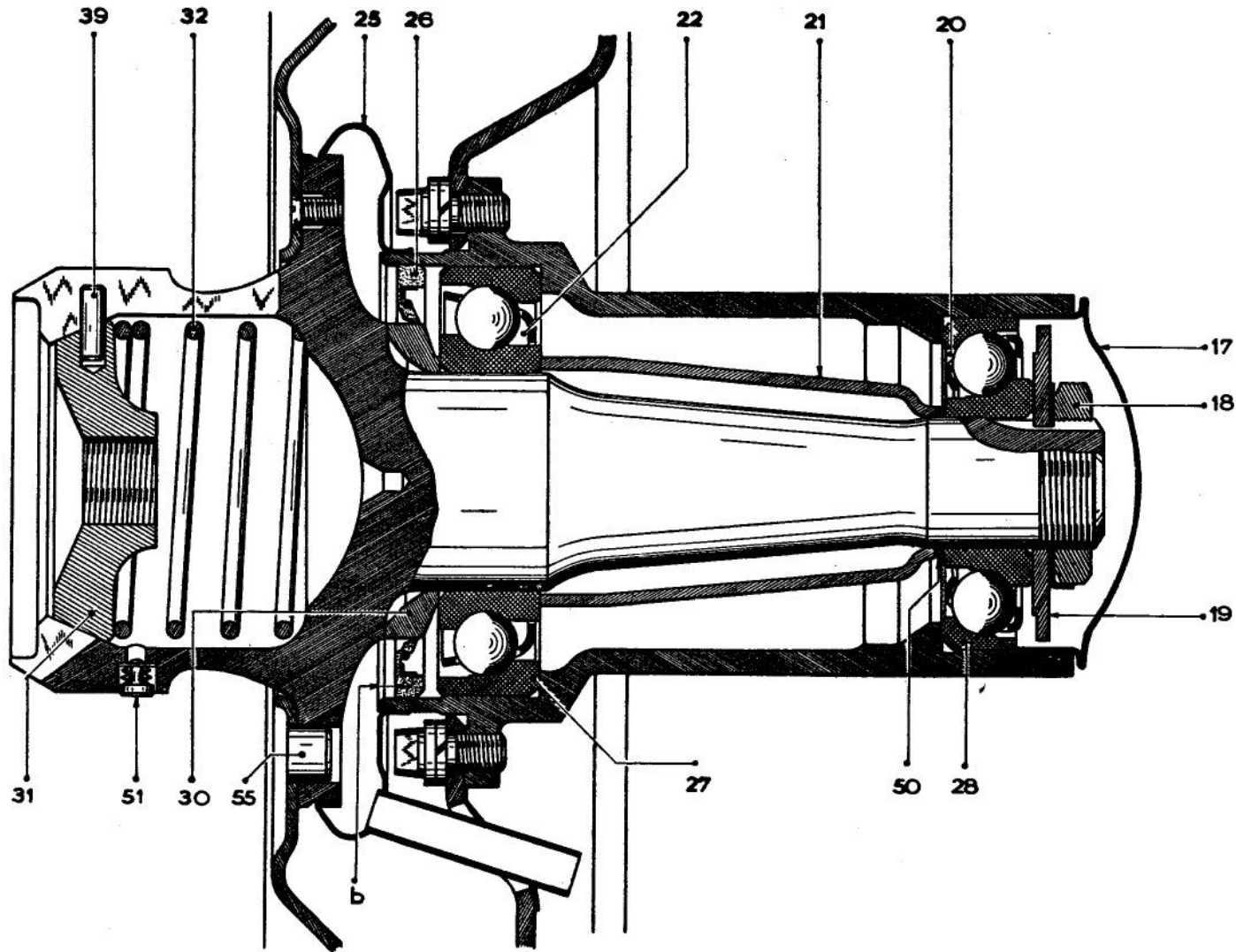

ARM PIVOT BEARING

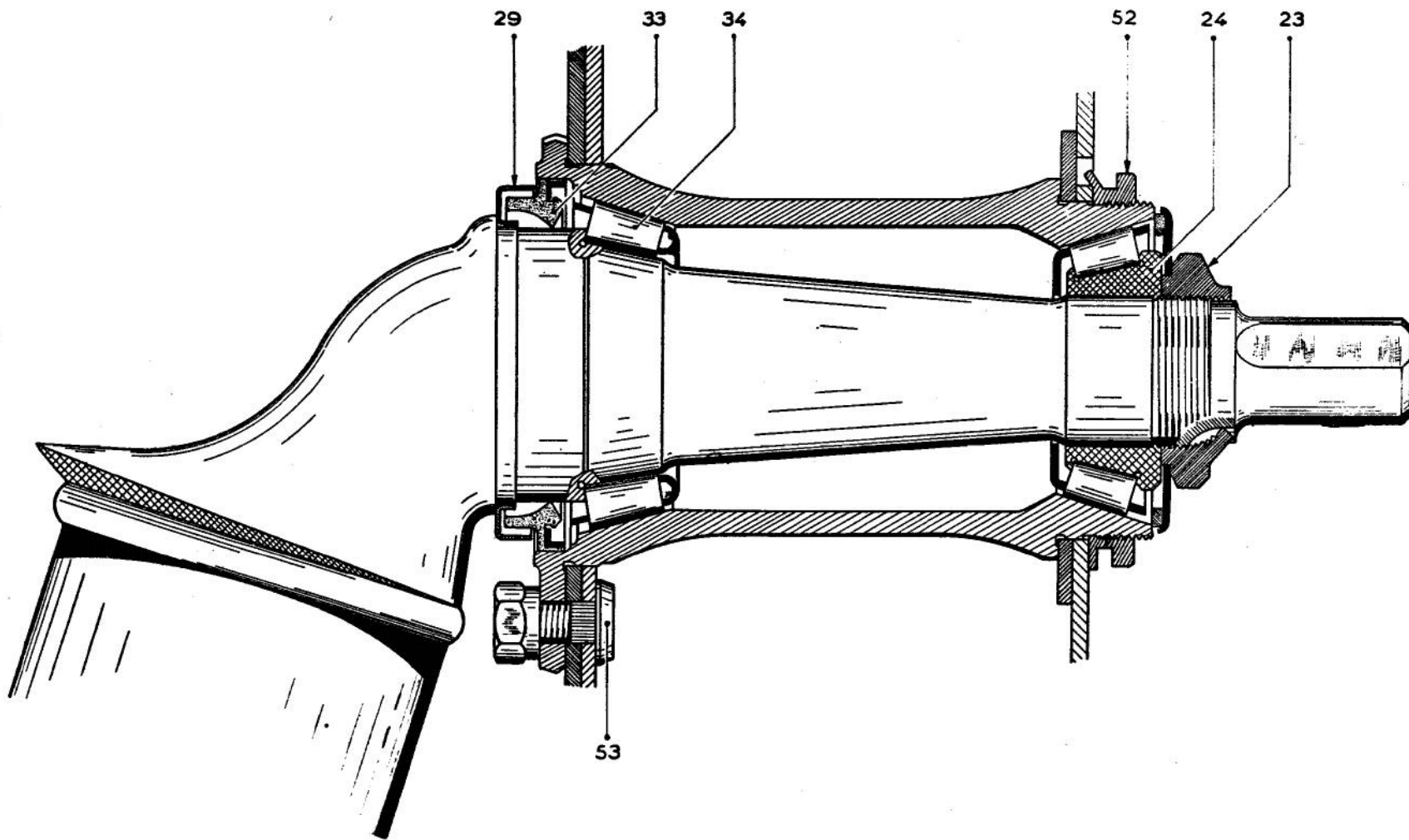

METHOD OF SECURING THE ARM PIVOT BEARING

Fig. 1 — SPANNER

sold under No.1757-T

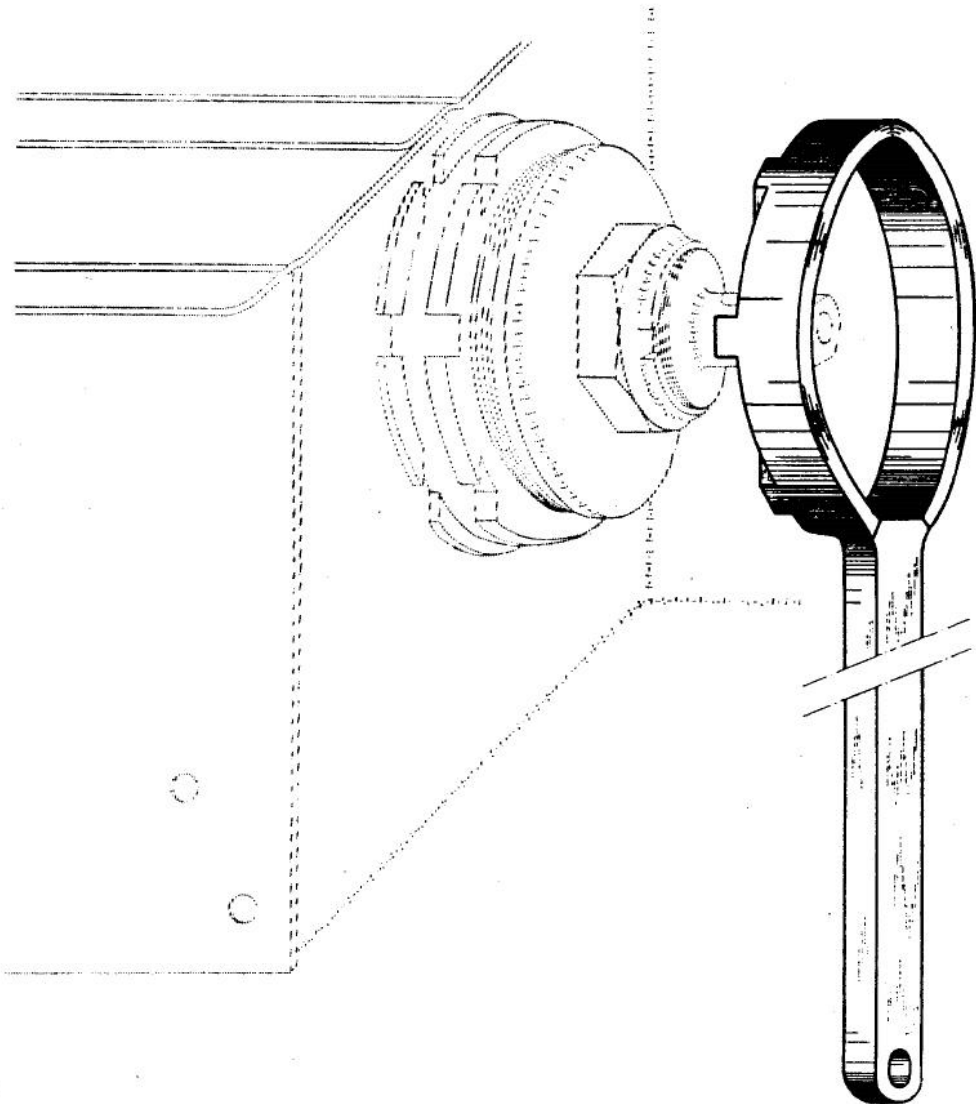
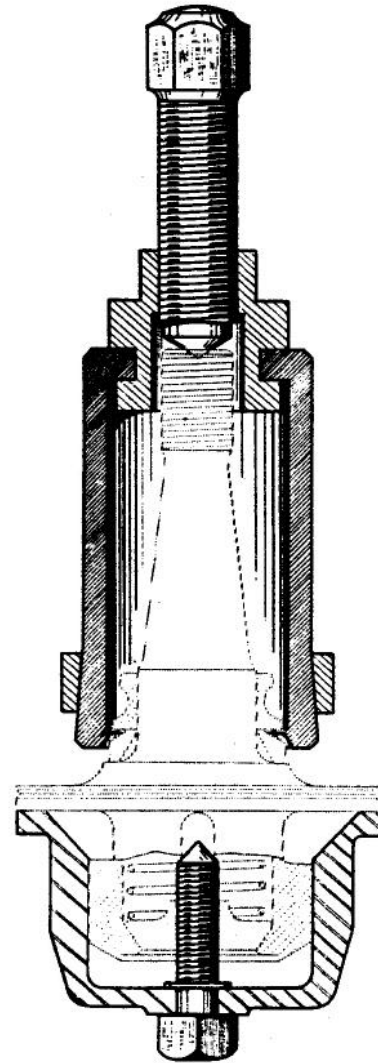

Fig. 2 — EXTRACTOR

sold under No.2020-T



SUPPORT

sold under No.1922-T

## HOLDING THE ARM IN A VICE

Fig. 1 - METHOD

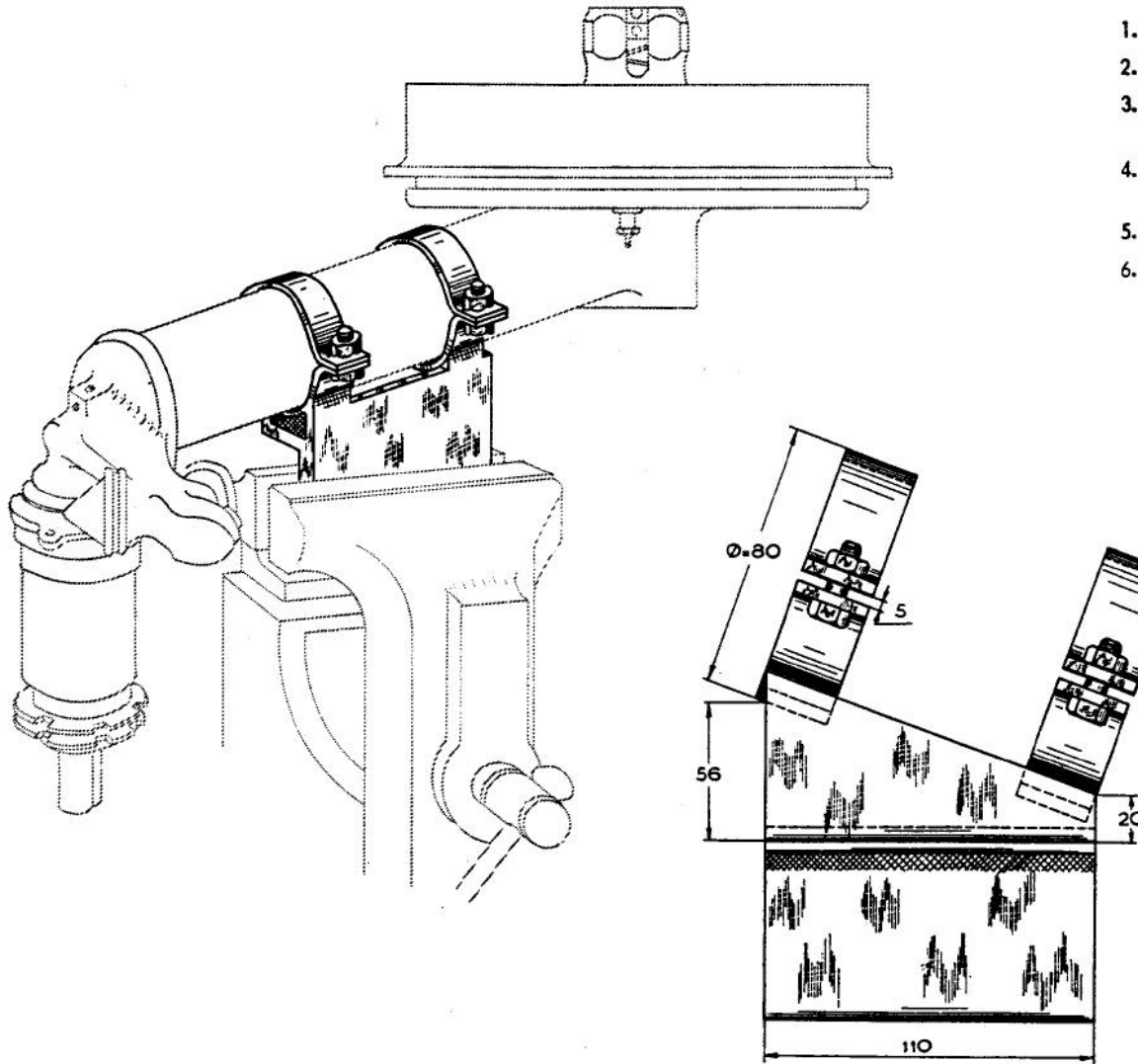
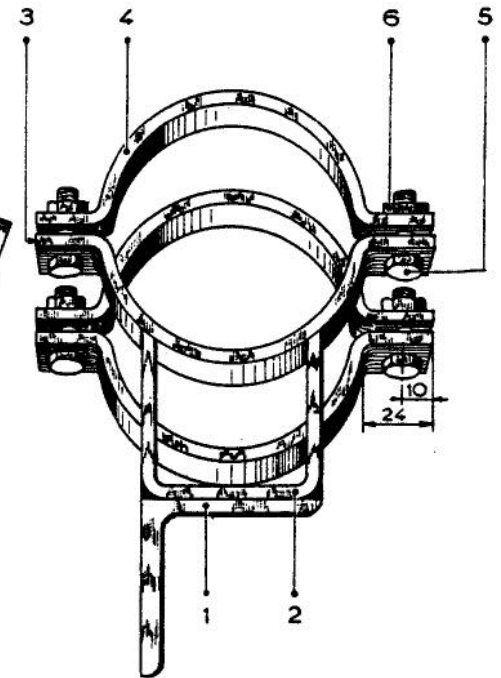

Fig. 2 - BRACKET MR-3053-90

not sold

1. 1 angle iron 60 x 60 x 6, 110 mm long
2. 1 sheet steel 4 mm thick developed length 170 mm
3. 2 split collars 4 mm thick, 25 mm wide, developed length 180 mm
4. 2 split collars 4 mm thick, 25 mm wide, developed length 180 mm
5. 4 bolts, hex. 10 mm x 1.5 x 30 mm long
6. 4 nuts, hex. 10 mm x 1.5





## EXTRACTION OF THE HUB - BRAKE DRUM

EXTRACTOR  
sold under No.2018-T

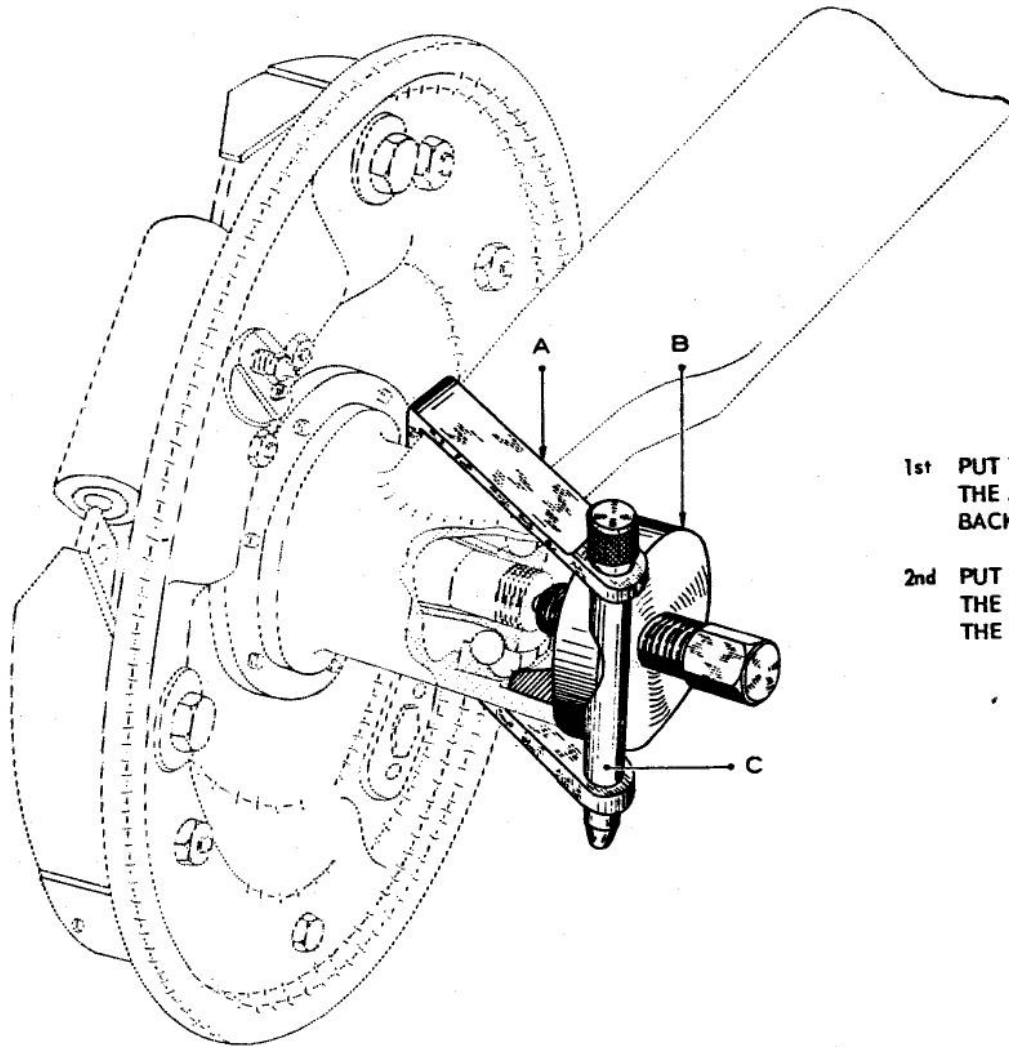

- 1st PUT THE YOKE A BETWEEN THE ARM AND THE BRAKE BACKPLATE.
- 2nd PUT THE EXTRACTOR B ON THE HUB LOCKING IT TO THE YOKE BY THE PIN C.

## EXTRACTING THE HUB BEARINGS

EXTRACTOR

sold under No.2019-T

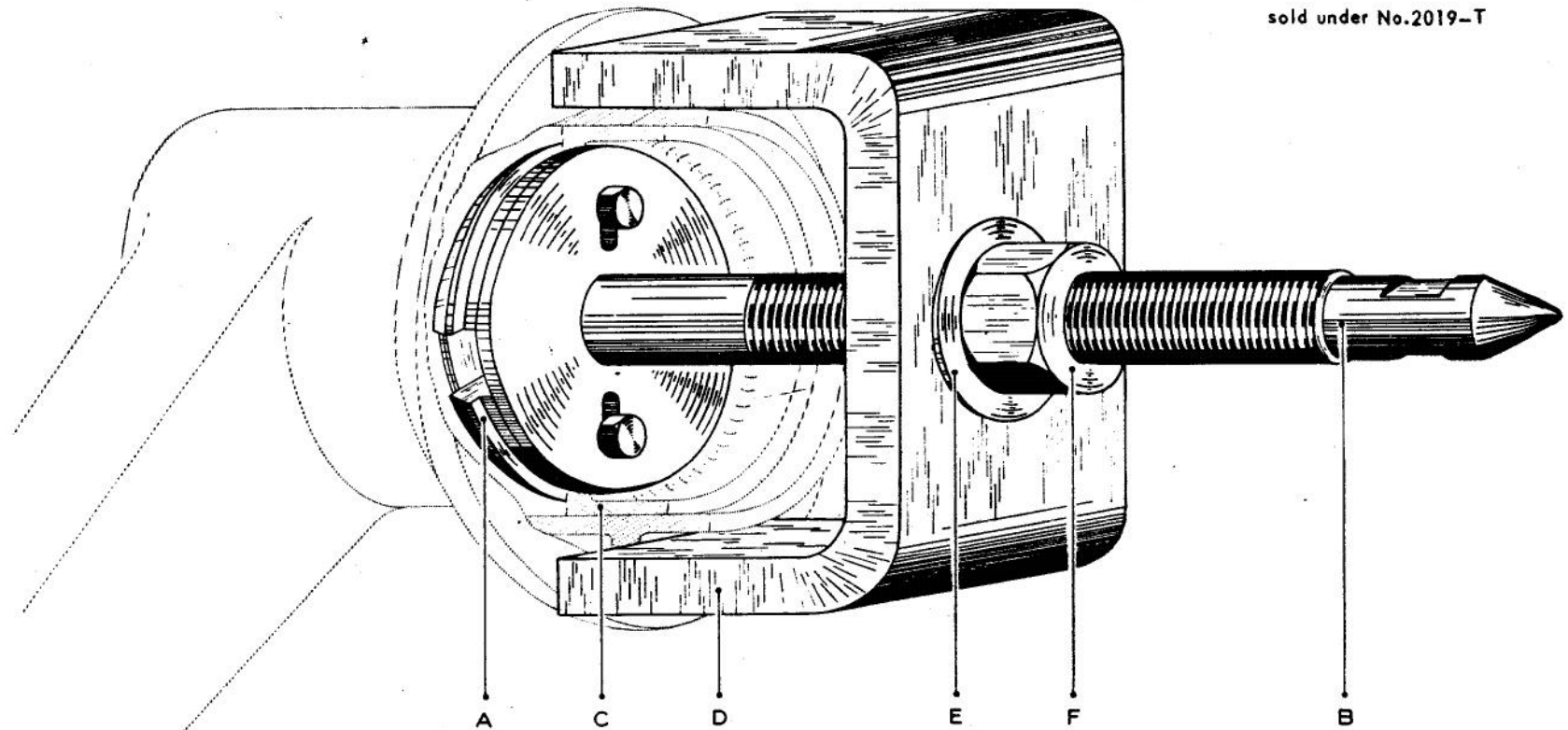

1. PLACE THE SPLIT RING A, WITHOUT THE SPINDLE B, BEHIND THE RING C
2. PUT THE SPINDLE B IN THE SPLIT RING A SO AS TO SPREAD AND LOCATE THEM
3. FIT THE U PIECE D, THE WASHER E, SCREW UP THE NUT F

NOTE: THE SPINDLE IS FITTED FROM THE INSIDE OF THE HUB

# ADJUSTMENT OF BEARING CLEARANCES

Fig 1 - CALIBRATION OF DIAL GAUGE WITH BEARING

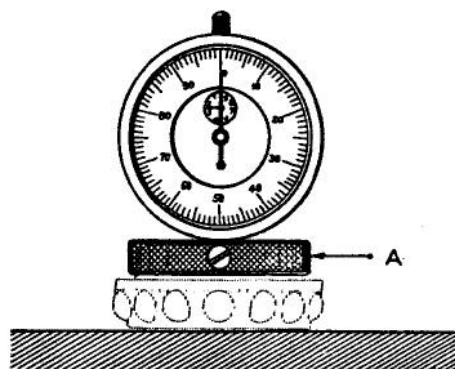

Fig 3 - FITTING THE BEARING OUTER RACES

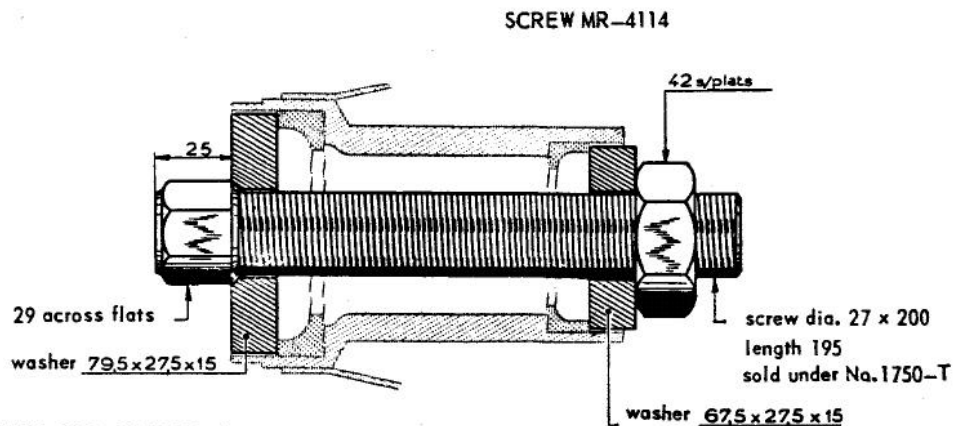
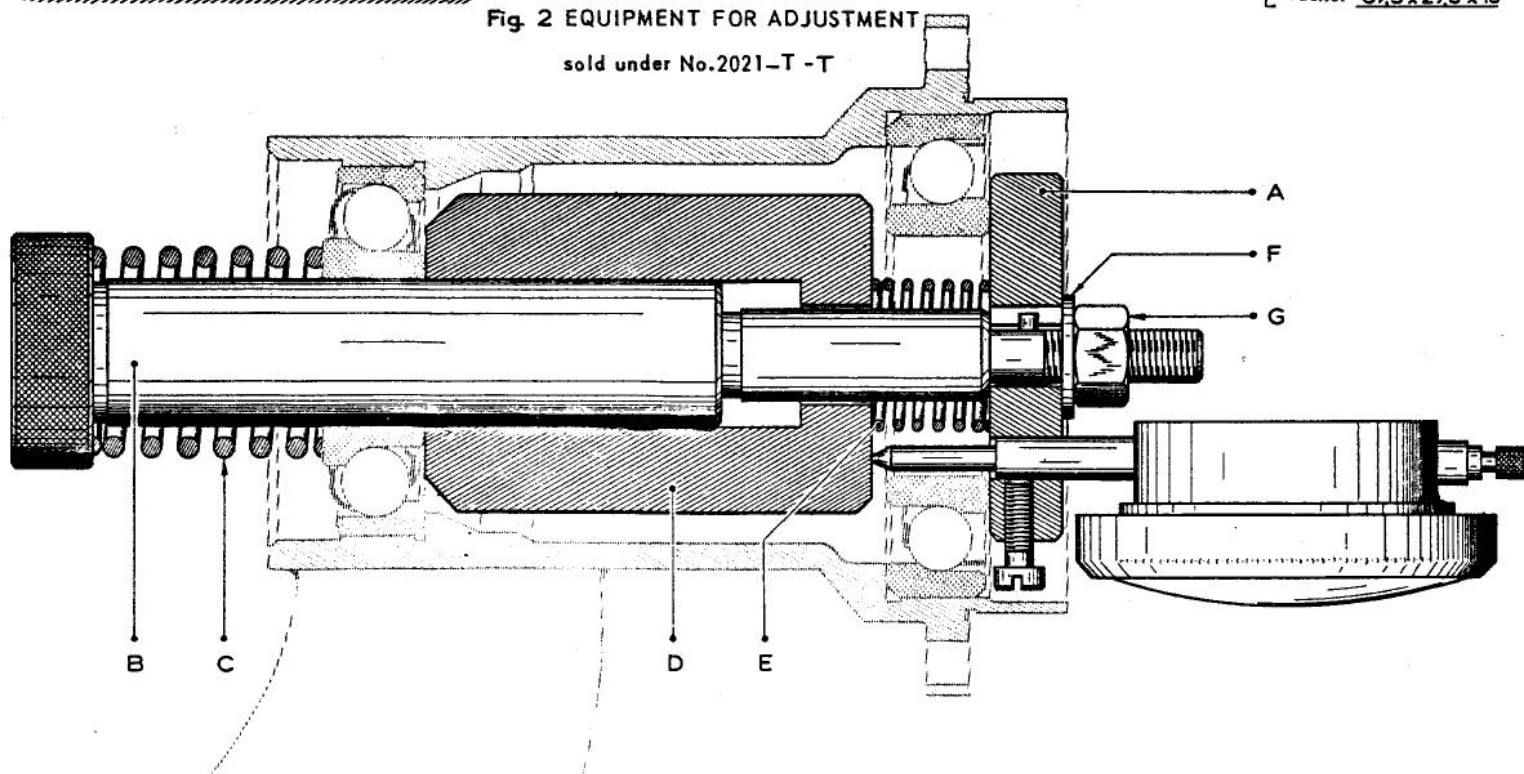
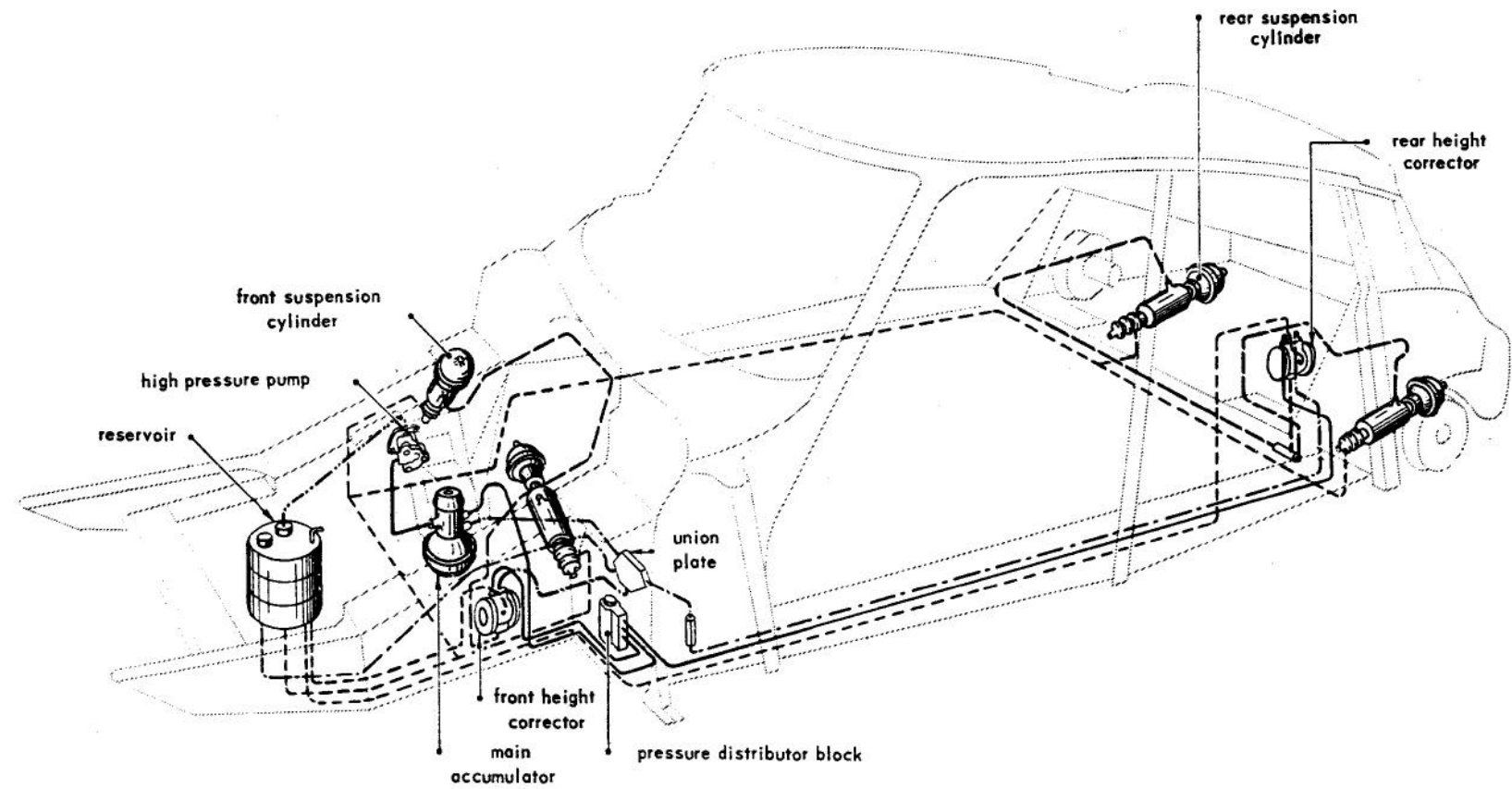

Fig 2 EQUIPMENT FOR ADJUSTMENT  
sold under No.2021-T -T



# HYDRAULIC SYSTEM



- feed
- - - two-way circulation
- high pressure
- - - exhaust return
- · - · - leakage return



# ANTI-ROLL BAR AND HEIGHT CORRECTOR CONTROL

Fig. 1

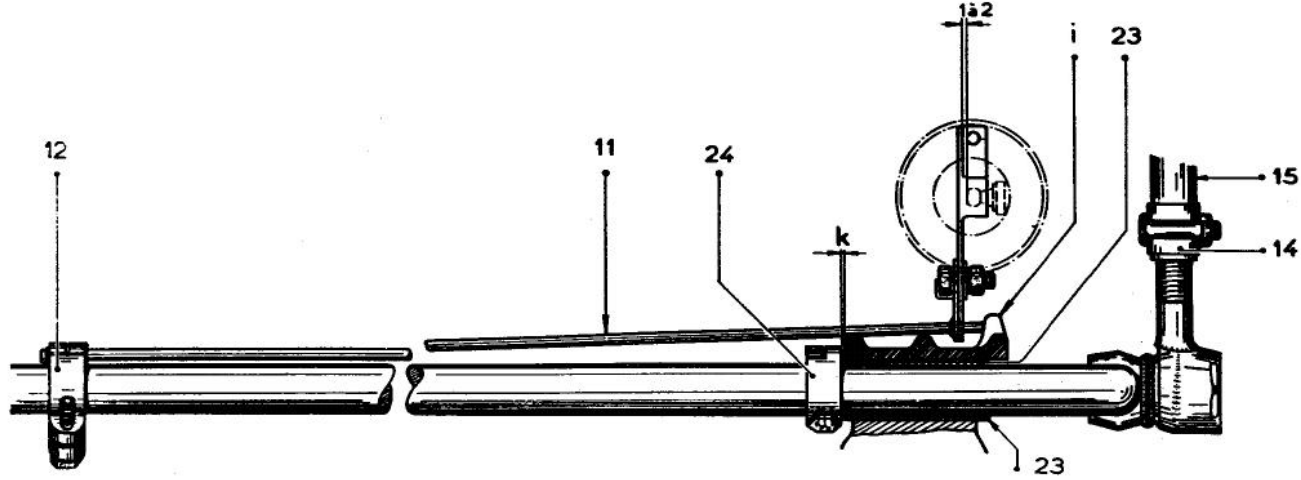

Fig. 2

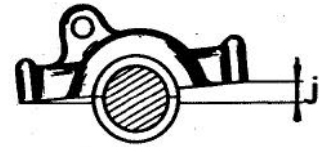

Fig. 3

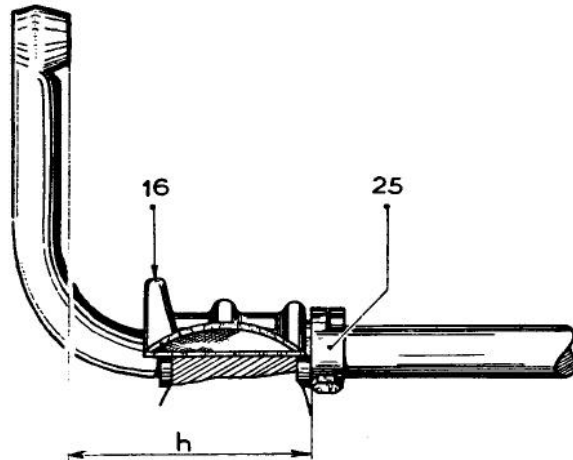

Fig. 4

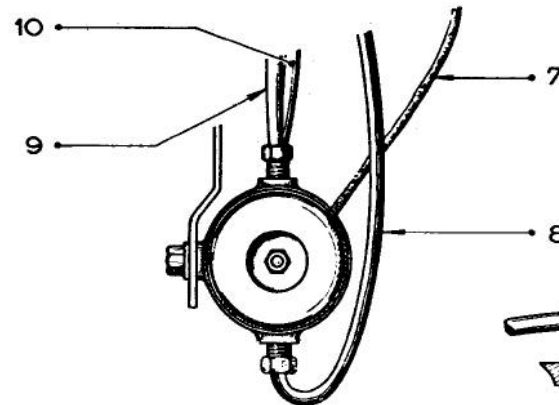
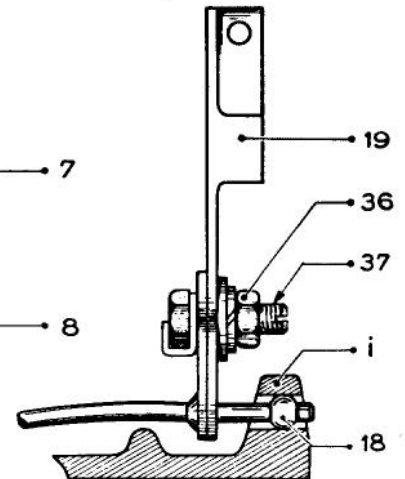
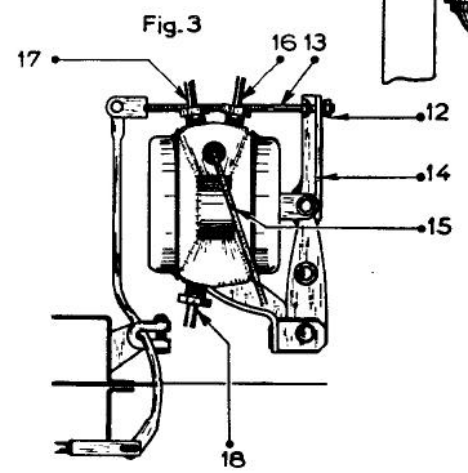
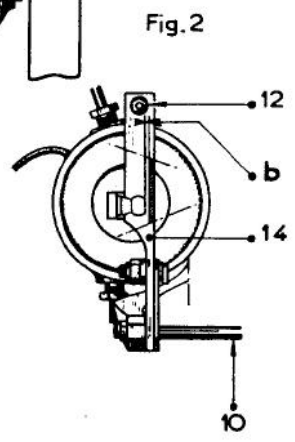
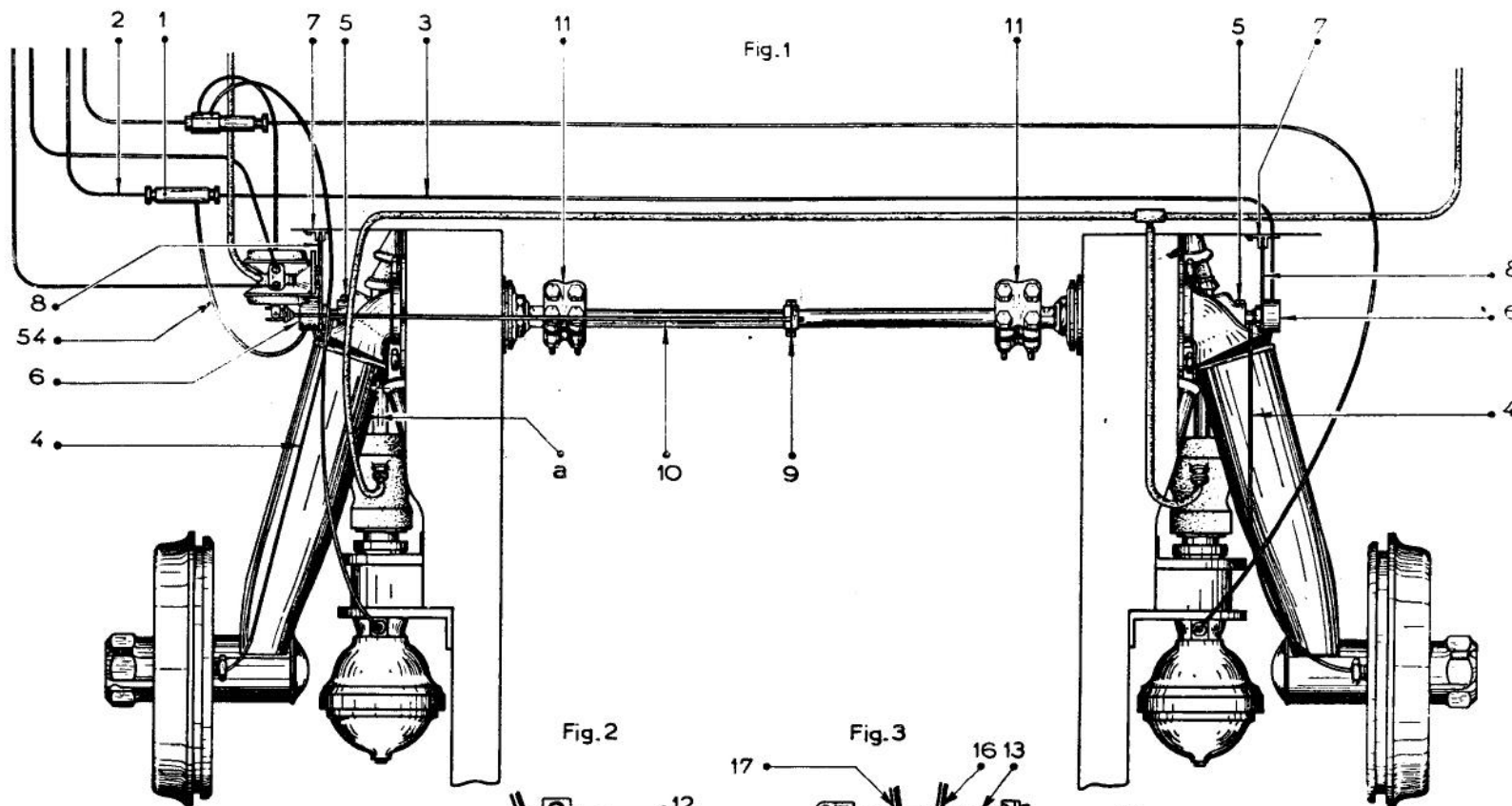

Fig. 5



REAR AXLE ASSEMBLY



REAR SUSPENSION CYLINDER

Fig. 2

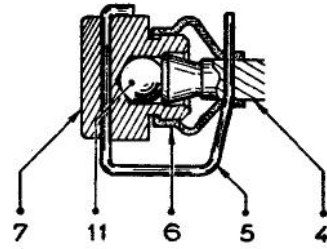

Fig. 3

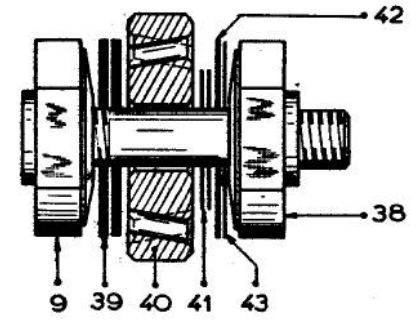
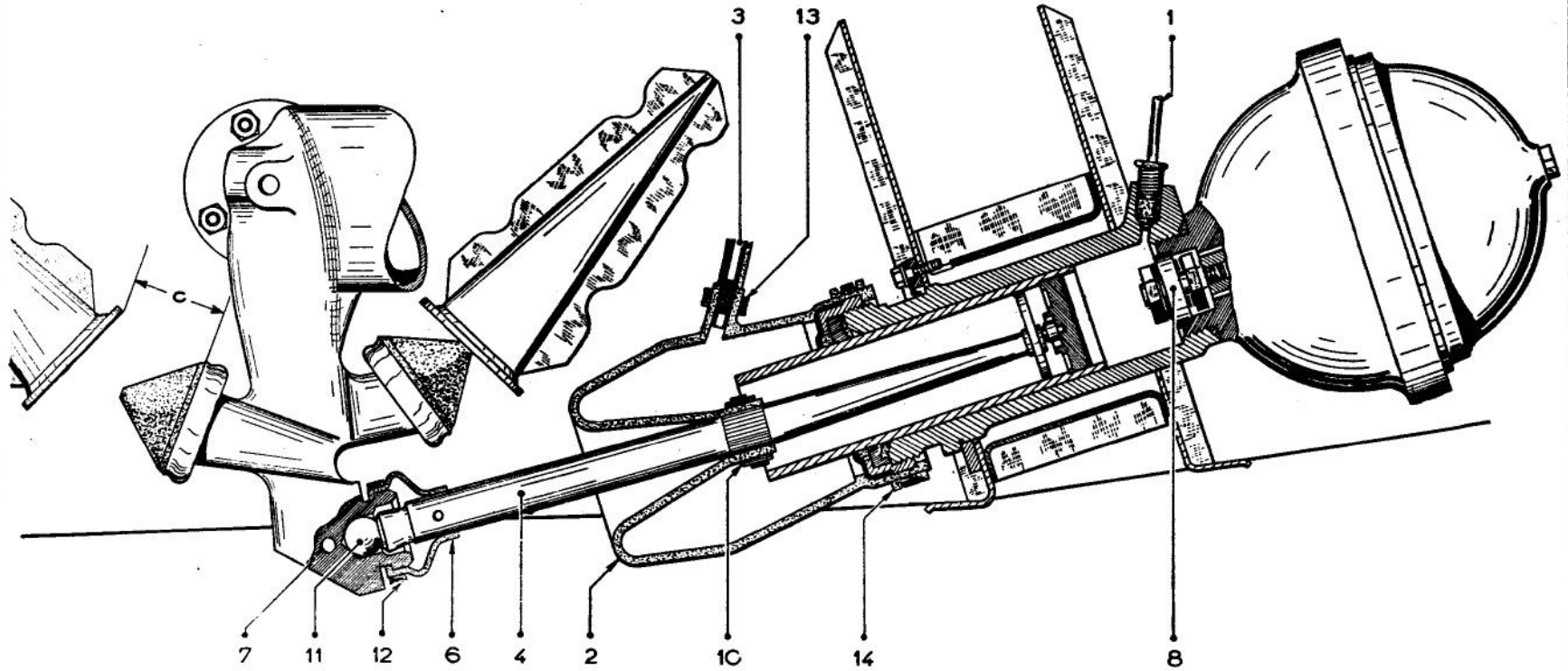

Fig. 1





MANUAL HEIGHT CONTROL GEAR

Fig. 1

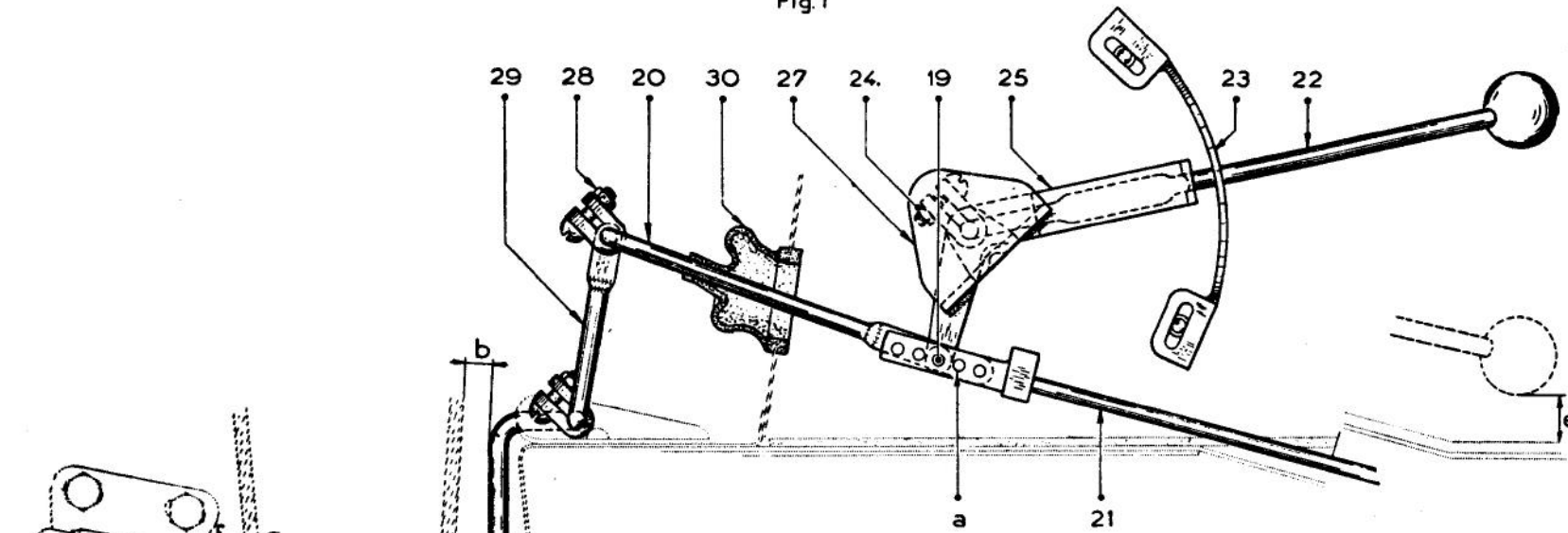
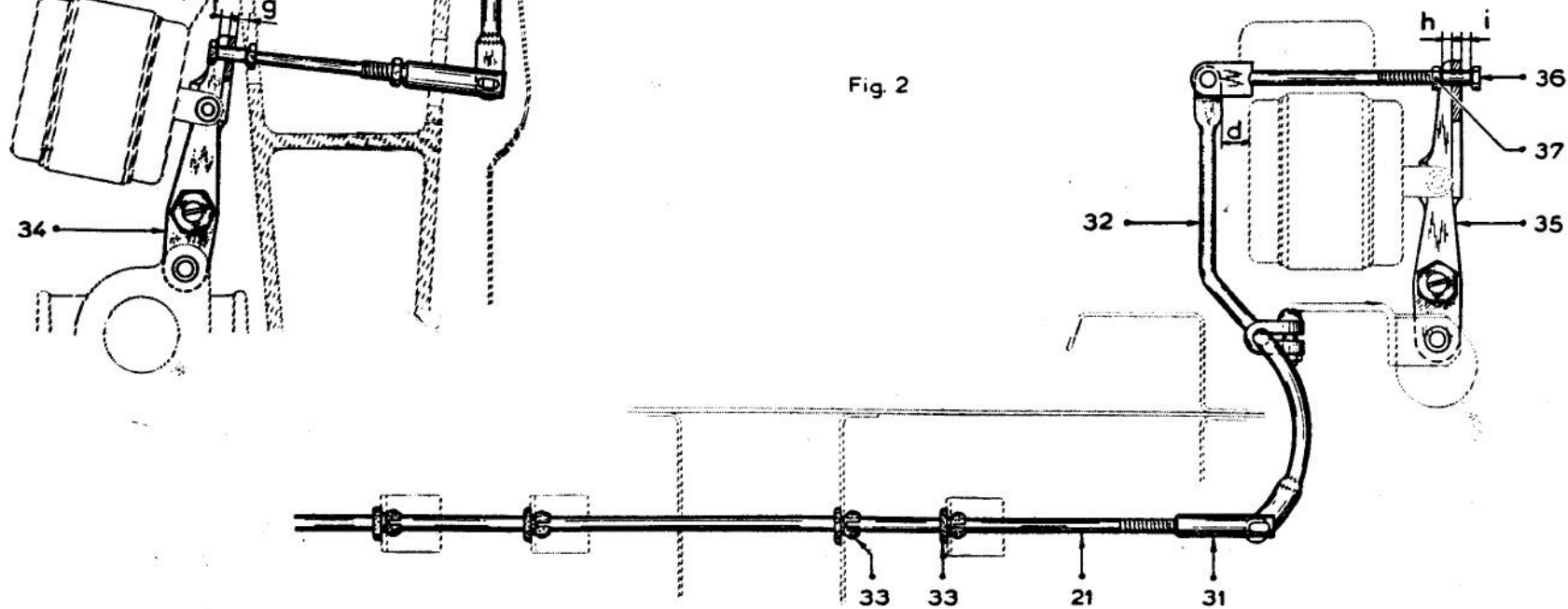

Fig. 2



# HIGH PRESSURE PUMP

Fig. 1

Fig. 2

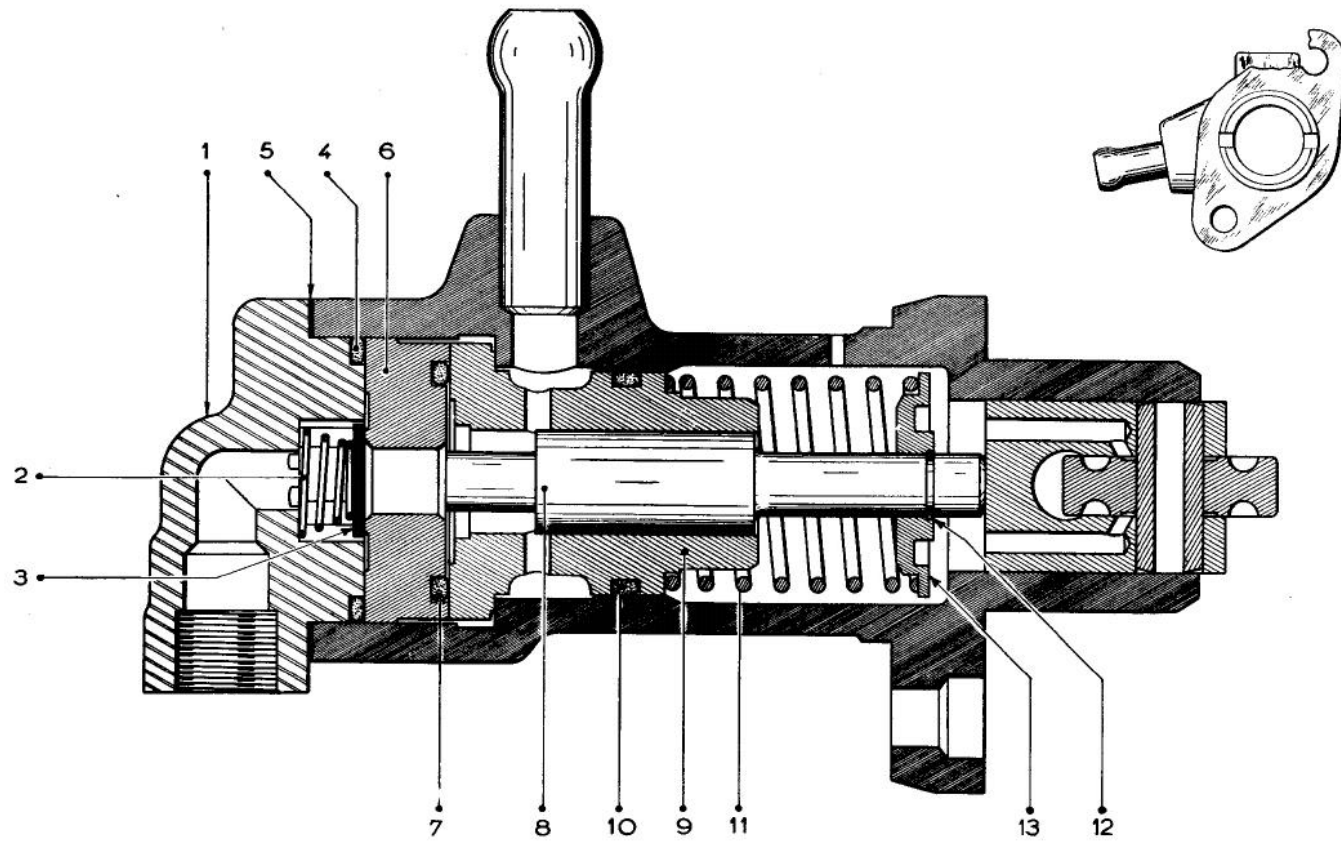

HIGH PRESSURE PUMP

Fig. 1

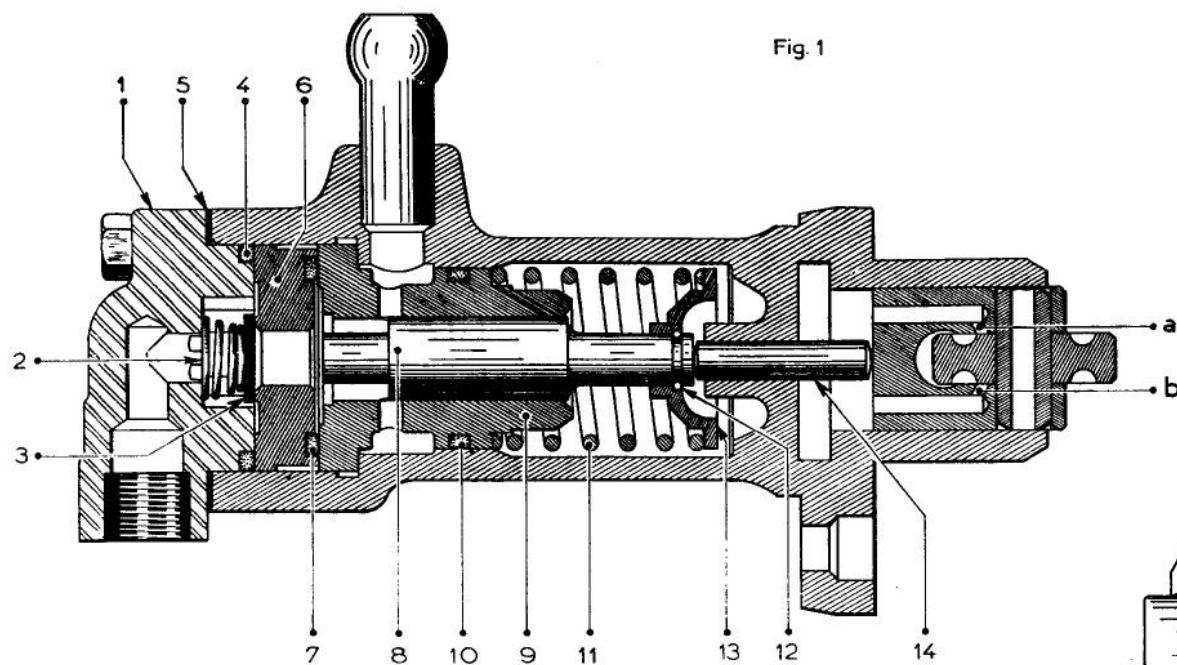

Fig. 2

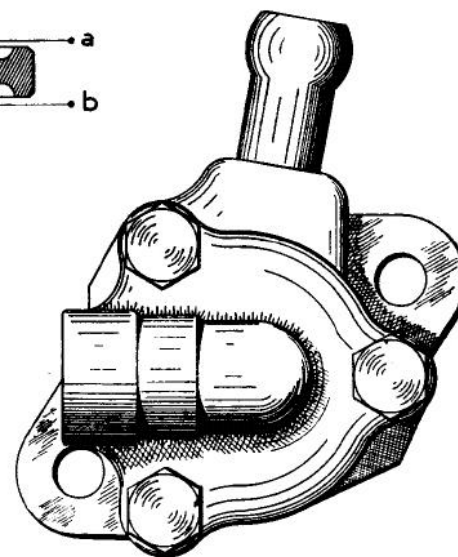
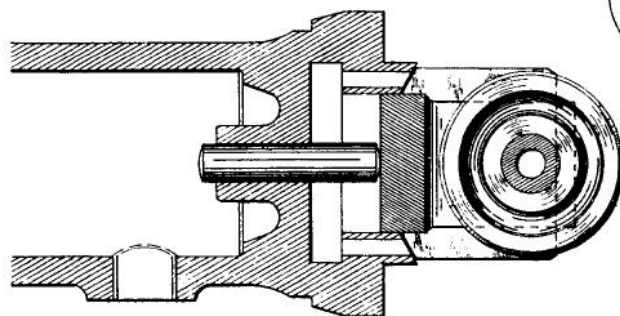
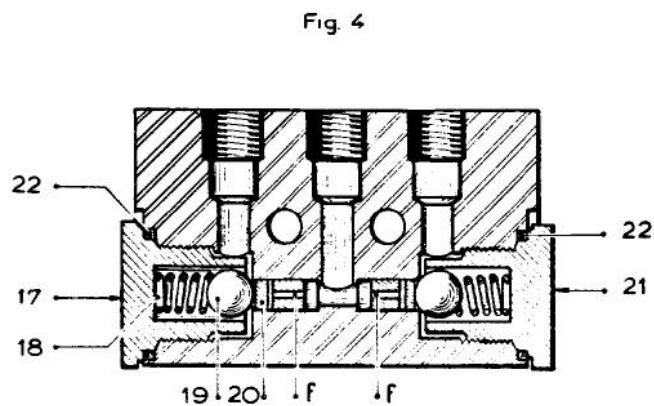
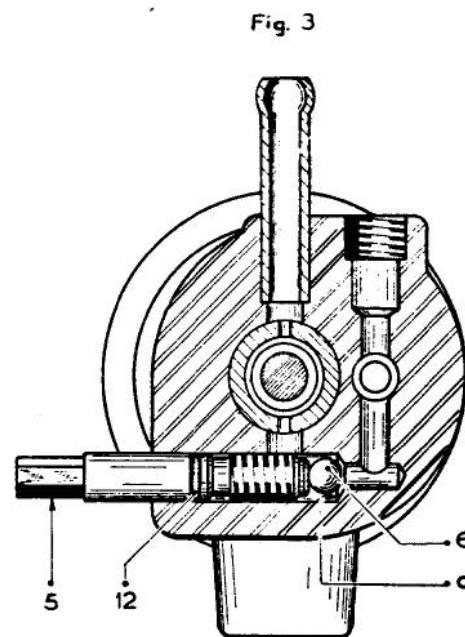
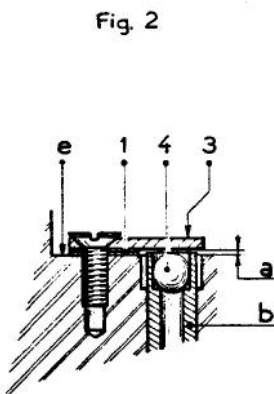
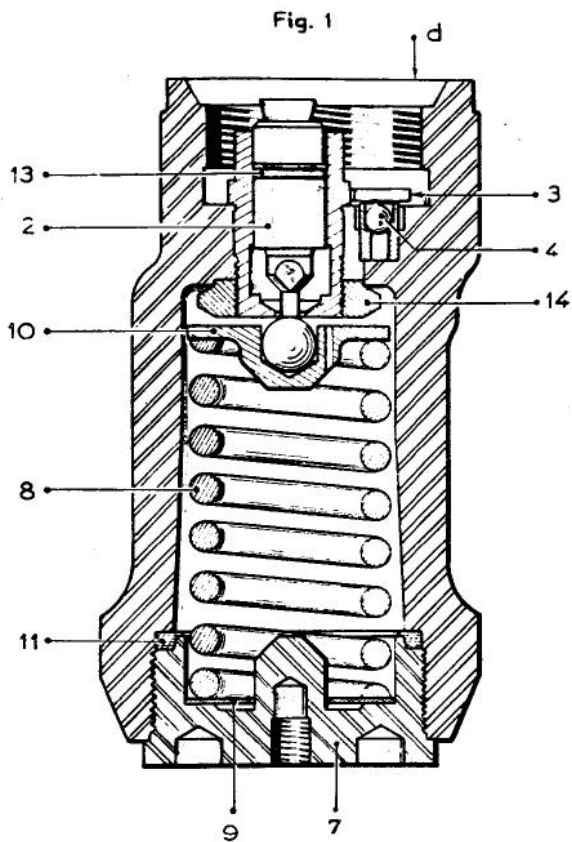

Fig. 3



PRESSURE CONTROL VALVE AND PRESSURE DISTRIBUTION BLOCK



# HEIGHT CORRECTOR - SUSPENSION CYLINDER

Fig 1

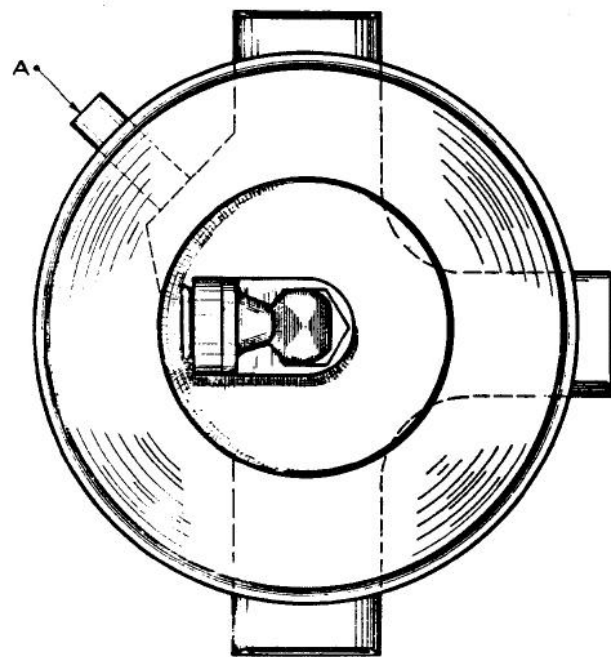

Fig 2

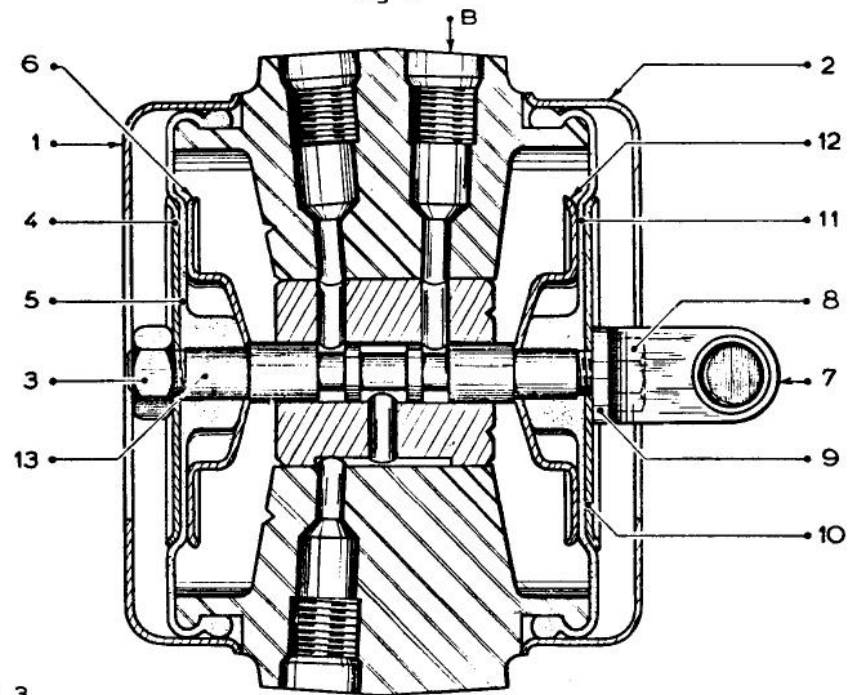
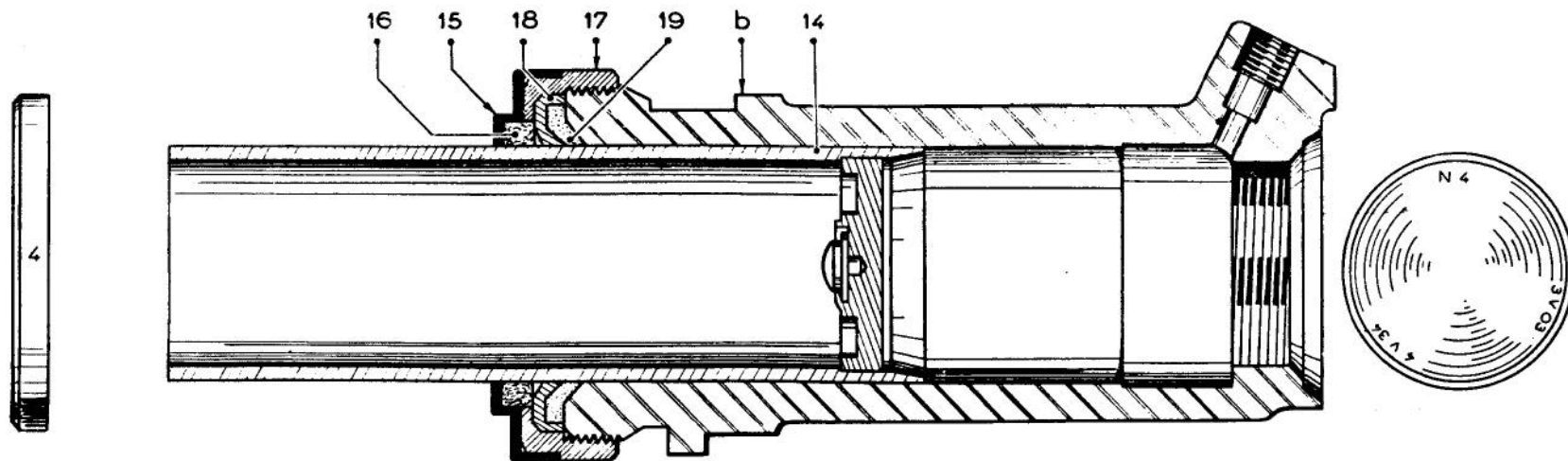

Fig 3



VARIOUS TOOLS

Fig 1 - STRAP WRENCH

sold under No.2223-T

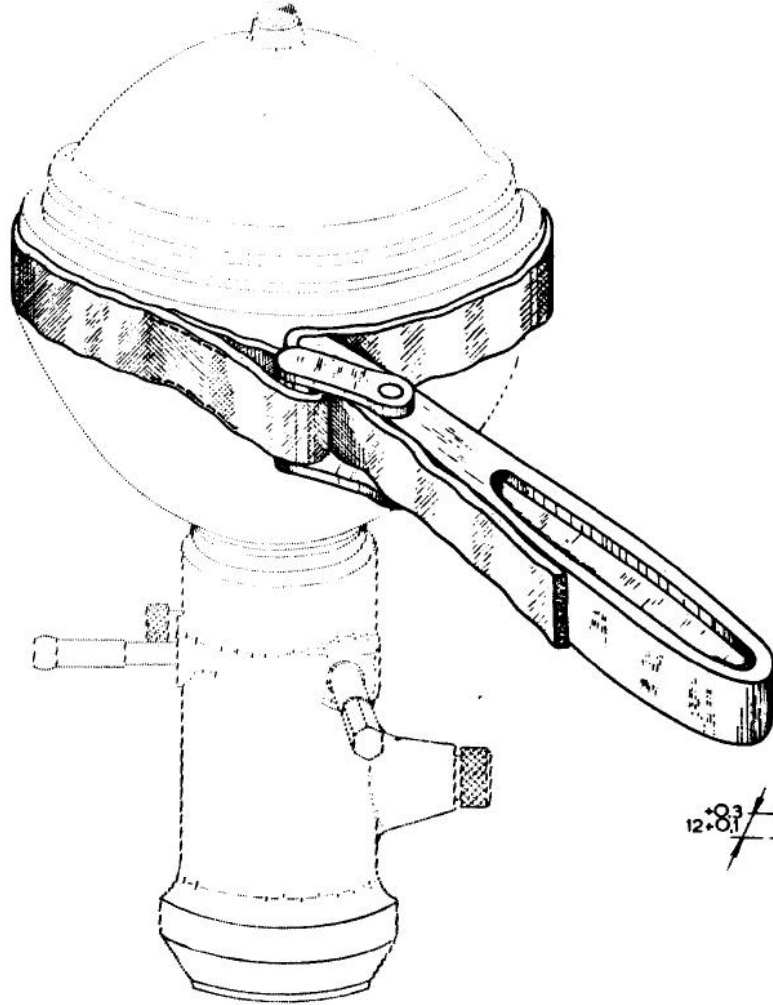

Fig 2 - ASSEMBLY

sold under No.2224-T

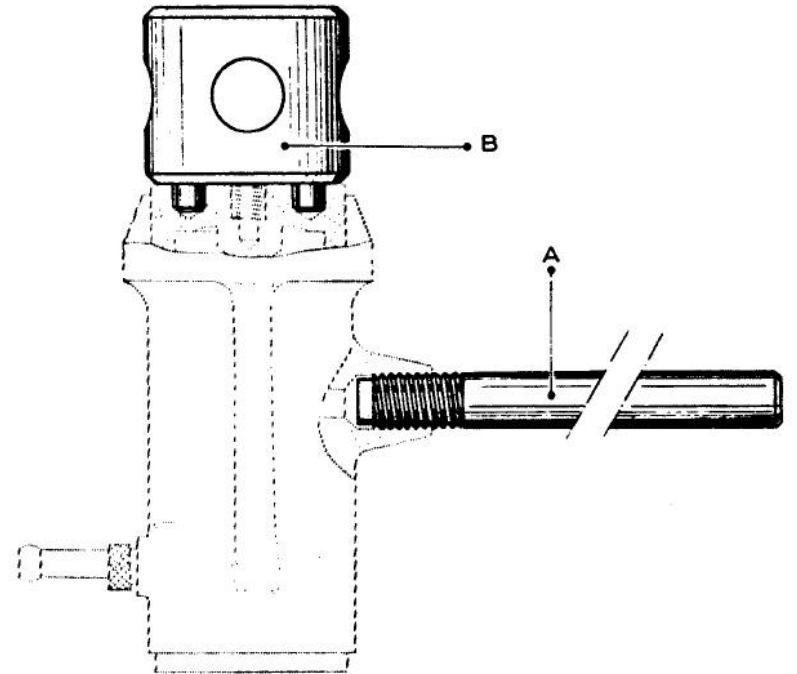
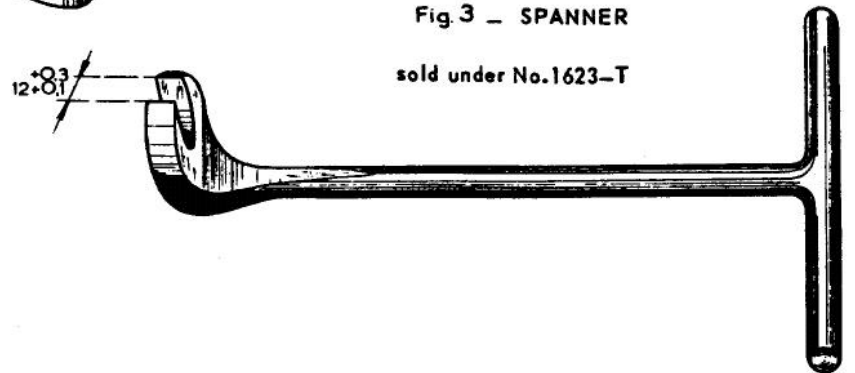

Fig 3 - SPANNER

sold under No.1623-T



VARIOUS TOOLS

Fig. 1 — FITTING THE METAL CUPS

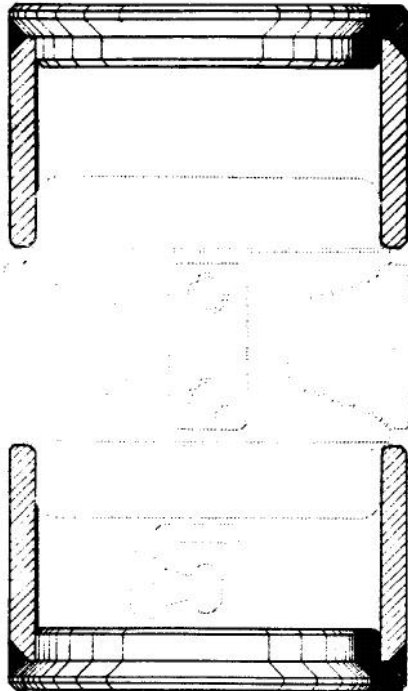

Fig 2 — PRESS TOOL MR-3045-80

not sold

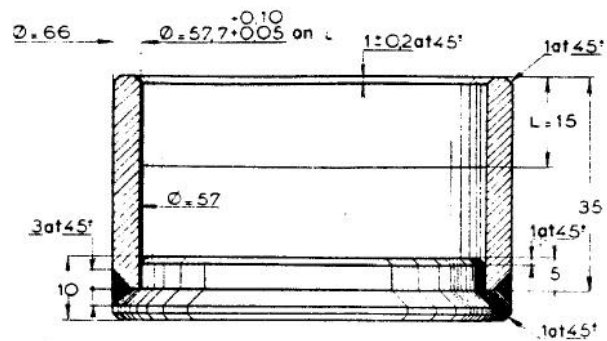

Fig. 3 — HOLDING THE CYLINDER IN A VICE

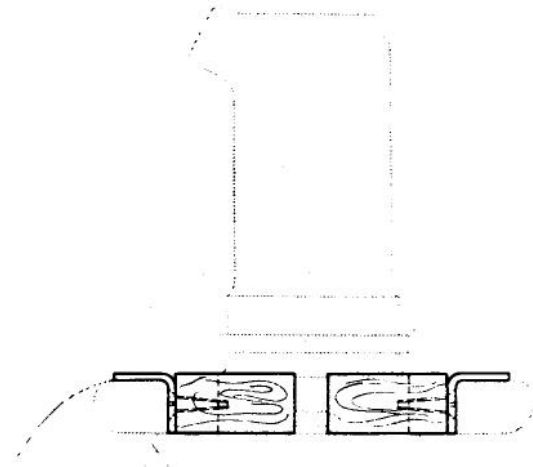
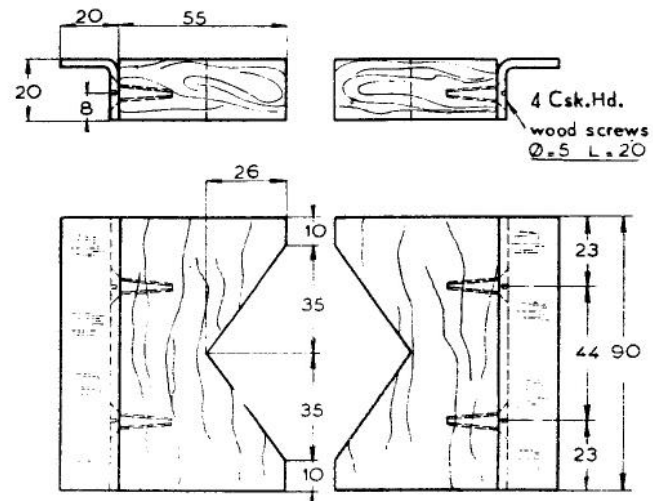
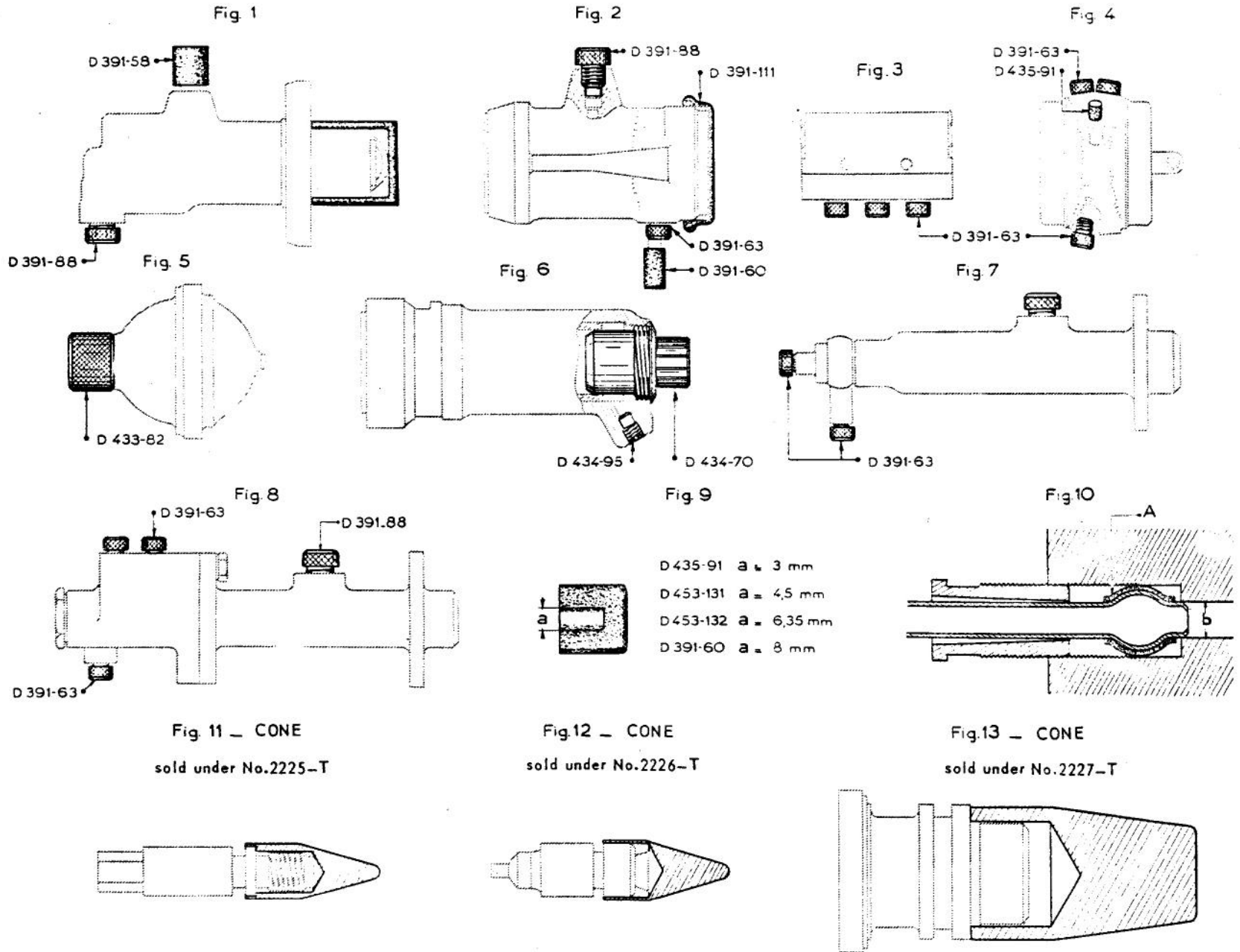

Fig 4 — WOOD JAWS MR-3407-30

not sold



SEALING PLUGS - TAPERED SLEEVES





ASSEMBLY

Fig 1

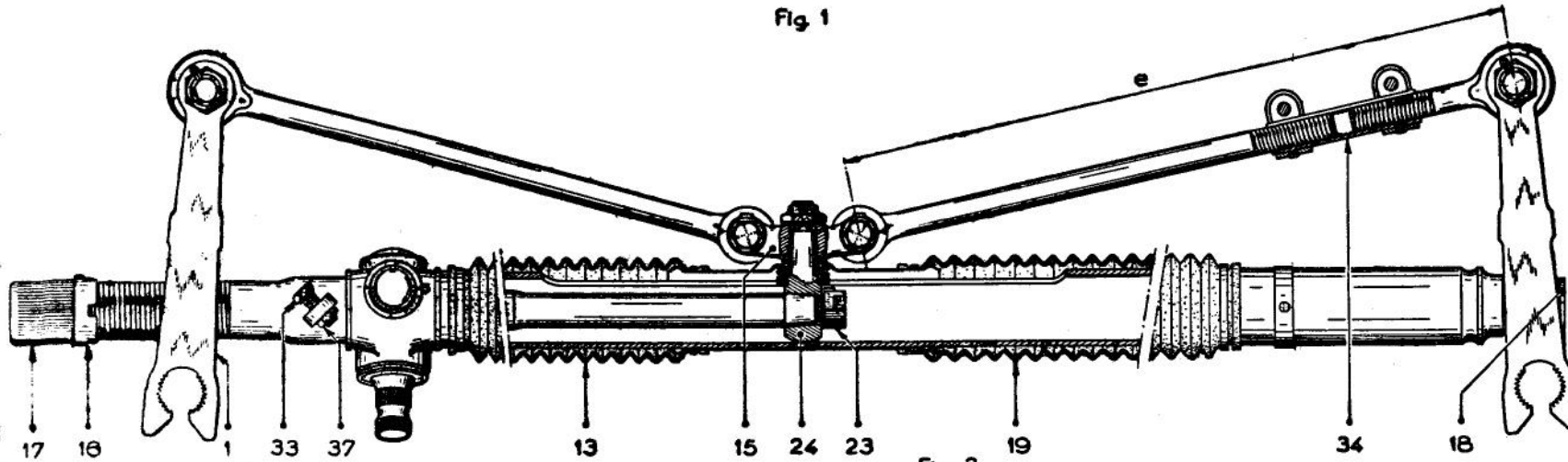

Fig 2

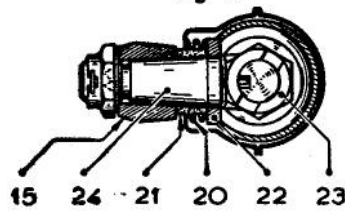

Fig 3

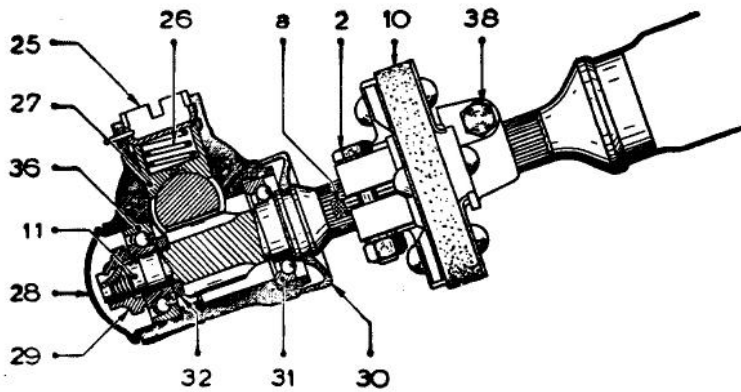
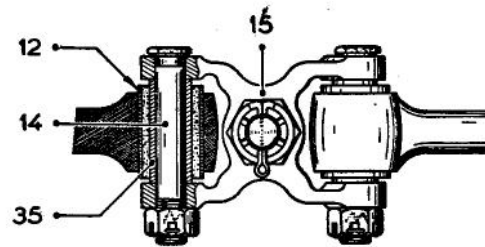

Fig 4



OPERATIONS

- ID 100-1
- ID 330-1
- ID 334-1
- ID 440-0
- ID 441-1
- ID 442-1
- ID 443-1

STEERING

FITTING THE STEERING WHEEL

Fig. 1 - COMPRESSING TOOL

sold under No.1991-T

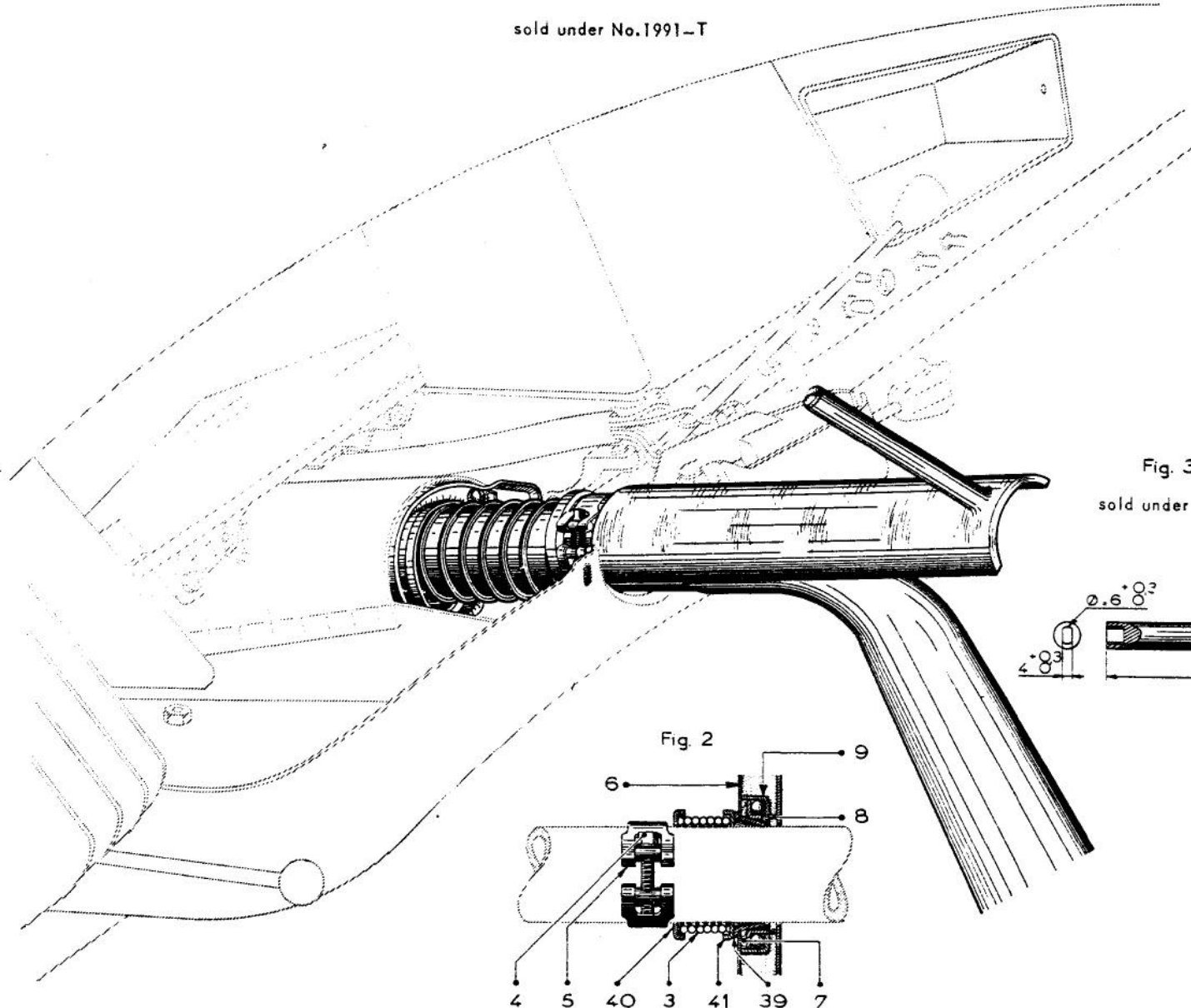

Fig. 3 - SPANNER

sold under the No.1994-T

VARIOUS TOOLS

Fig 1 - EXTRACTOR

sold under No.1966-T

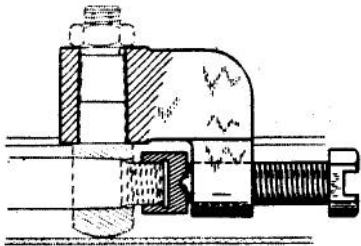

Fig 2 - EXTRACTOR

sold under No.1967-T

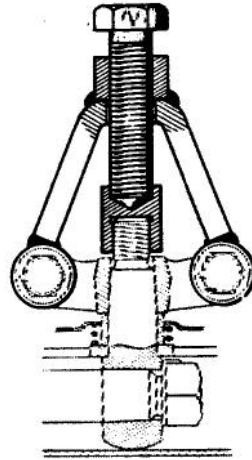

Fig 3 - SPANNER

sold under No.1987-T



Fig 4 - SPANNER

sold under No.1854-T

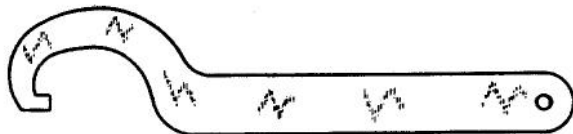
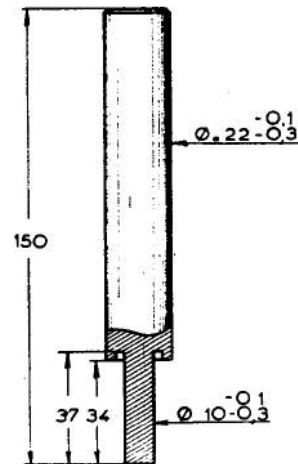

Fig 5 - MANDREL MR-3676-110

not sold



OPERATIONS  
ID 100-1  
ID 330-1  
ID 440-0  
ID 442-1

STEERING

ID 19

93

VARIOUS TOOLS

Fig 1 - SUPPORT  
sold under No.1999-T

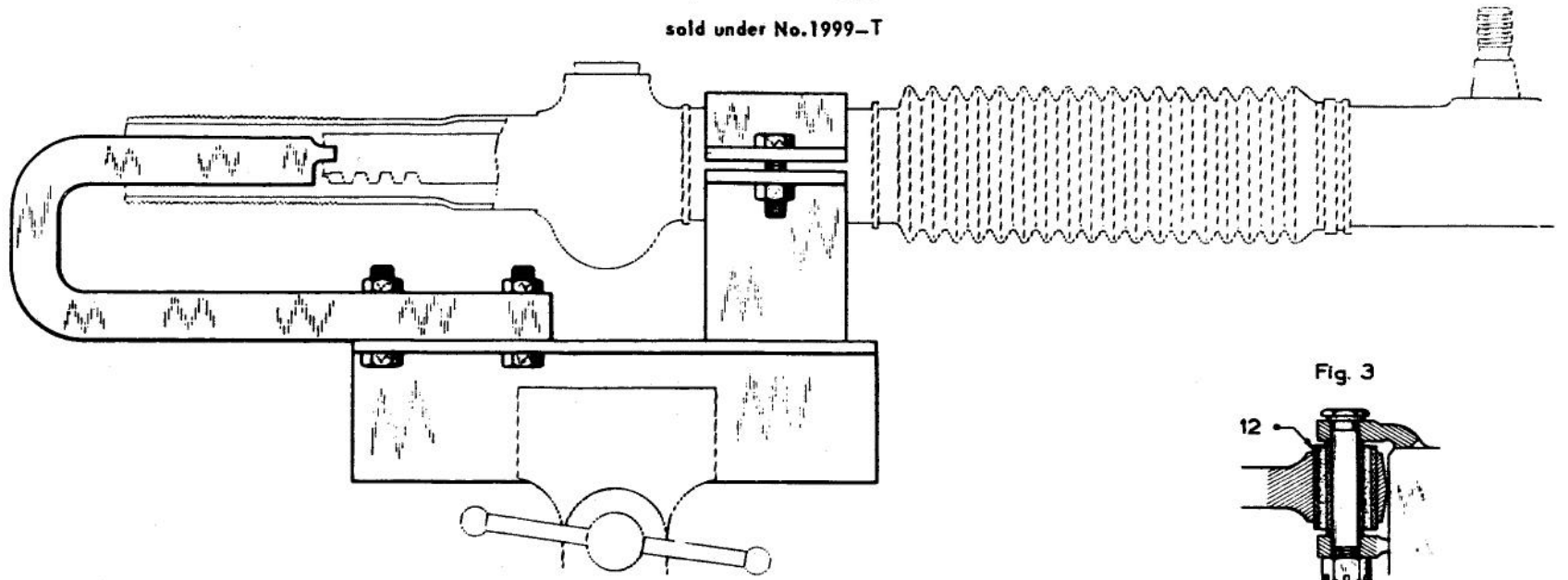
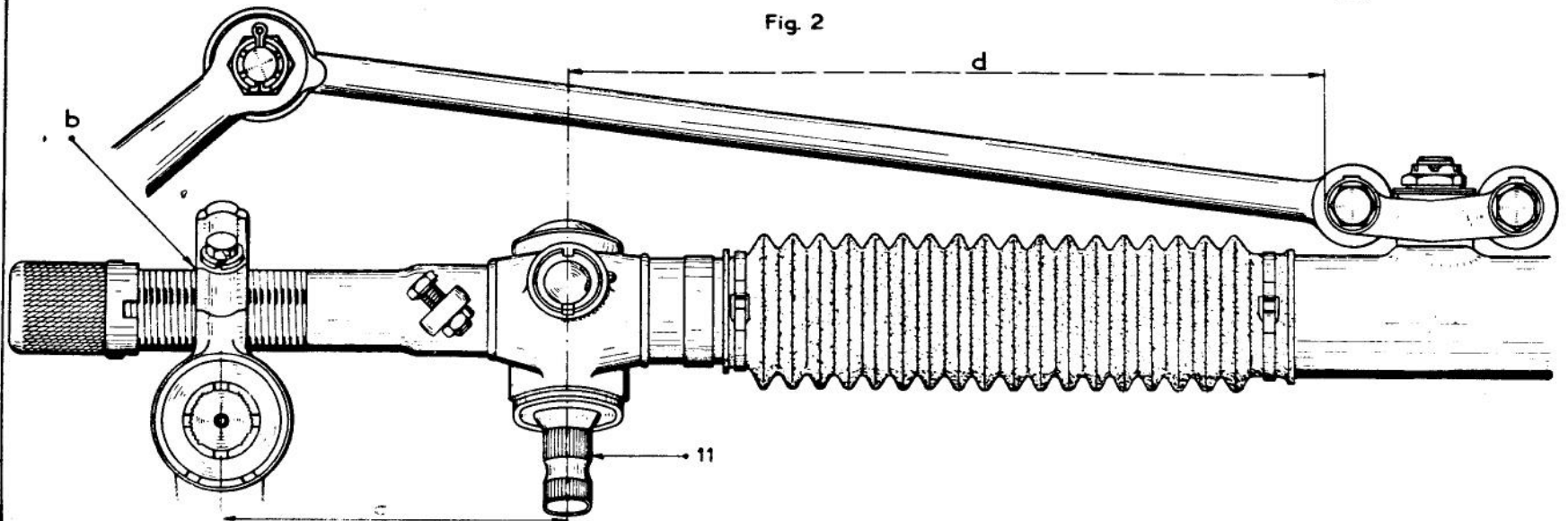
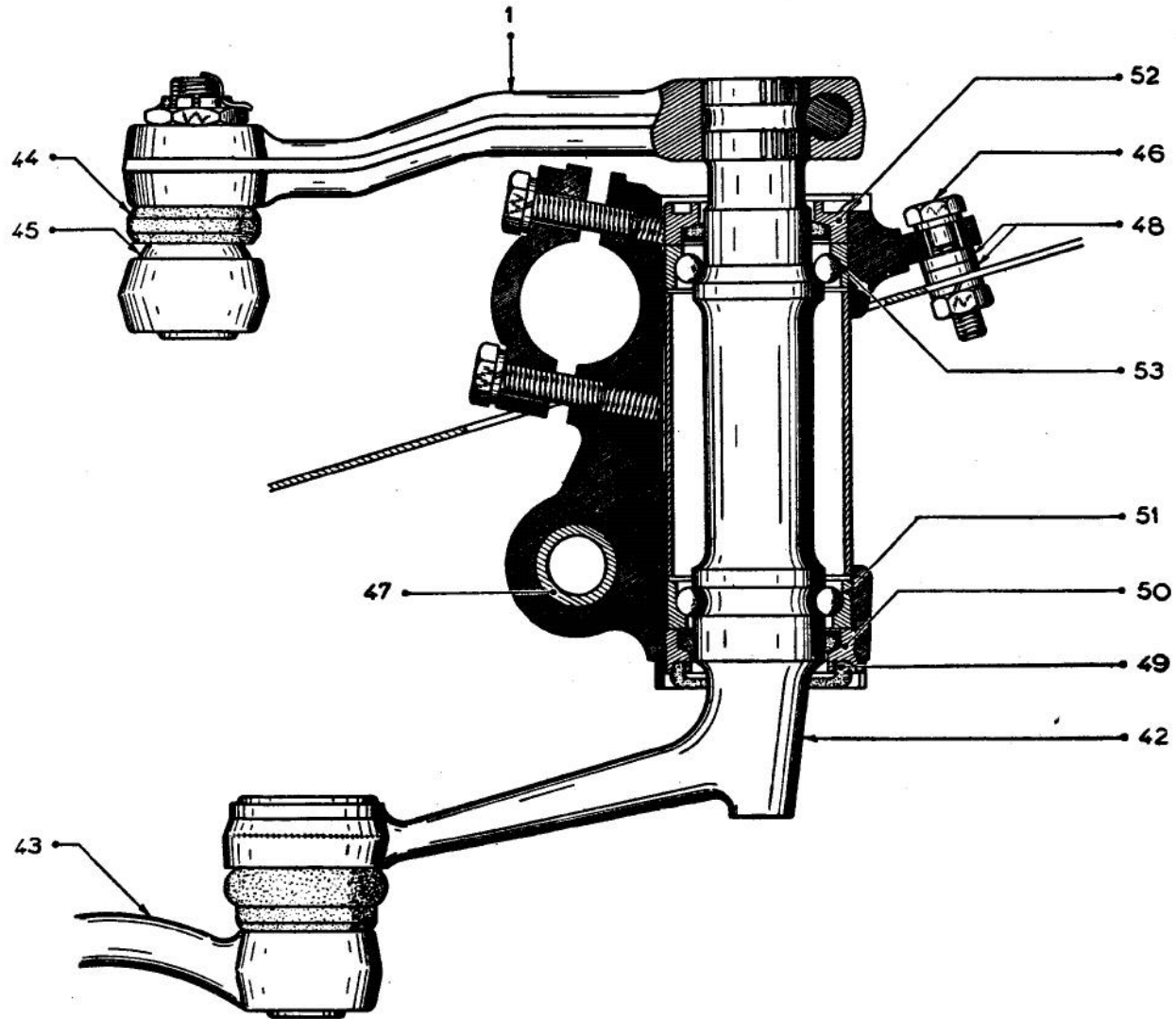

Fig. 2



SECTION OF THE RELAY



## ADJUSTING THE POSITION OF A RELAY

1. FIT THE SPINDLE A IN THE UPPER REAR HOLE OF THE CROSSMEMBER.
2. FIT THE POINT OF THE GAUGE PIN B IN THE CENTRE POINT OF THE RELAY SPINDLE.
3. DETERMINE THE THICKNESS OF THE ADJUSTING WASHER 62 TO BE FITTED AT f.
4. FIT THE WASHER 62, TIGHTEN THE SCREW C, TIGHTEN THE SPINDLE NUT 60.
5. AGAIN FIT THE FIXTURE 1995-T IN ORDER TO CHECK THE POSITION OF THE RELAY LEVERS.

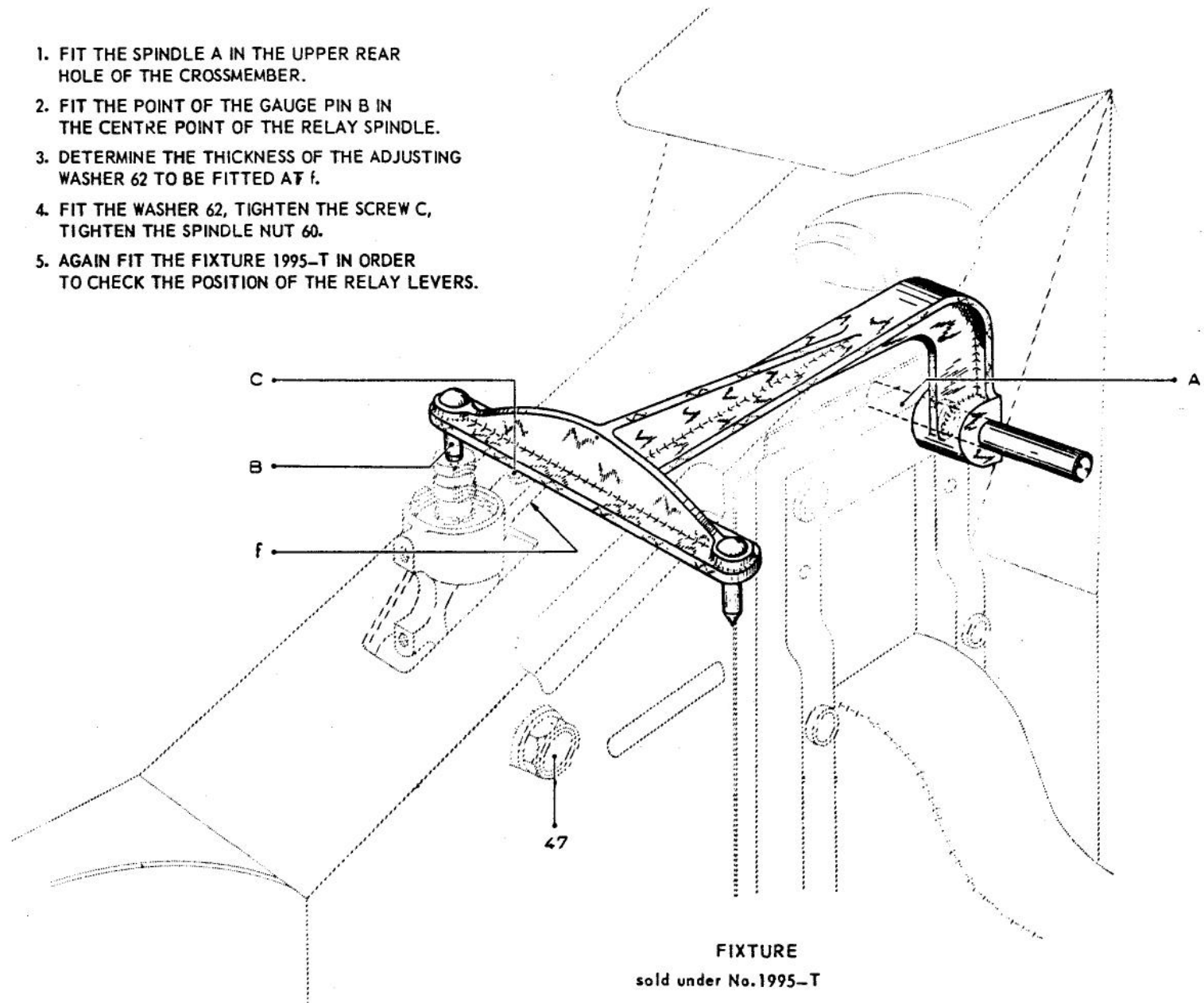

FIXTURE  
sold under No. 1995-T

VARIOUS TOOLS

Fig 1 - SPANNER  
sold under No.1989-T



Fig 2 - SPANNER MR-3691-70  
not sold

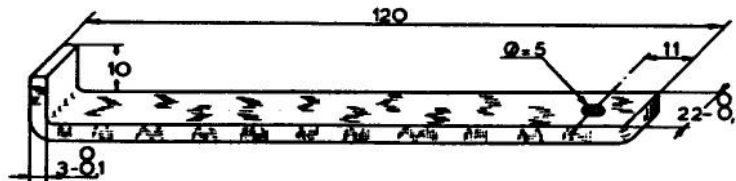

Fig 3 - BOX SPANNER  
sold under No.1988-T

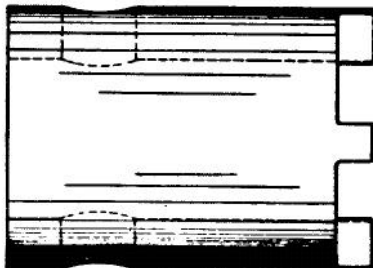
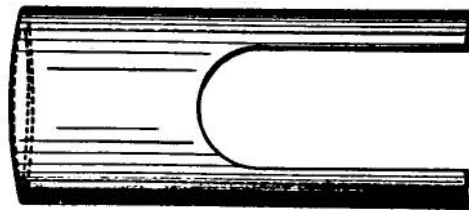

Fig 4 - TUBE  
sold under No.1990-T



# ADJUSTMENT OF THE PINION

Fig. 1. SETTING THE DIAL GAUGE

Fig. 2. MEASURING THICKNESS OF ADJUSTING WASHER

Fig. 3. FITTING THE BALL BEARINGS IN POSITION

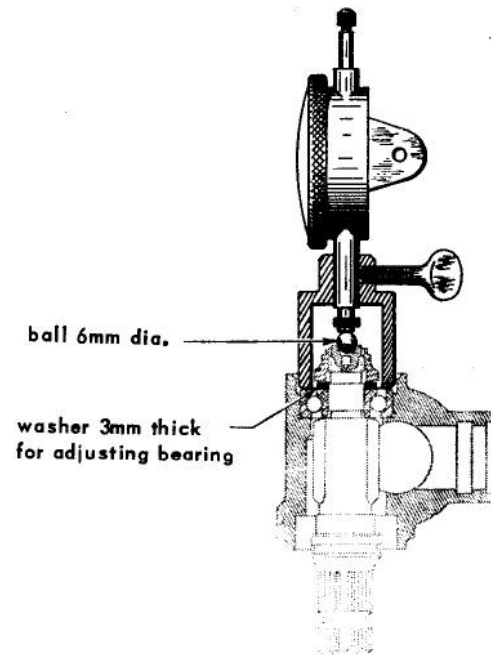

SUPPORT FOR DIAL GAUGE AND CONTACT PLUG

sold under No. 1997-T

FIGURE  
sold under No. 1996-T

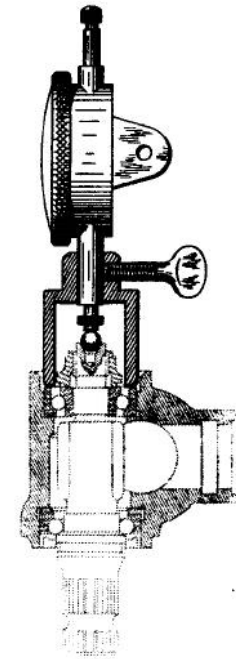
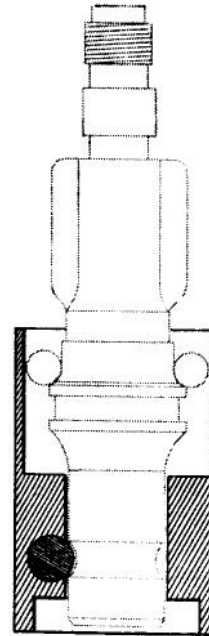

DIAL GAUGE

sold under No. 2437-T



# HYDRAULIC SYSTEM FOR BRAKES

1st ARRANGEMENT

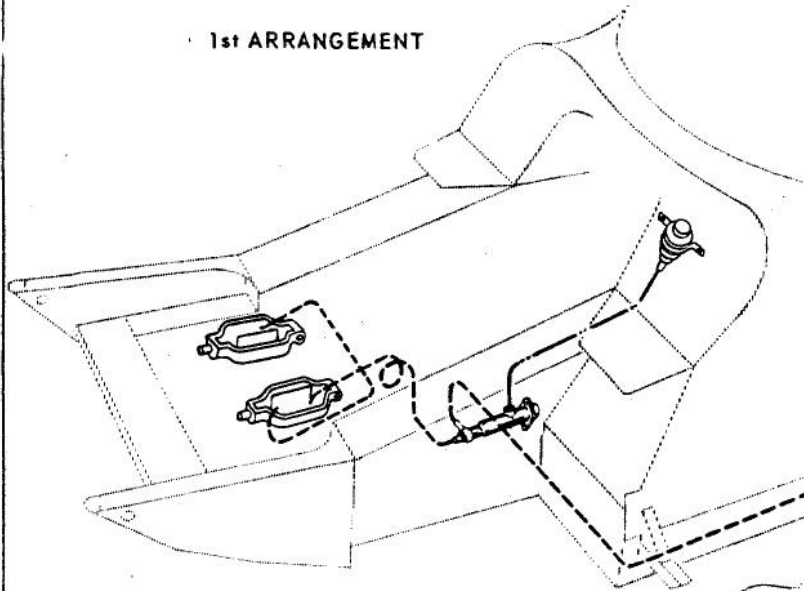

high pressure ———  
exhaust return - - - -  
two-way flow - - - -  
feed - - - -

2nd ARRANGEMENT

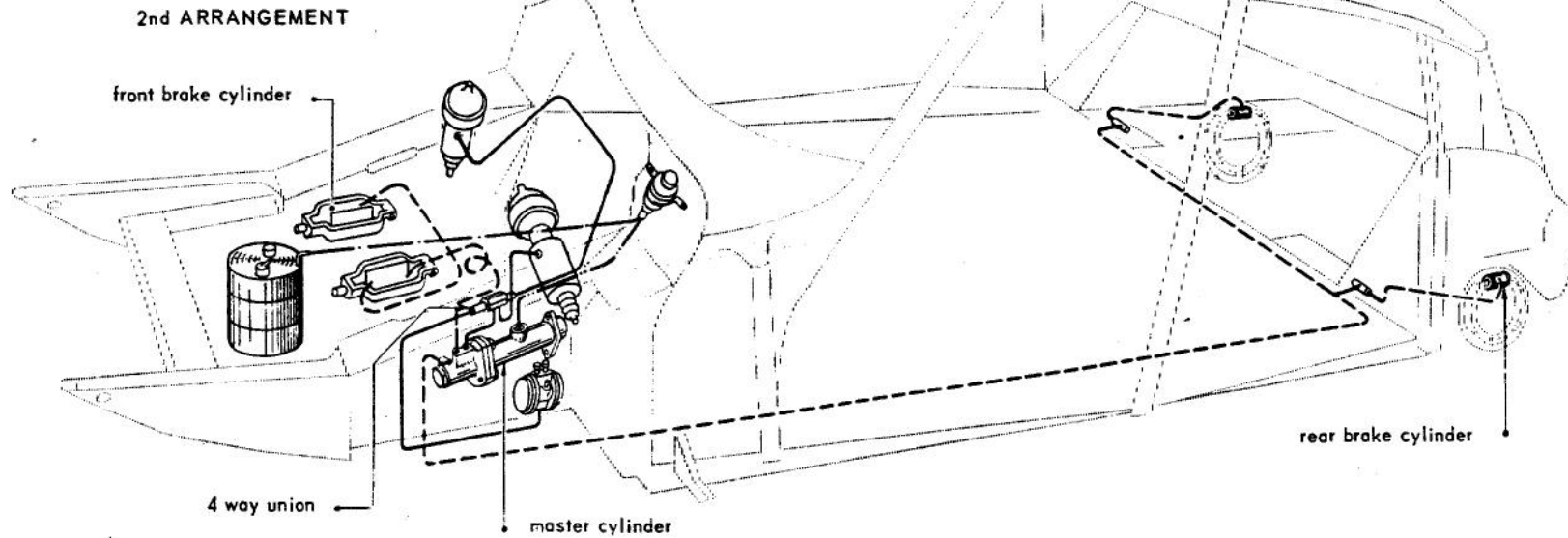

front brake cylinder

4 way union

master cylinder

rear brake cylinder

OPERATIONS

ID 330-1

ID 330-2

ID 331-1

ID 451-O

ID 451-1

ID 451-3

BRAKES

ID 19

99

FRONT BRAKE UNIT

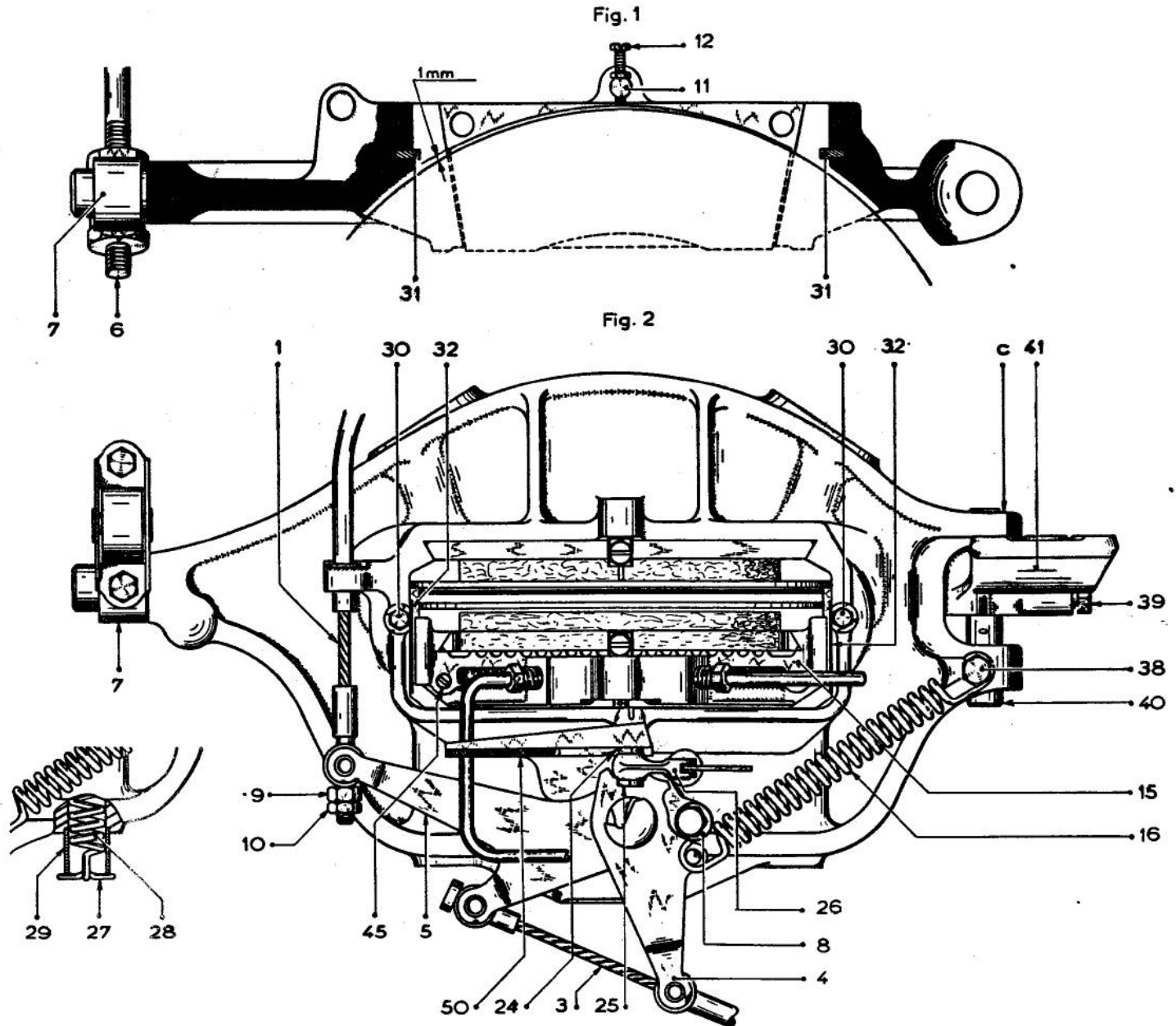

FRONT BRAKE UNIT

Fig. 1

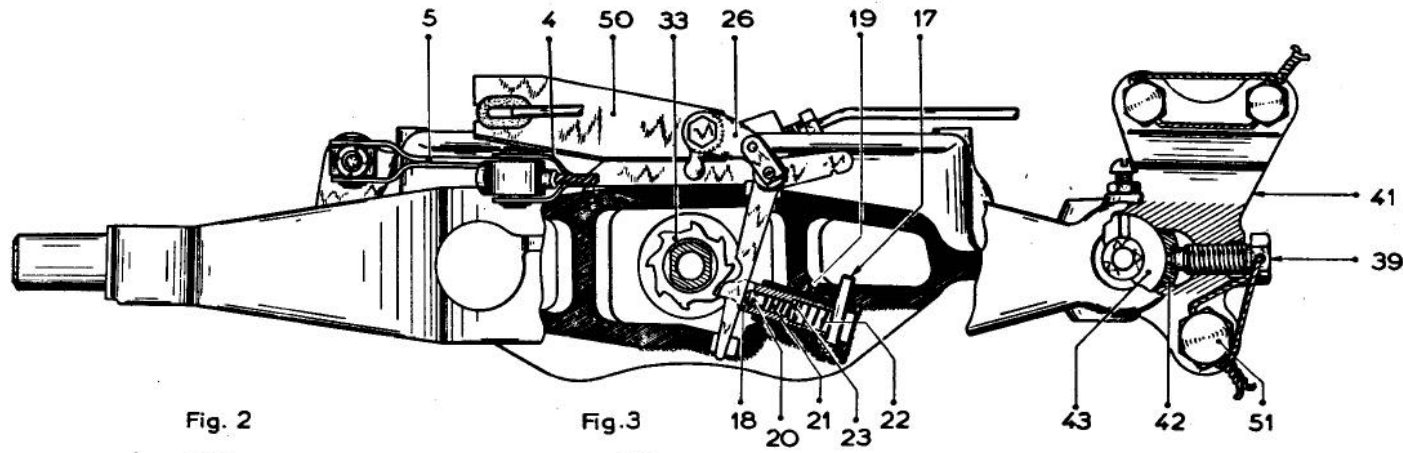

Fig. 2

Fig. 3

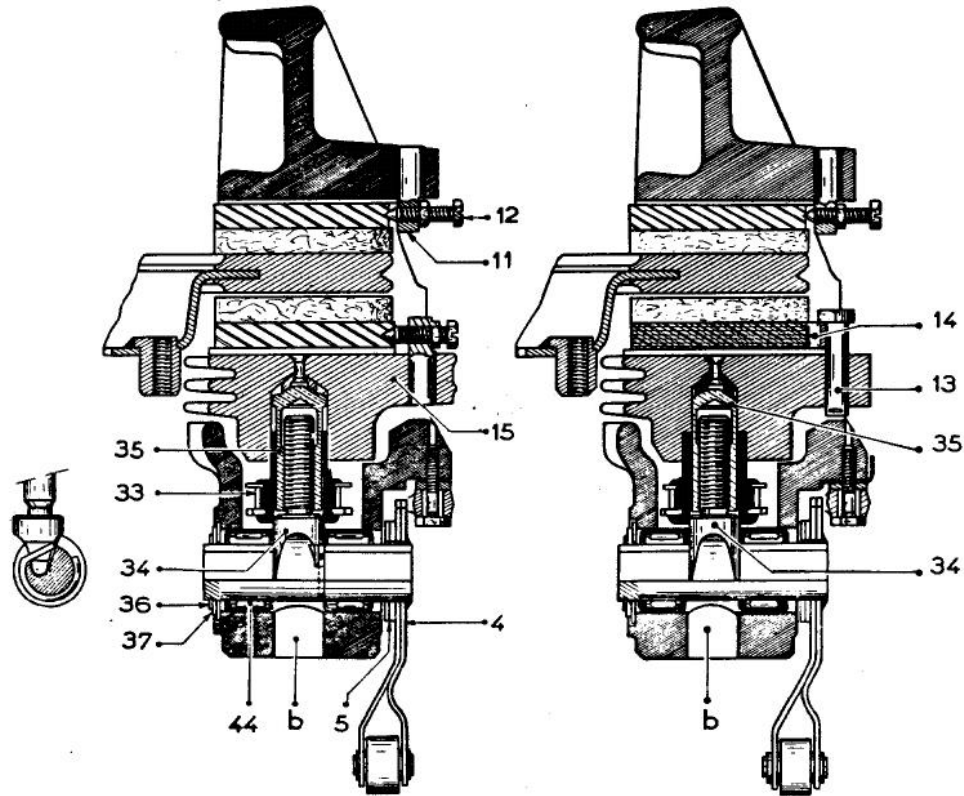

Fig. 4

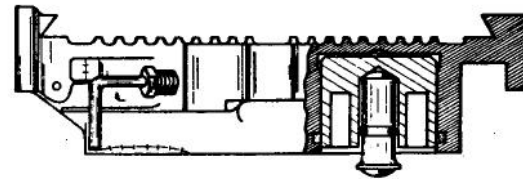
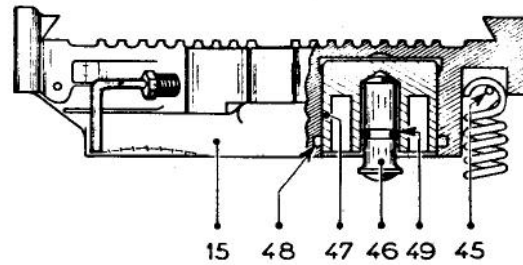

Fig. 5



TOOLS FOR BRAKES

Fig. 1 - FORK

sold under No.2126-T

Fig. 2 - LEVER

sold under No.2127-T

Fig. 4 - SPANNER

sold under No.2141-T

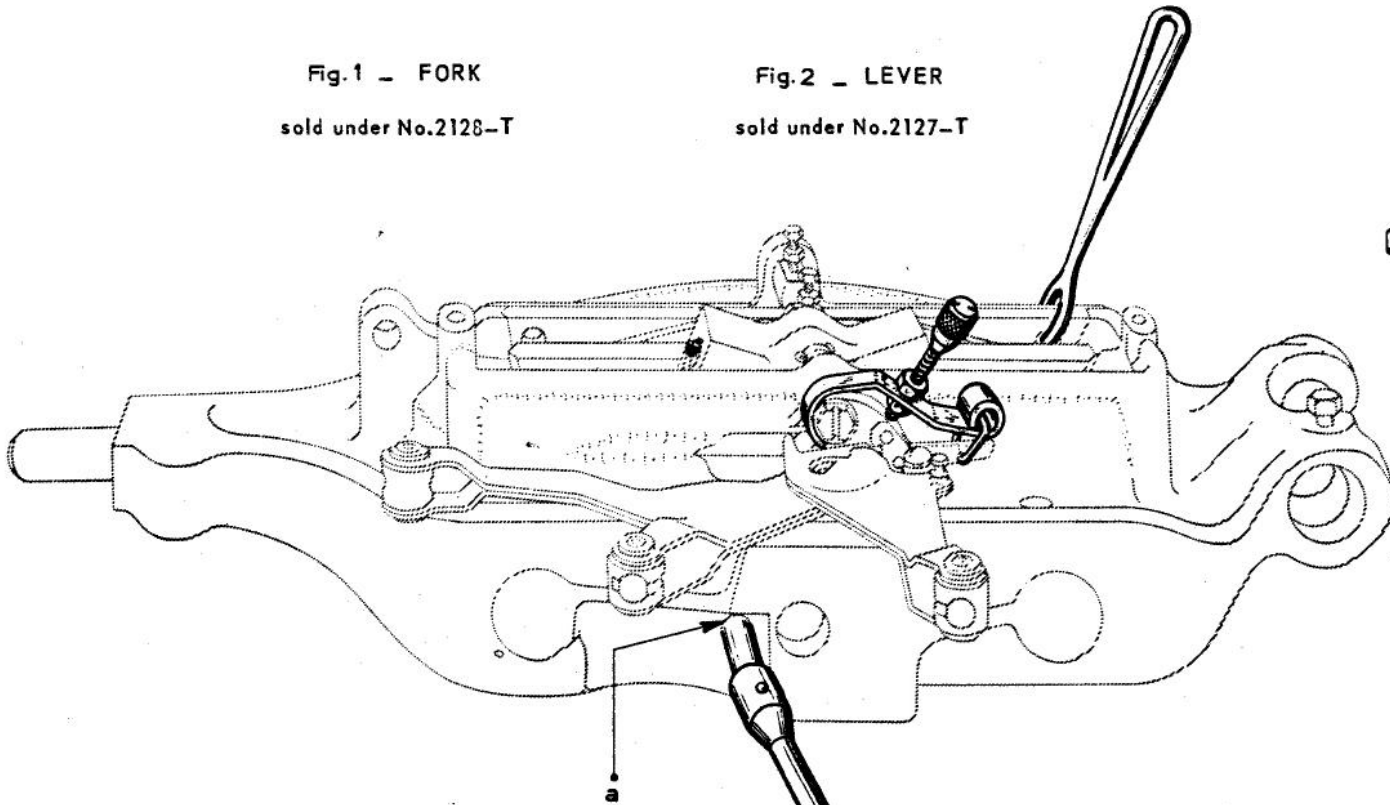
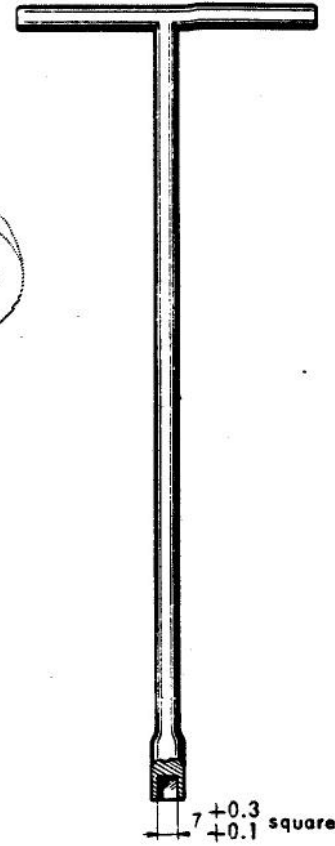
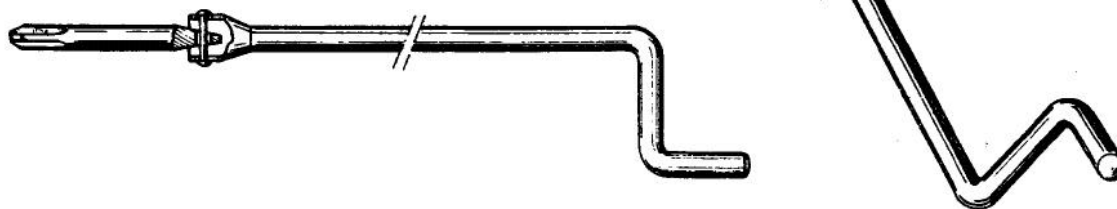

Fig. 3 - SPANNER WITH EXTENSION

sold under No.2129-T



REAR BRAKE BACKPLATE

Fig. 1

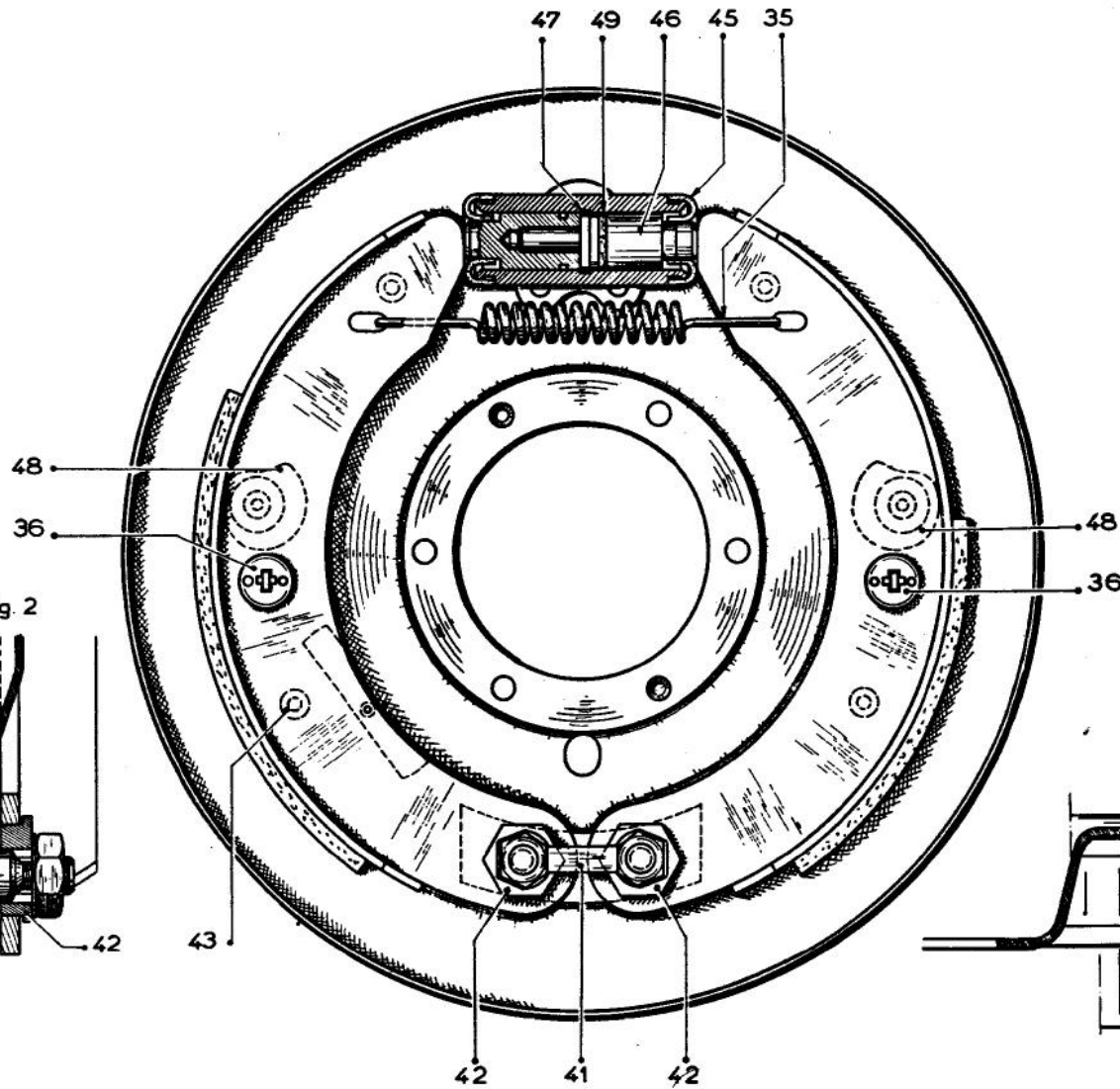

Fig. 4

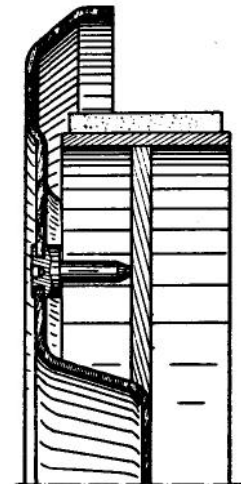

Fig. 2

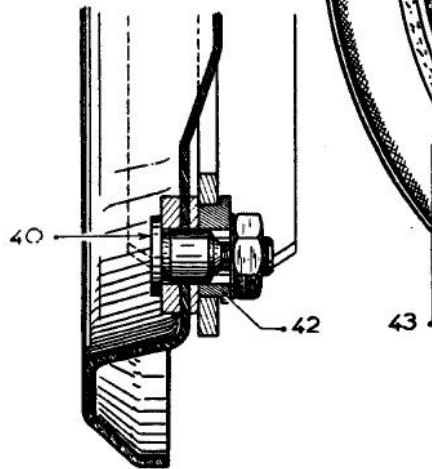
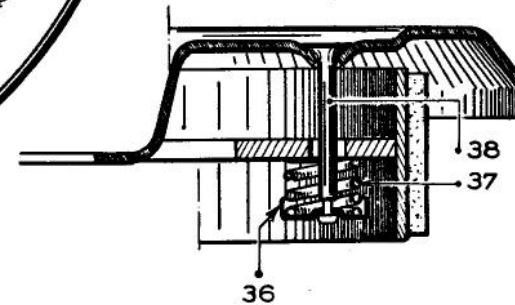

Fig. 3



# REMOVING AND FITTING THE RETURN SPRINGS

Fig. 1 - METHOD OF USING PINCERS

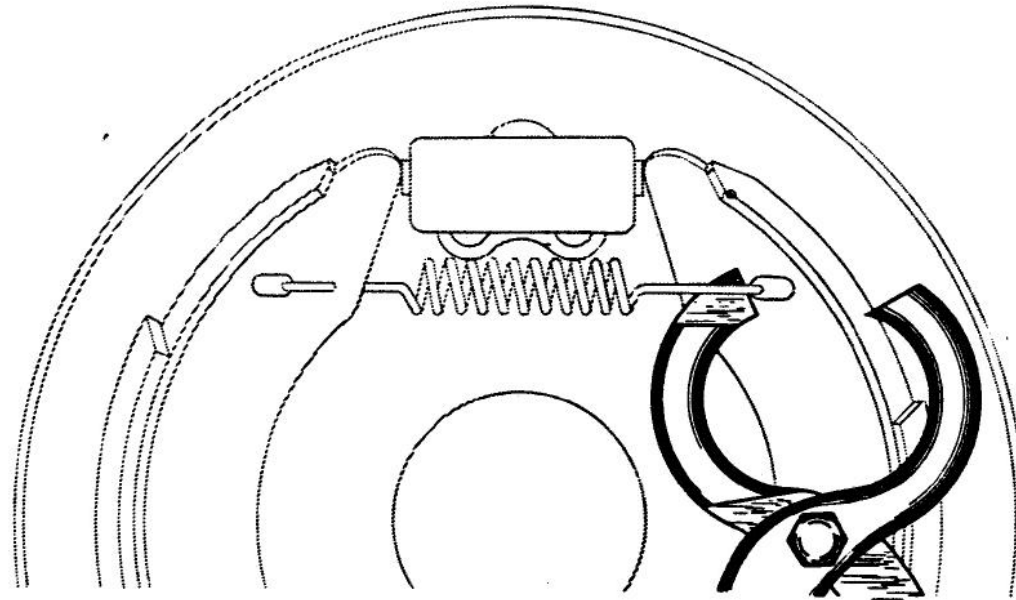
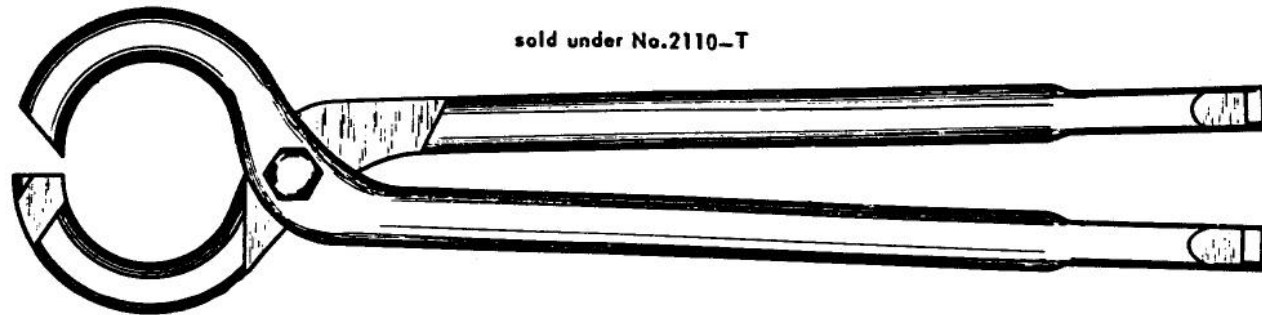

Fig. 2 - PINCERS

sold under No.2110-T





## RIVETTING THE BRAKE-CAM PINS

Fig. 1 \_ METHOD OF USE

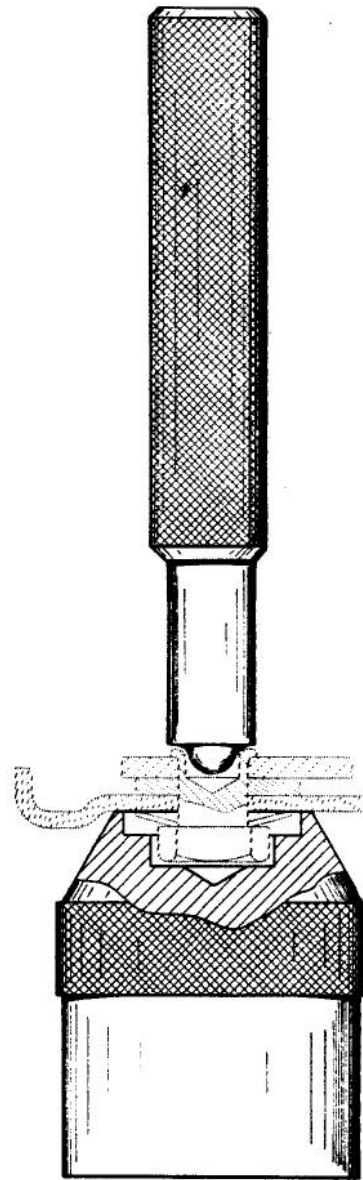

Fig. 2 \_ RIVET SET MR-3354-2

not sold

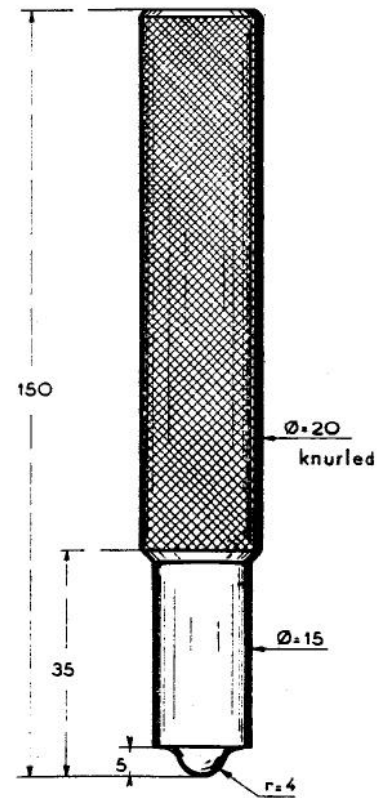
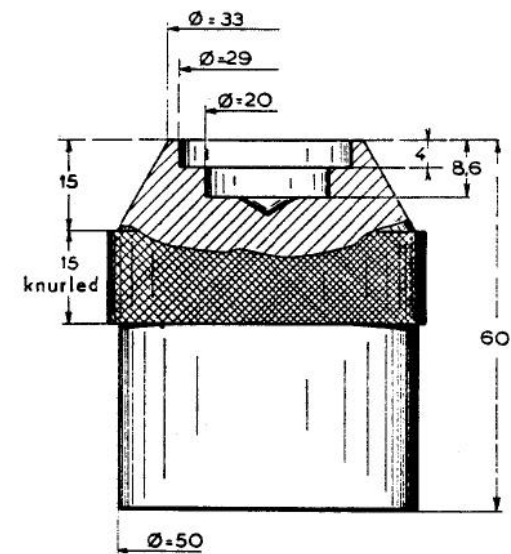

Fig. 3 \_ BLOCK MR-3354-40

not sold





## CENTRING THE BRAKE SHOES

Fig 1 \_ SETTING TO THE DIAMETER OF THE DRUM

PLACE THE GAUGE IN THE BRAKE DRUM WITH THE TWO DOWELS ENGAGED IN THE CENTRING HOLES.

TURN THE GAUGE ONE COMPLETE REVOLUTION WITH THE INDEX B HELD AGAINST THE DRUM.

TIGHTEN THE SCREW C.

GAUGE FOR INSPECTING THE CONCENTRICITY OF THE BRAKES

sold under No.2115-T

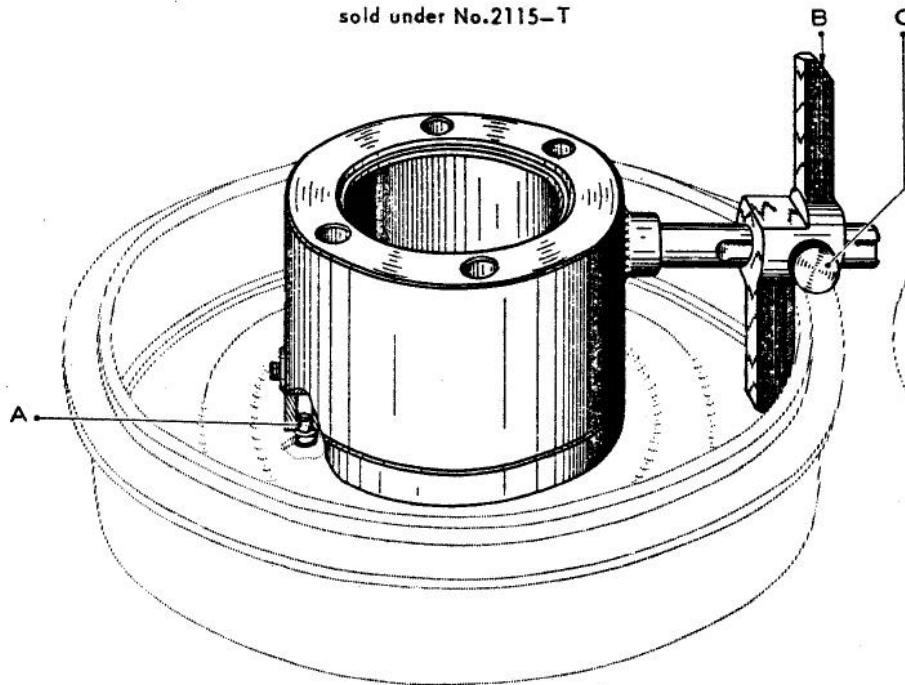
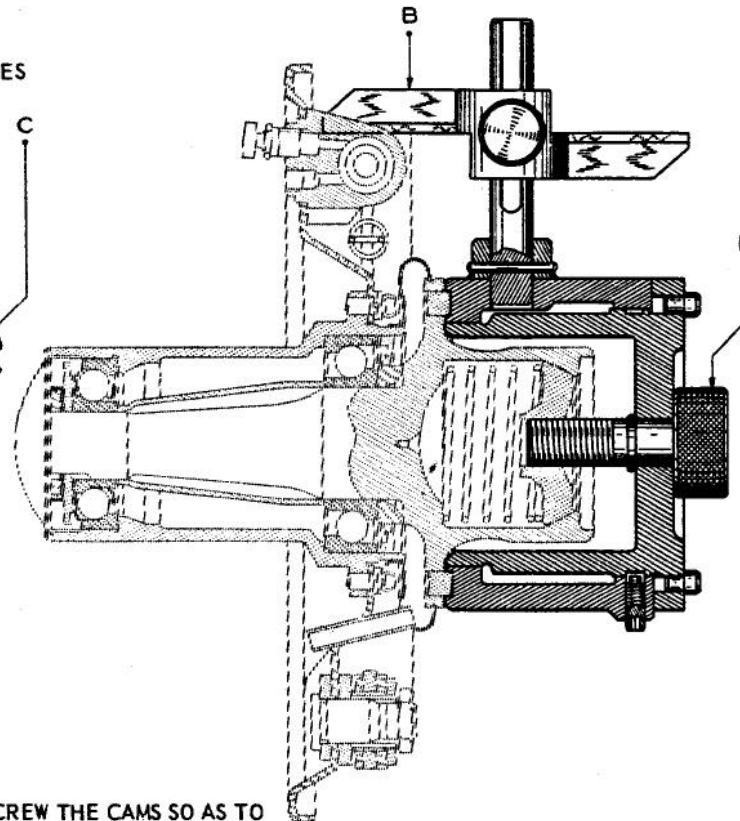

Fig. 2 \_ ADJUSTMENT OF THE BRAKE SHOES

PLACE THE GAUGE ON THE HEXAGON OF THE STUB AXLE.

TIGHTEN THE SCREW D

MOVE THE BRAKE SHOES BY MEANS OF THE ADJUSTING CAM SO THAT THE INDEX B IS LEVEL WITH THE LINING ALL THE WAY ROUND.



AFTER INSPECTION UNSCREW THE CAMS SO AS TO ALLOW THE BRAKE DRUMS TO BE FITTED.

PEDAL GEAR

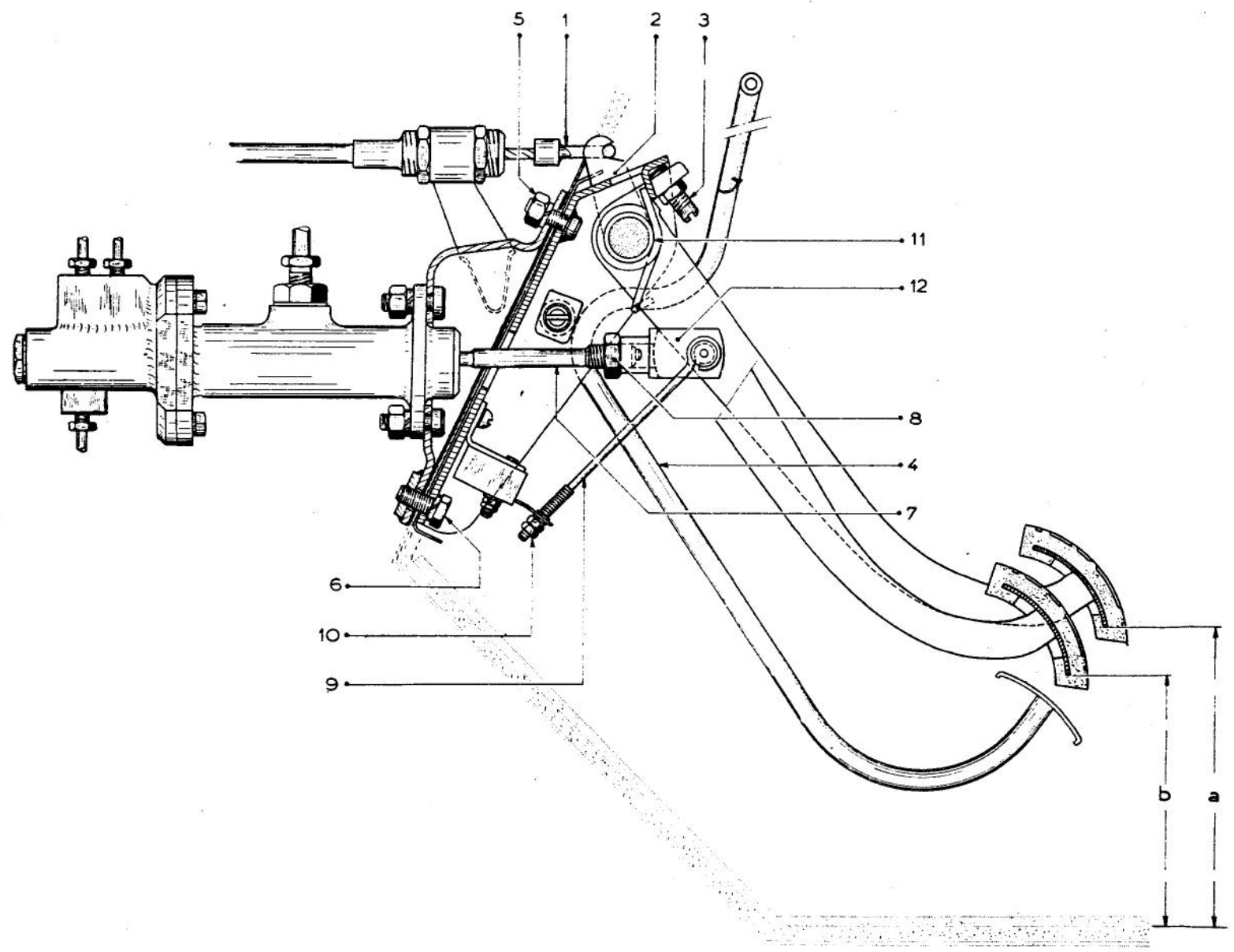

MASTER CYLINDERS

Fig. 1

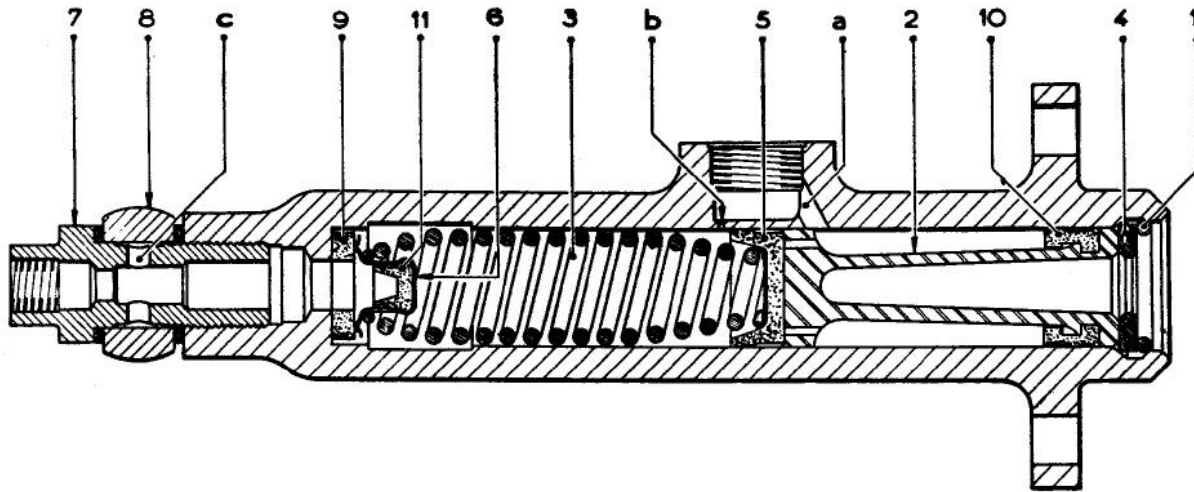
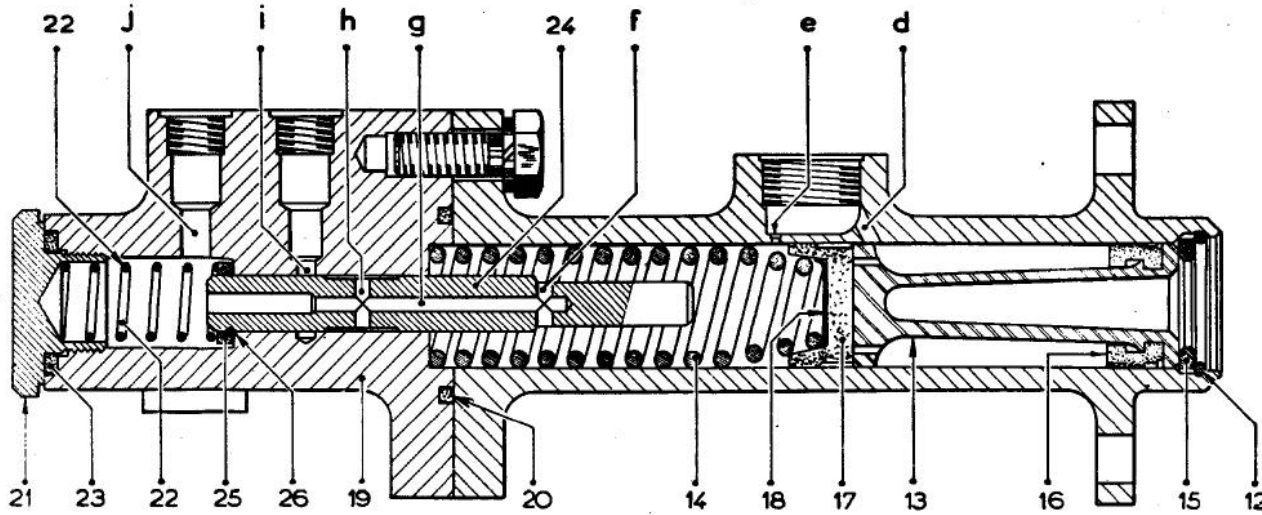
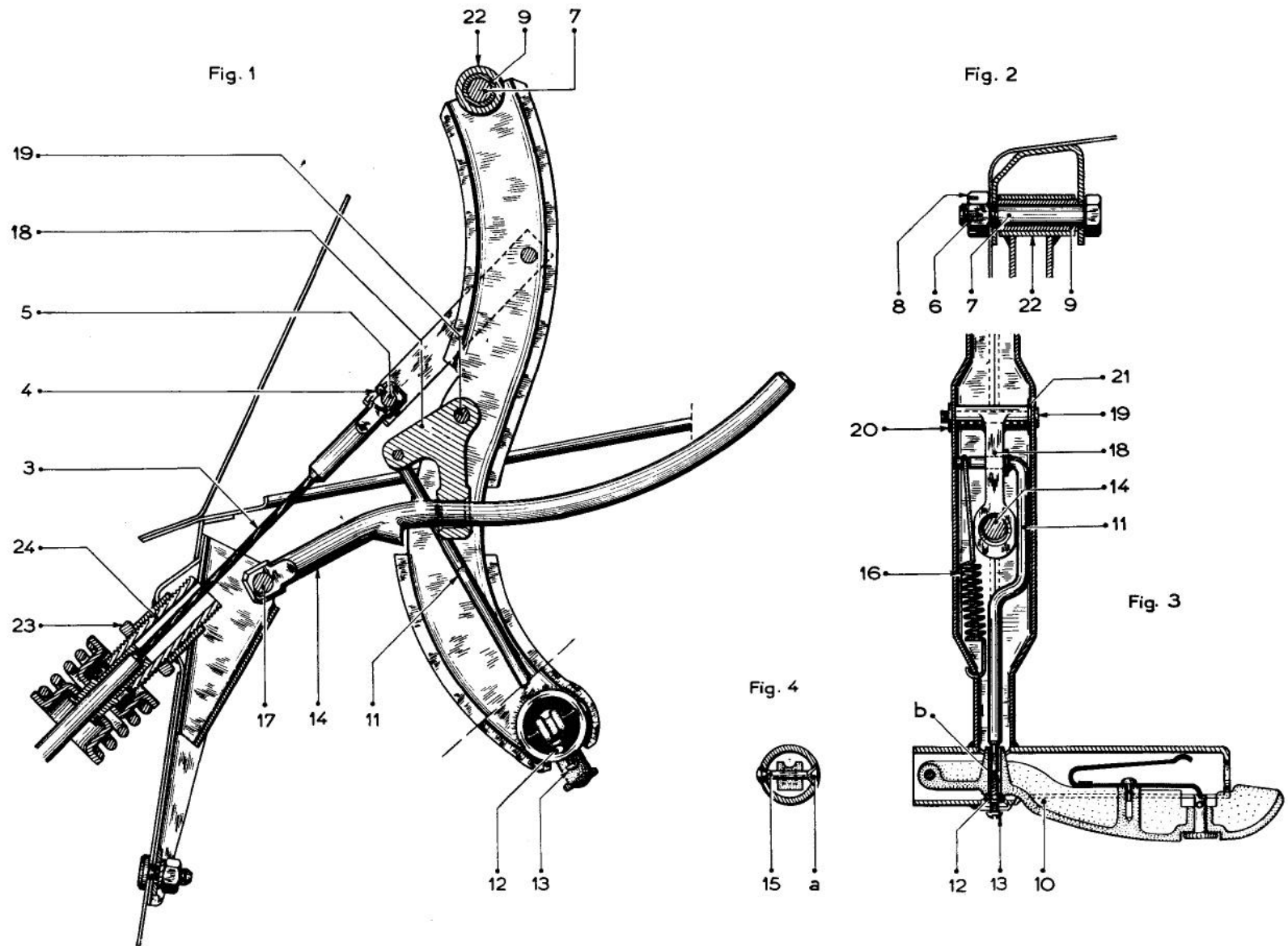

Fig. 2



PARKING BRAKE CONTROL (MECHANICAL)



CABLE ADJUSTMENT

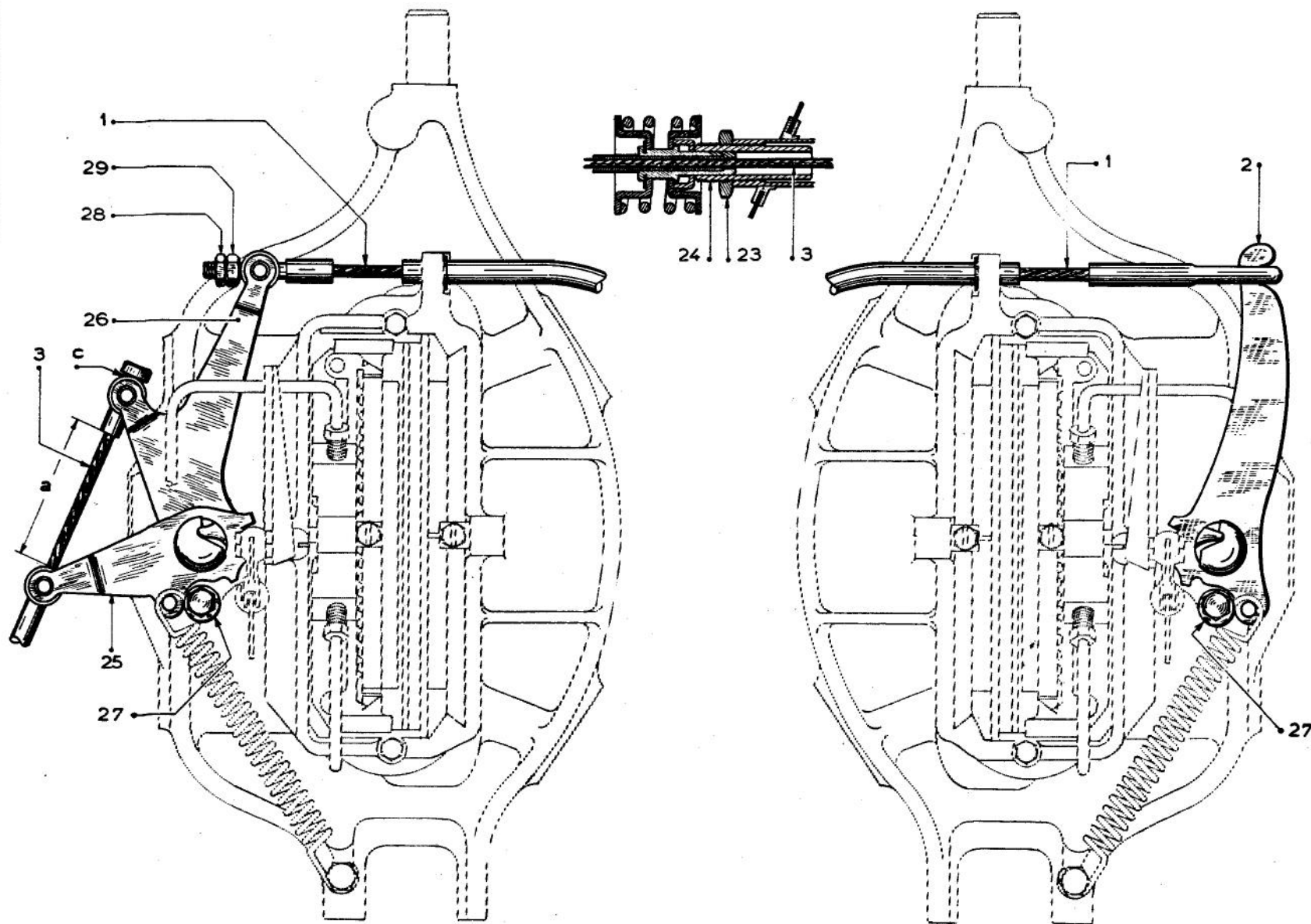

LIFTING POINTS ON THE BODY

Fig. 1 — LOCATION OF THE JACKING PAD

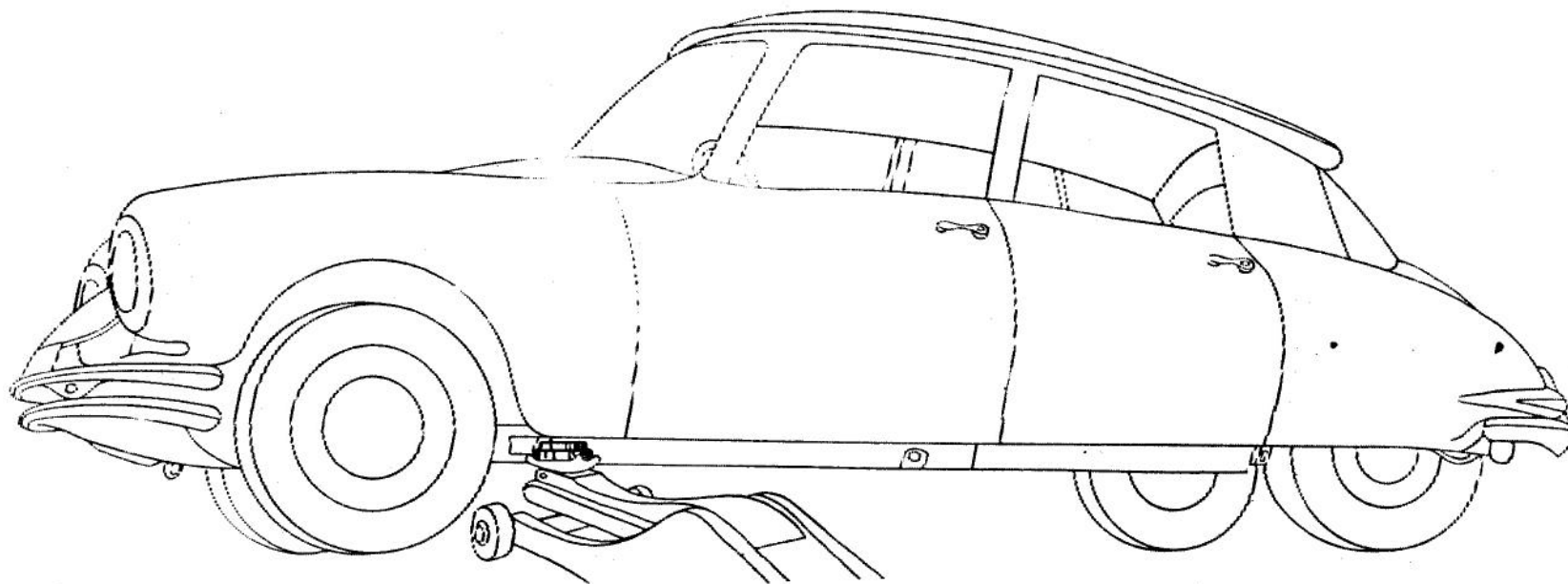
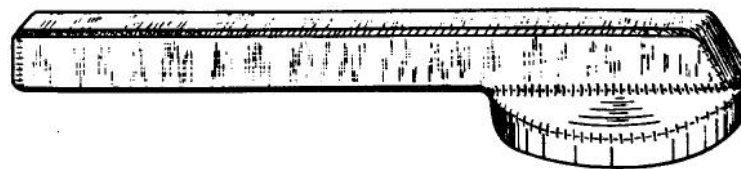

Fig. 2 — JACKING PAD

sold under No.2505-T



## CHECKING THE CAMBER

Fig. 1 — METHOD OF USING INSPECTION GAUGE

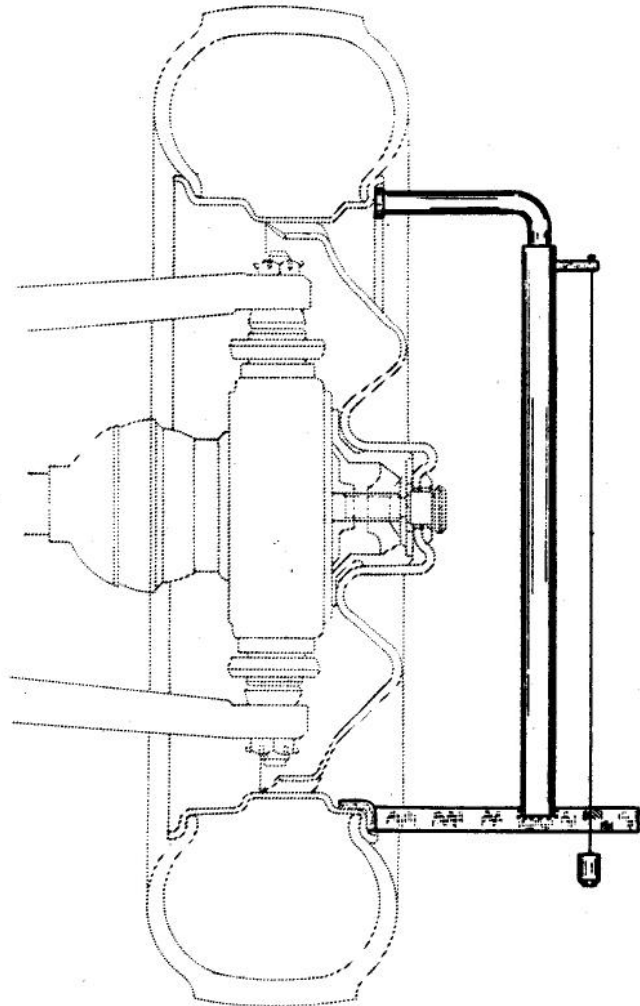
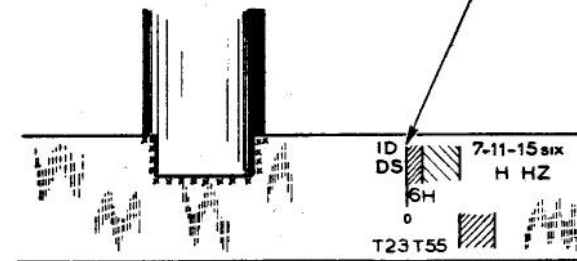

Fig. 2 — DETAILS OF GRADUATION

THE PLUMB-LINE MUST BE LEVEL WITH THIS MARK.

THE DIFFERENCE BETWEEN THE RH SIDE AND THE LH SIDE OF THE CAR MUST NOT EXCEED 1 mm.



INSPECTION GAUGE

sold under No.2314-T

PRE-ADJUSTMENT OF THE FRONT HEIGHT

GAUGE RODS

sold under No.2307-T

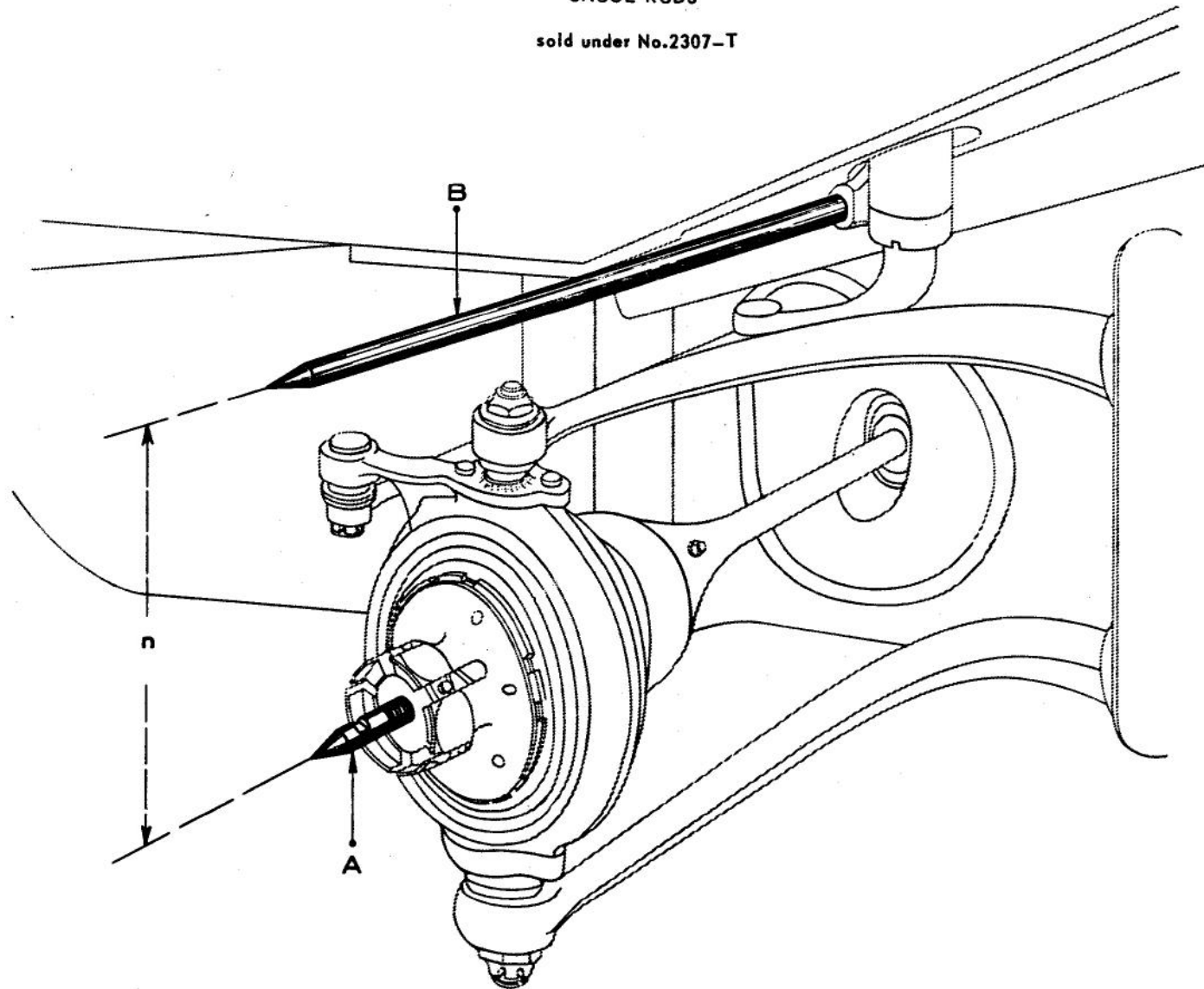



DUCELLIER DYNAMO 7158A

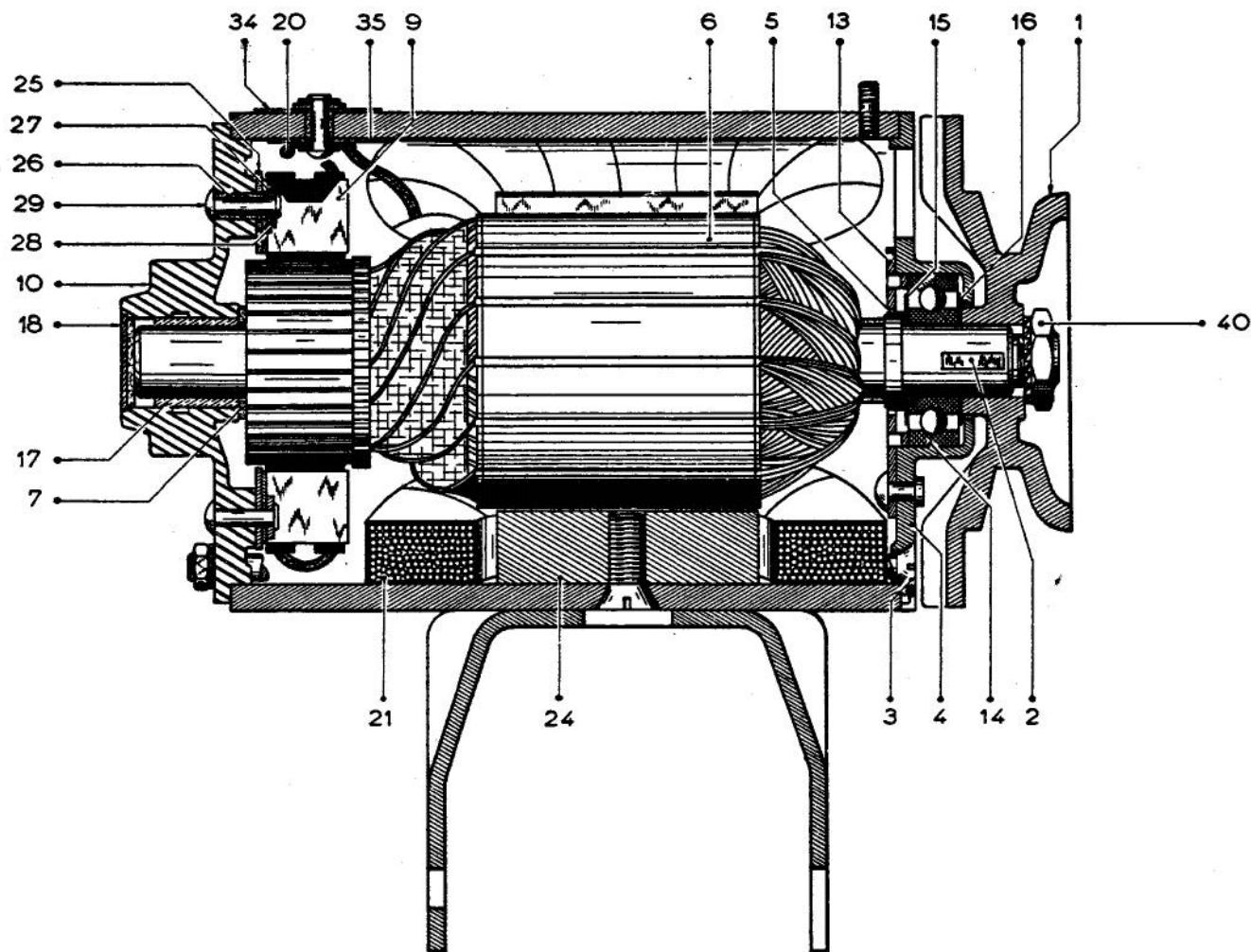

DUCELLIER DYNAMO 7158A

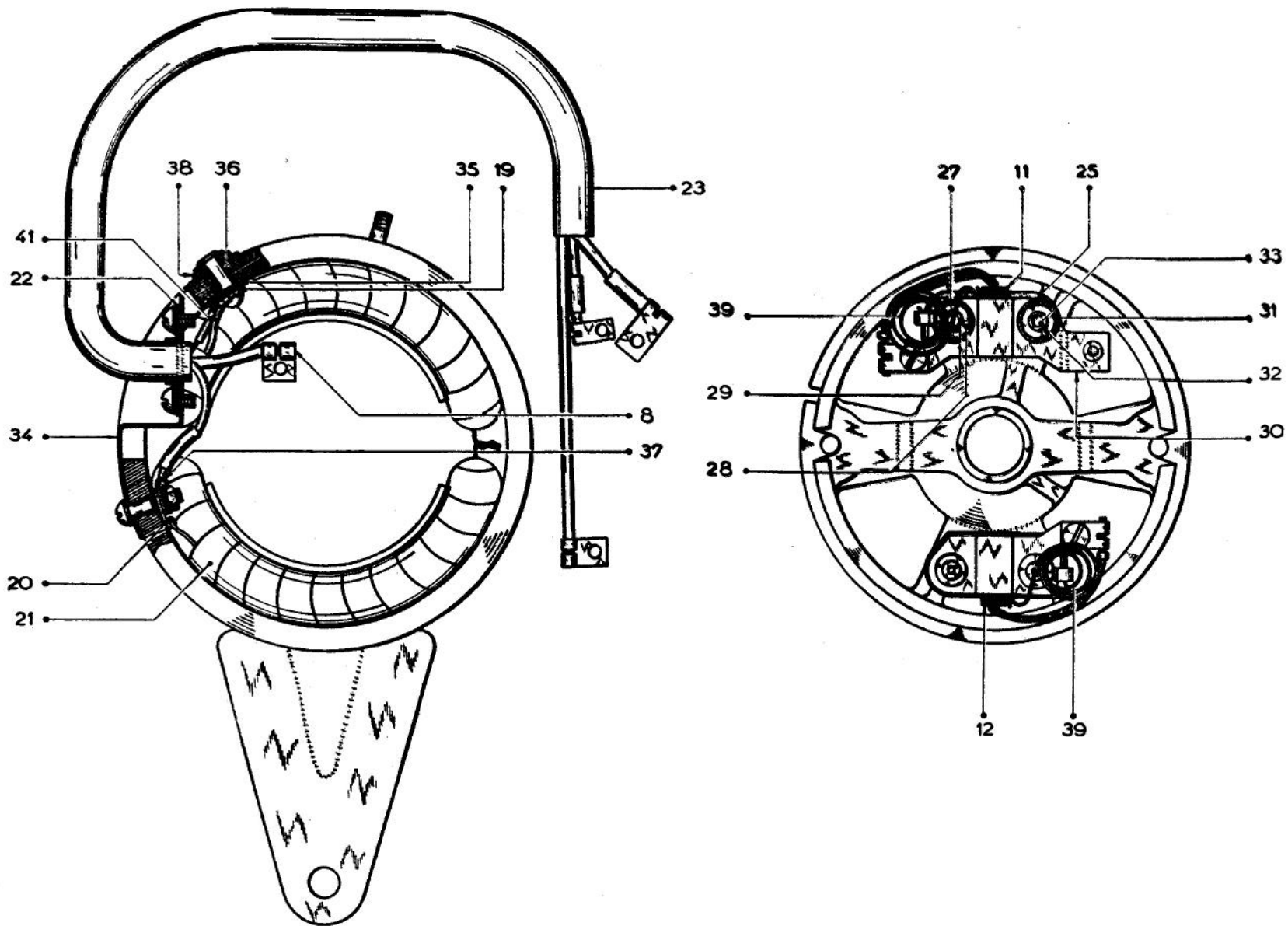

PARIS-RHONE DYNAMO G11R91

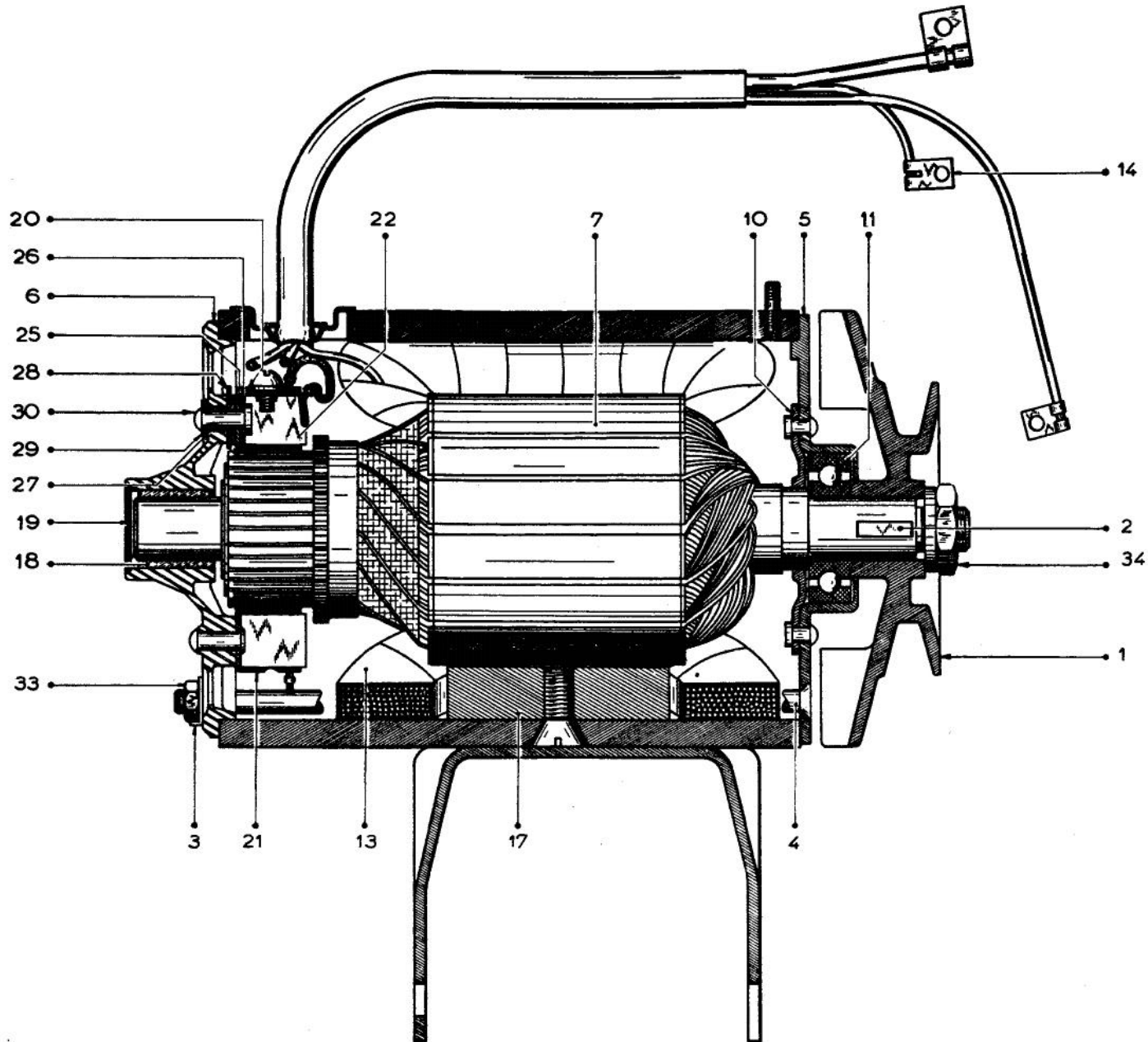

PARIS-RHONE DYNAMO G11R91

Fig. 1

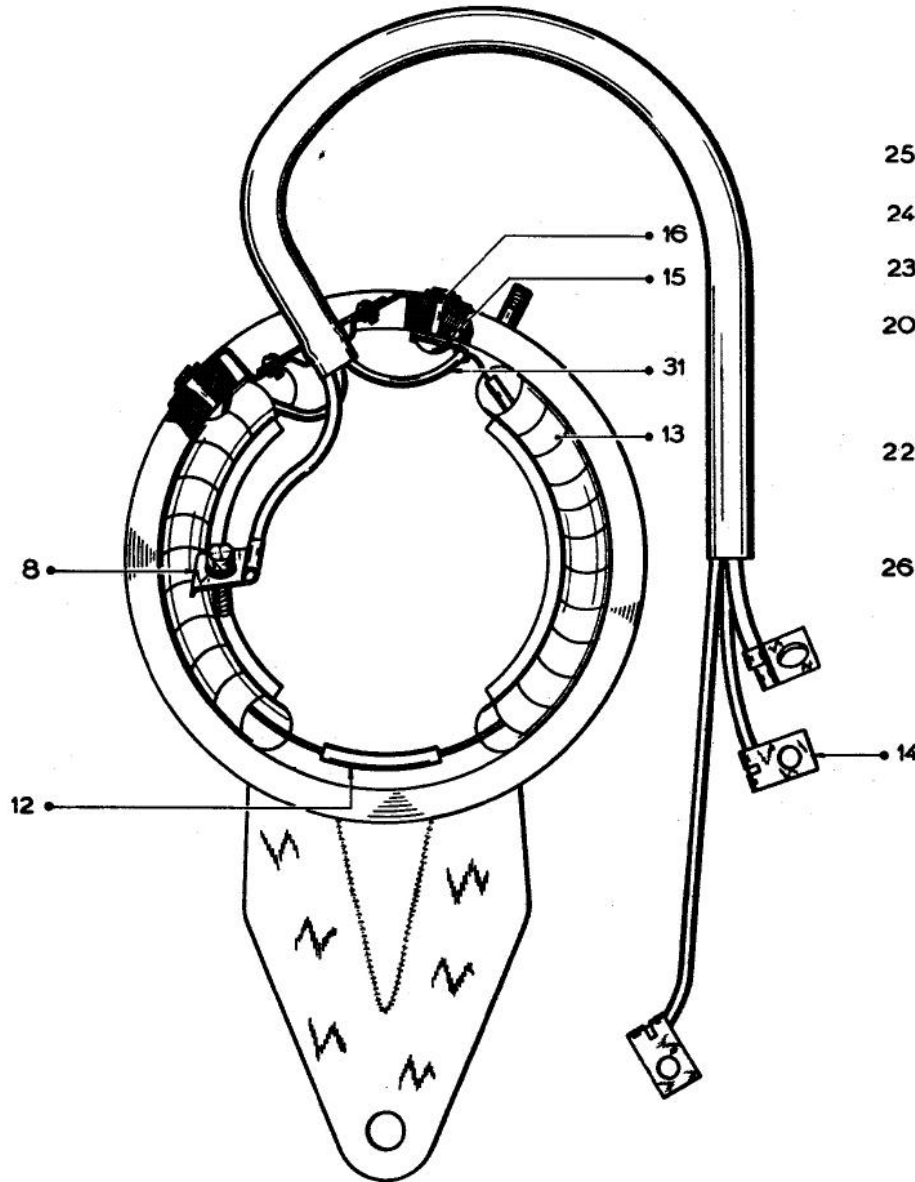
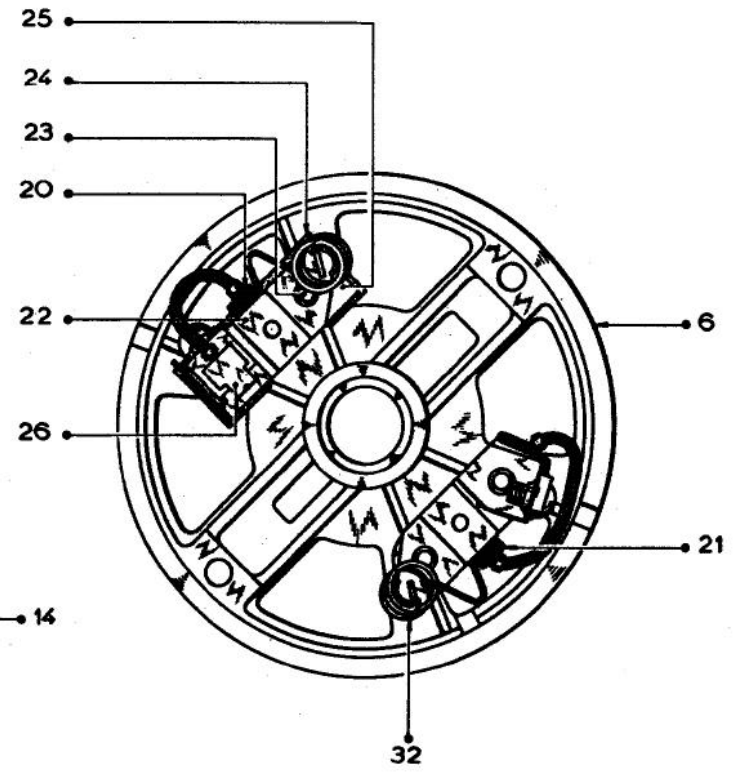
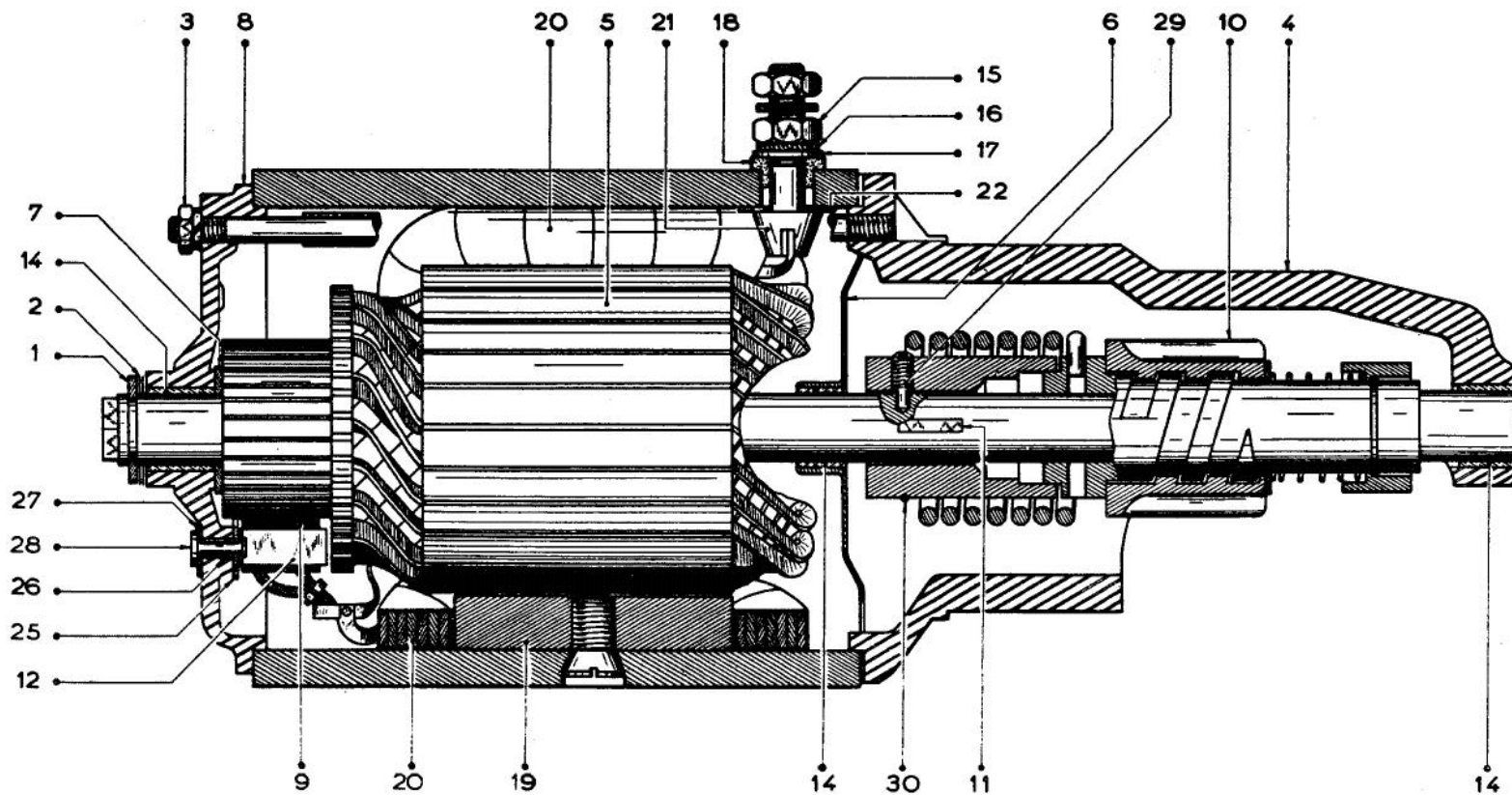

Fig. 2



DUCELLIER STARTER 6003A



# DUCELLIER STARTER 6003A

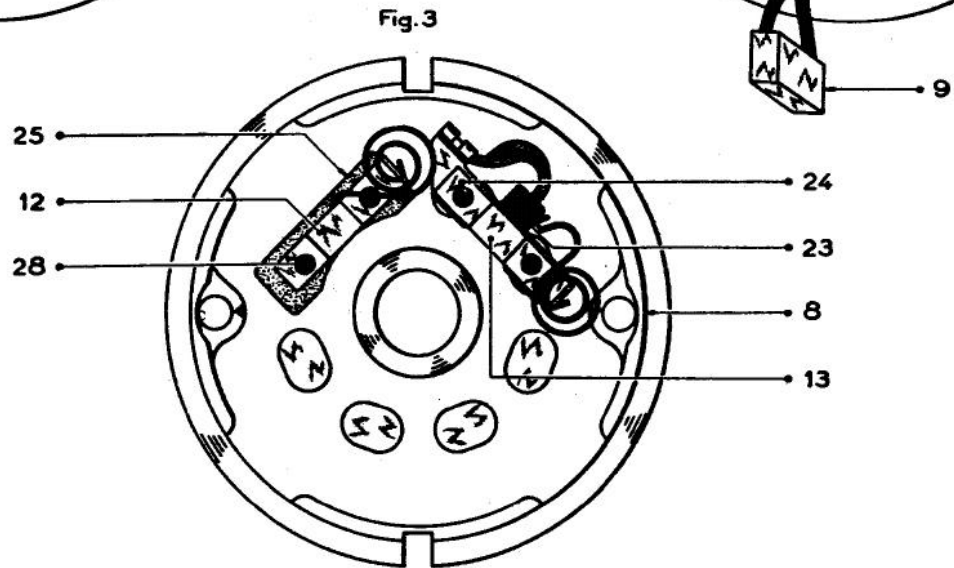
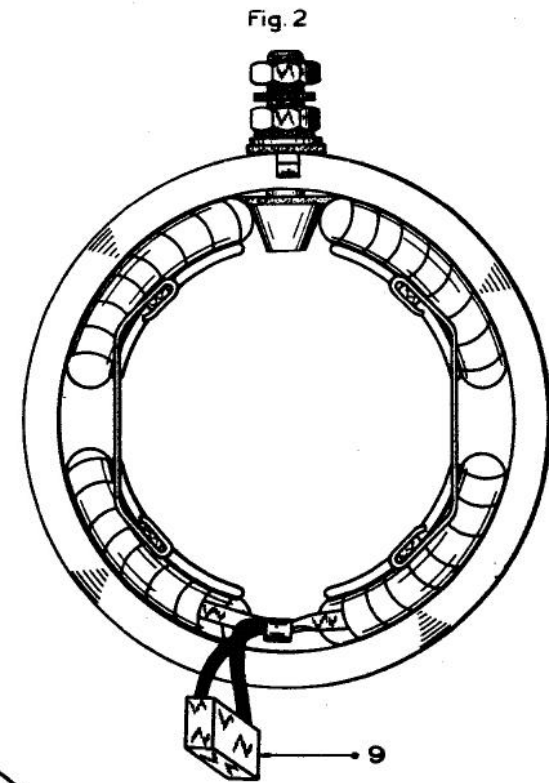
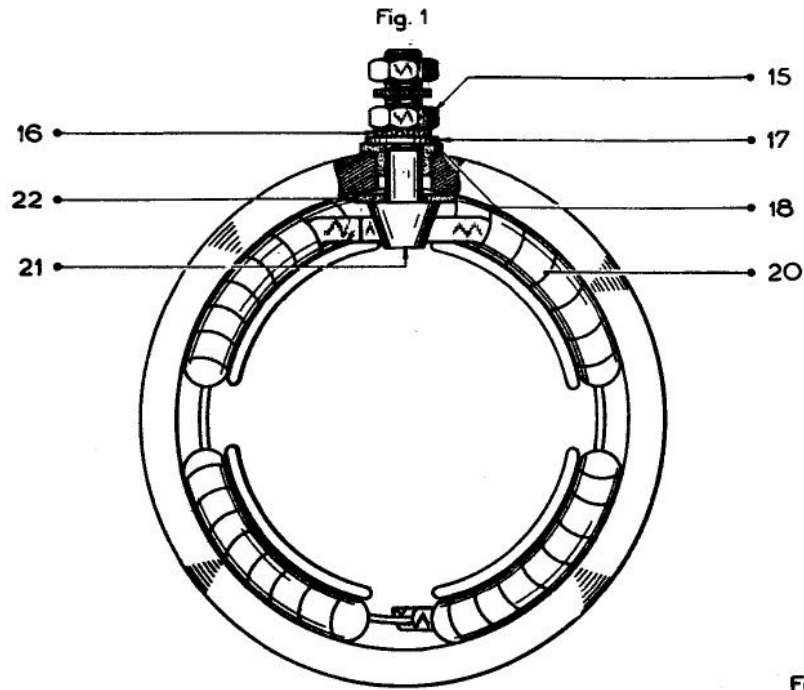

PARIS-RHONE STARTER D11B42

120

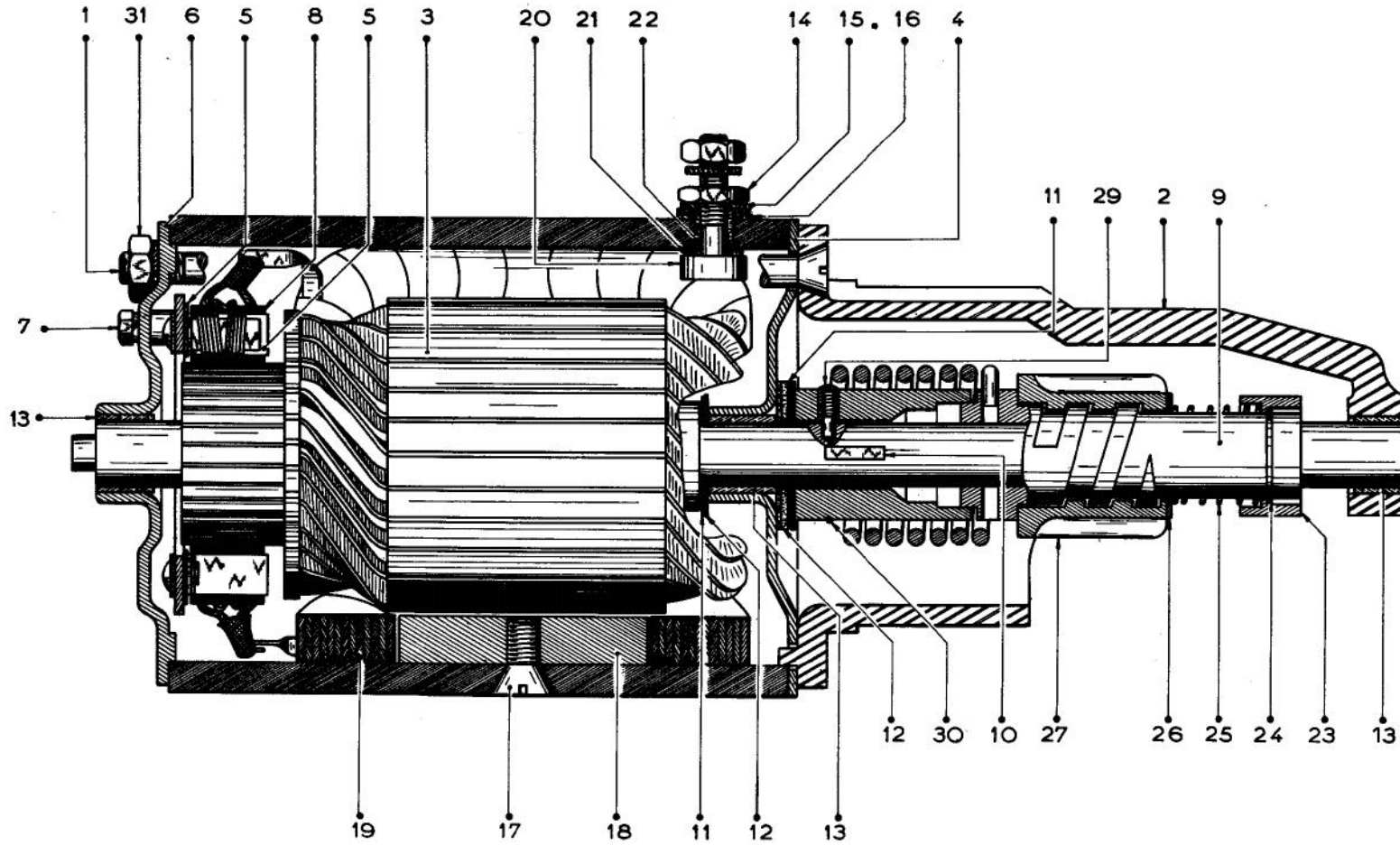

PARIS-RHONE STARTER D11B42

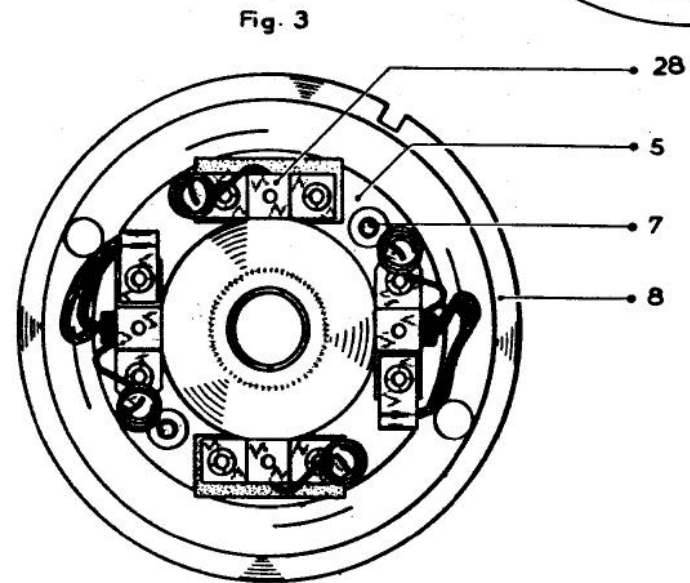
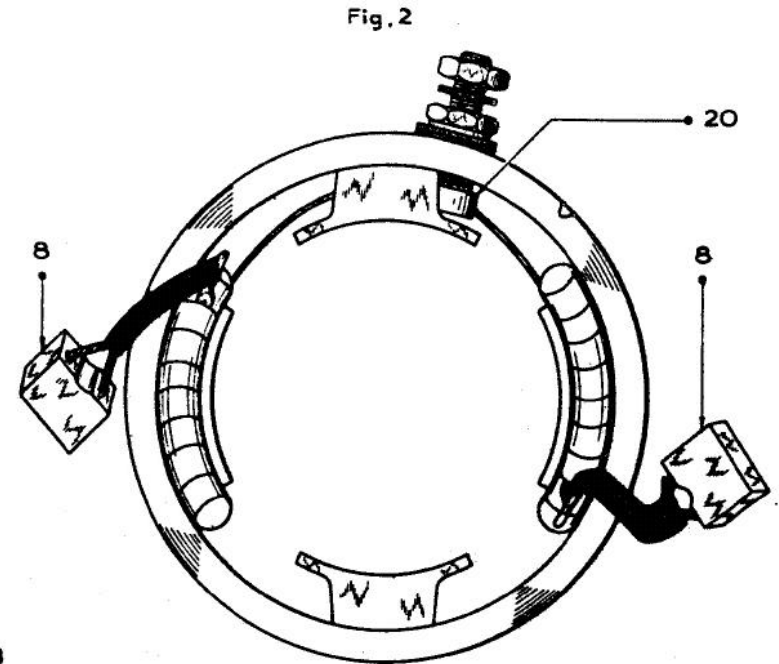
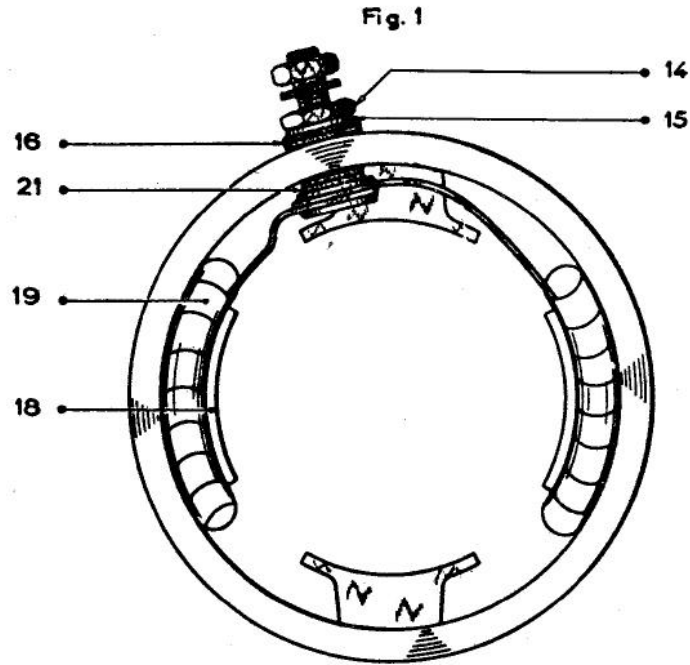



# BENADA PINION

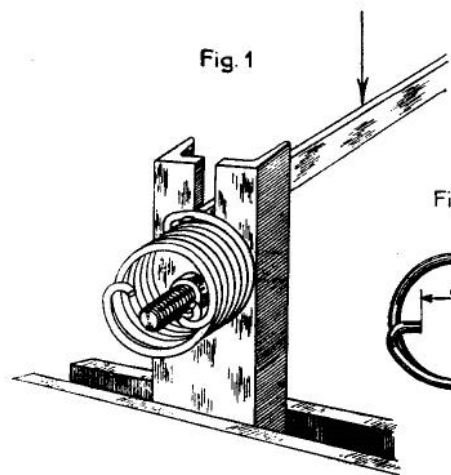

Fig. 1

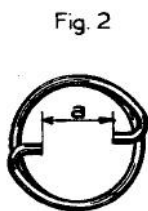

Fig. 2

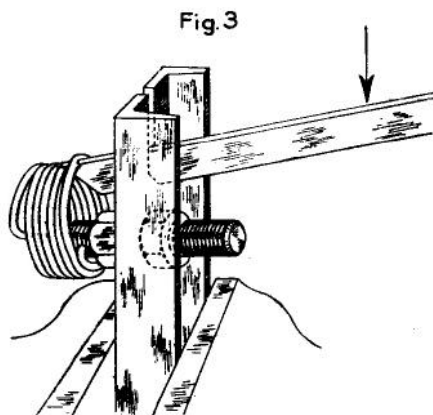

Fig. 3

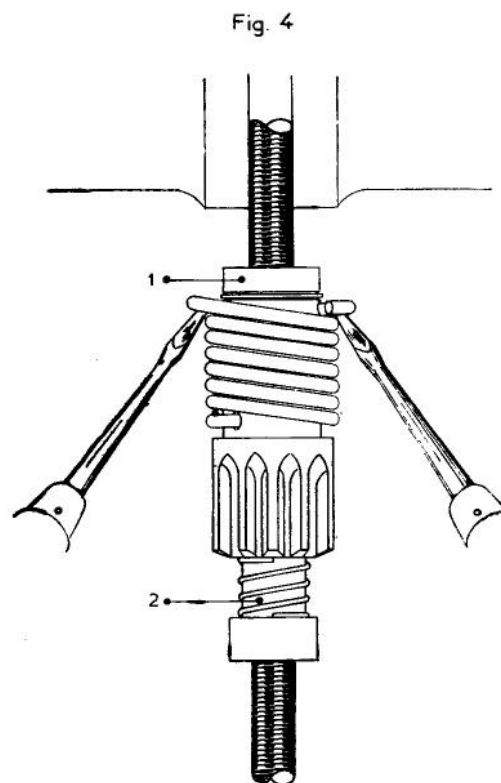

Fig. 4

Fig. 6 — SUPPORT MR-3526-13

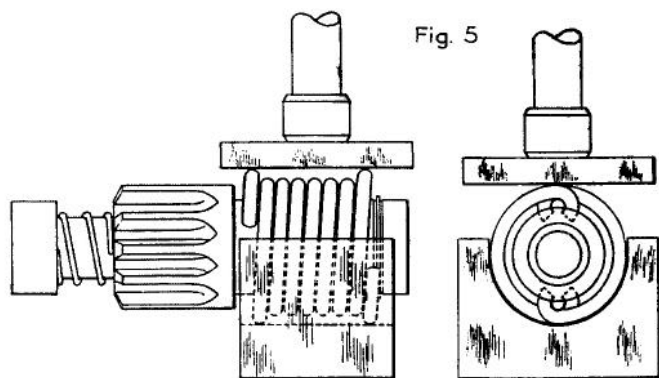
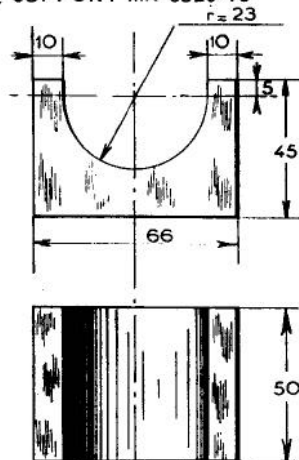

Fig. 5

Fig. 8 — SUPPORT MR-3526-11  
not sold

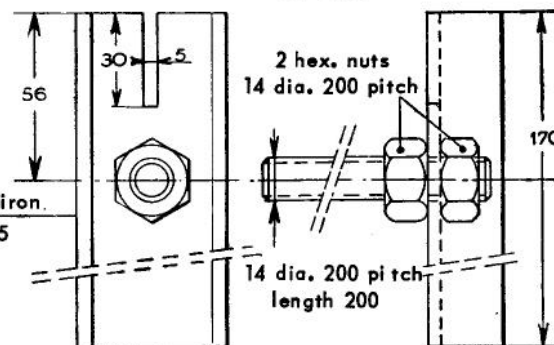
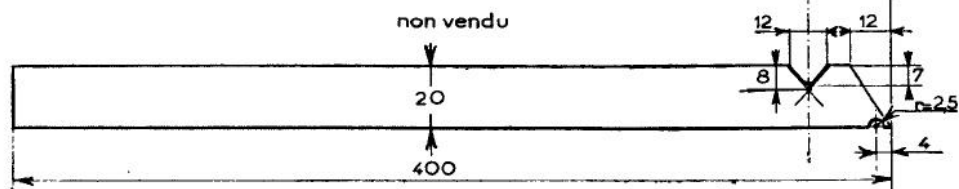

Fig. 7 — LEVER MR-3526-12



channel iron.  
50 x 25

## ASSEMBLY OF THE FIELD COILS AND POLE-PIECES

Fig. 1\_ FORMING THE COILS

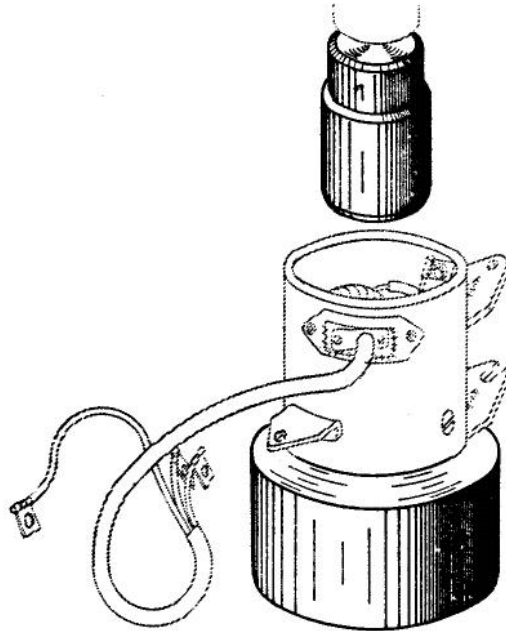
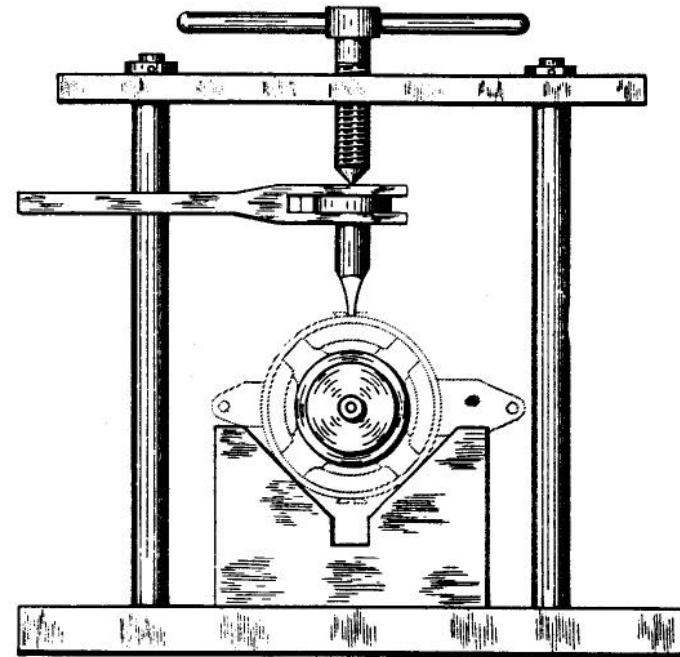

Fig. 2\_ FITTING THE POLE-PIECES



MR\_1601.1 MR\_1601.2

MR\_1601.3

MR\_1601.4

		Paris-Rhone	Ducellier
Starter	A	$\phi = 76,8^{+0,15}_{-0,10}$	$\phi = 74,4^{+0,15}_{-0,10}$
Dynamo	B	$\phi = 72,5$	$\phi = 68,5$
	C	$\phi = 69$	$\phi = 65$

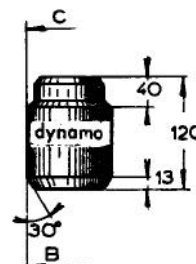
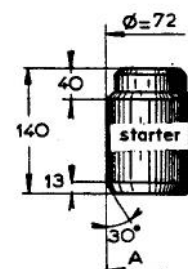

tools not sold

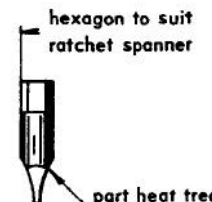
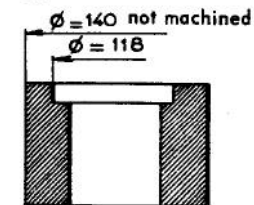

mild steel case-hardened and ground

WIRING DIAGRAM

FRONT HARNESS

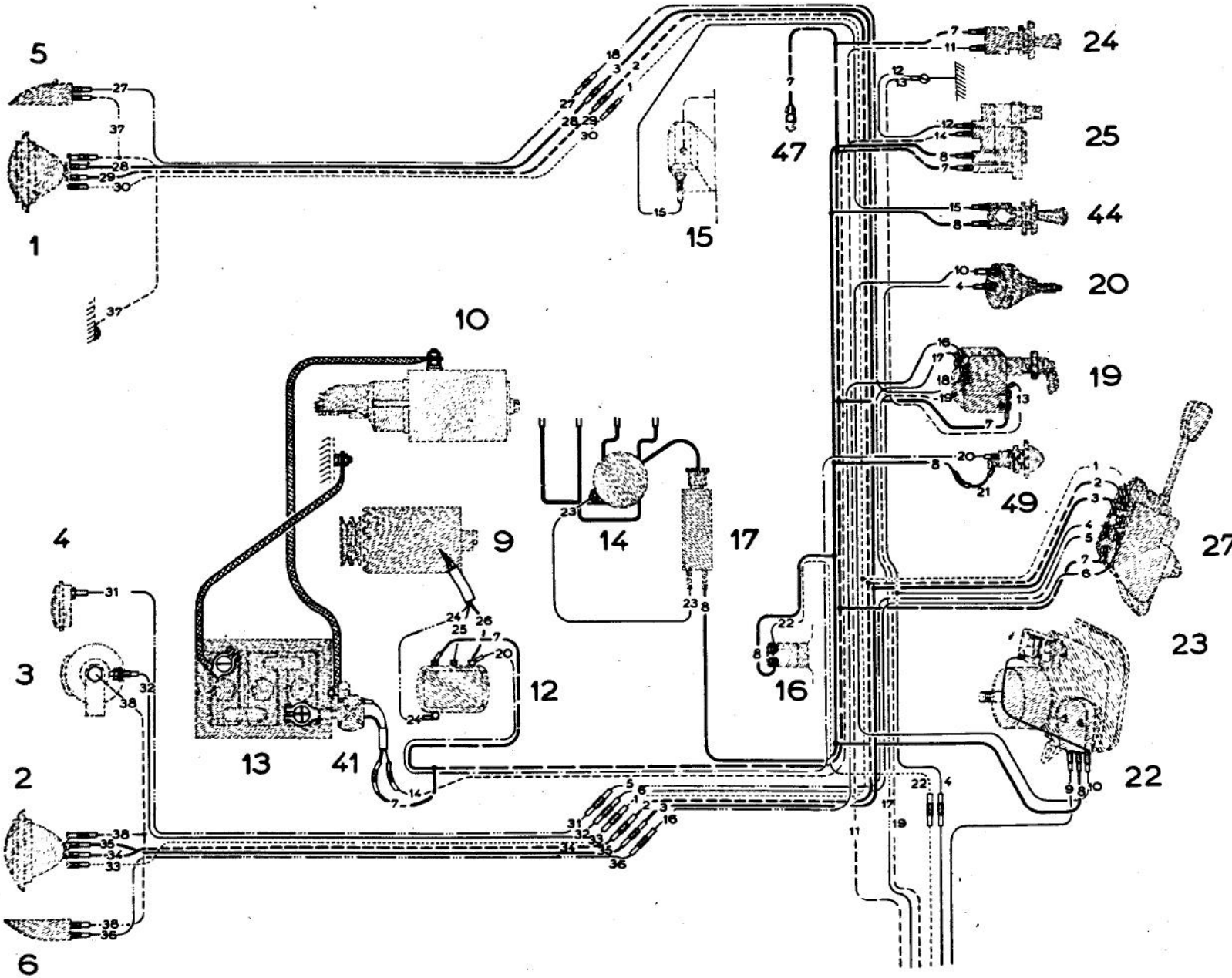

ELECTRICAL  
WIRING DIAGRAM

REAR HARNESS

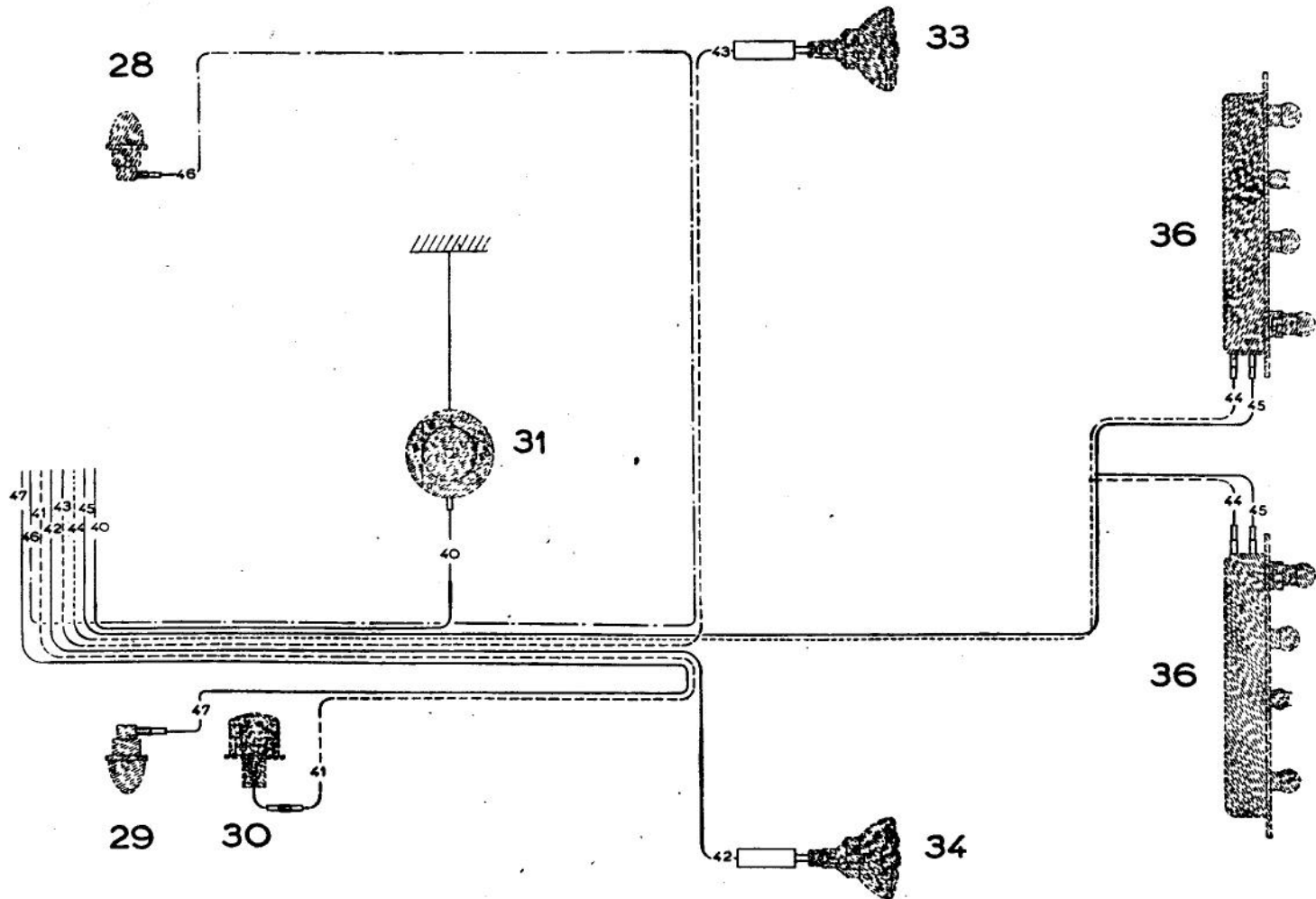

## TEST BENCH

125

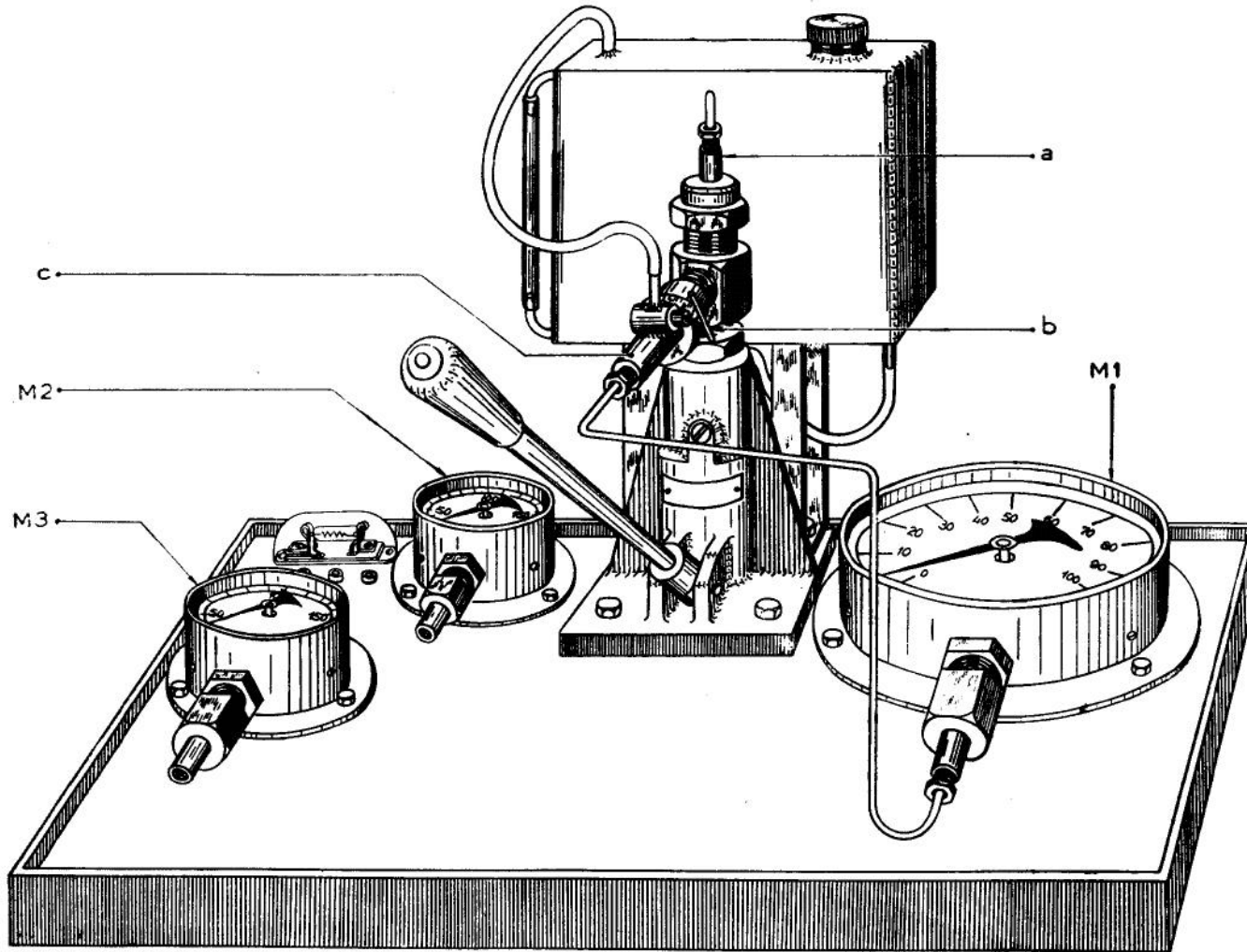
CONNECTION OF THE 1500 P.S.I. (100 kg/cm<sup>2</sup>) GAUGE

## TEST BENCH

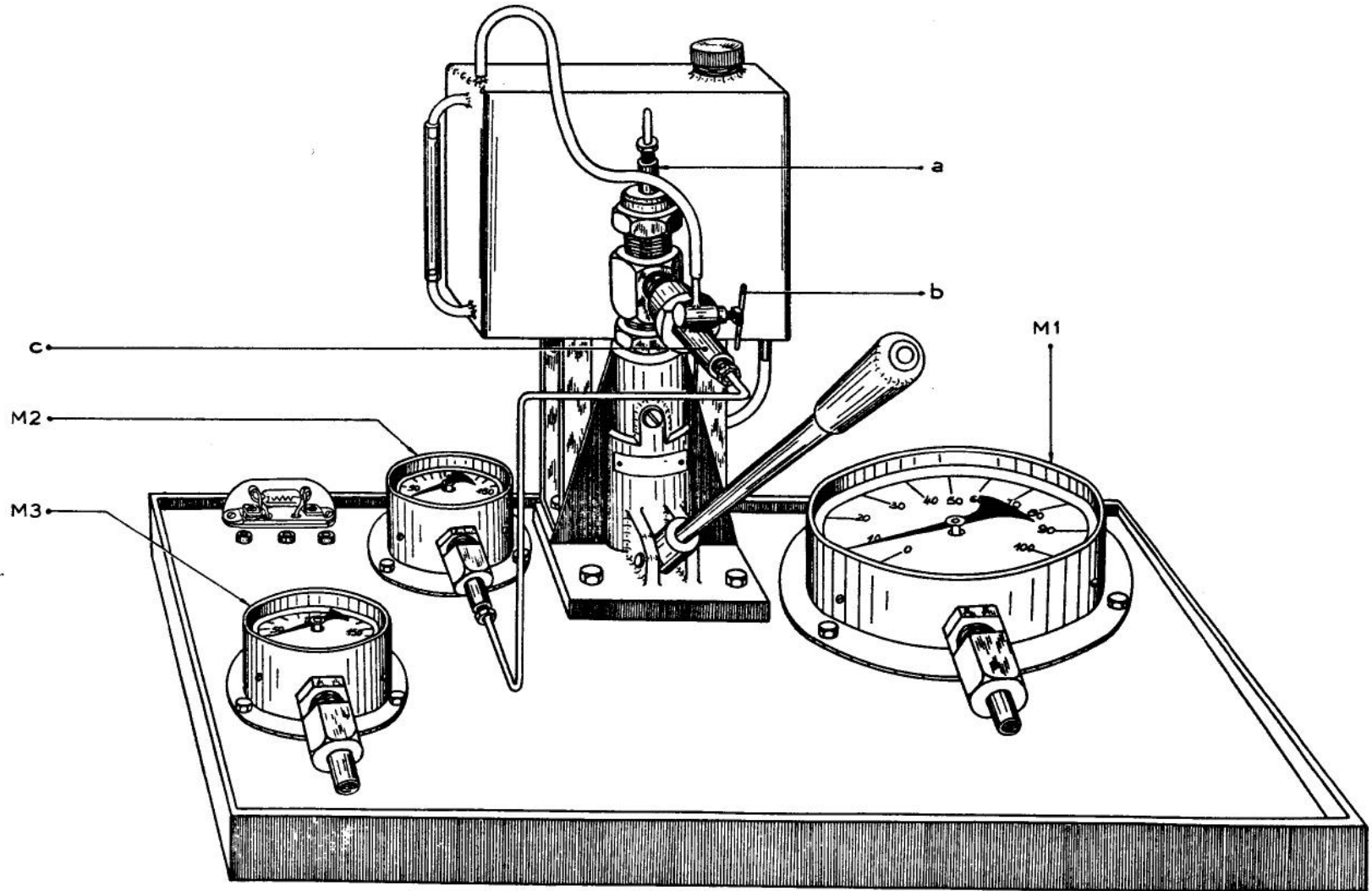
CONNECTION OF THE 3000 P.S.I. (200 kg/cm<sup>2</sup>) GAUGE

TEST PIPES AND UNIONS

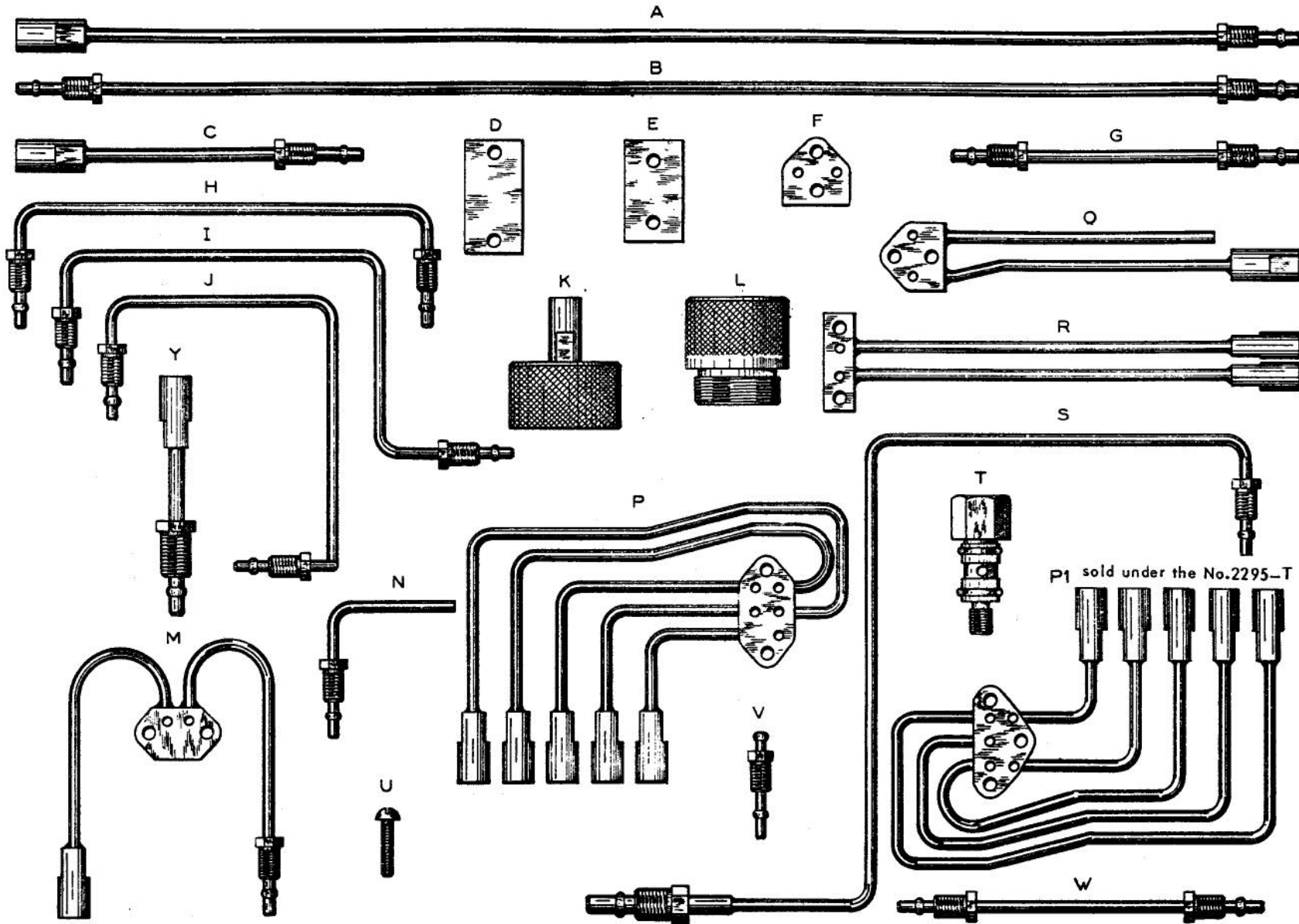

# HIGH PRESSURE PUMP

## INSPECTION FOR LEAKAGE

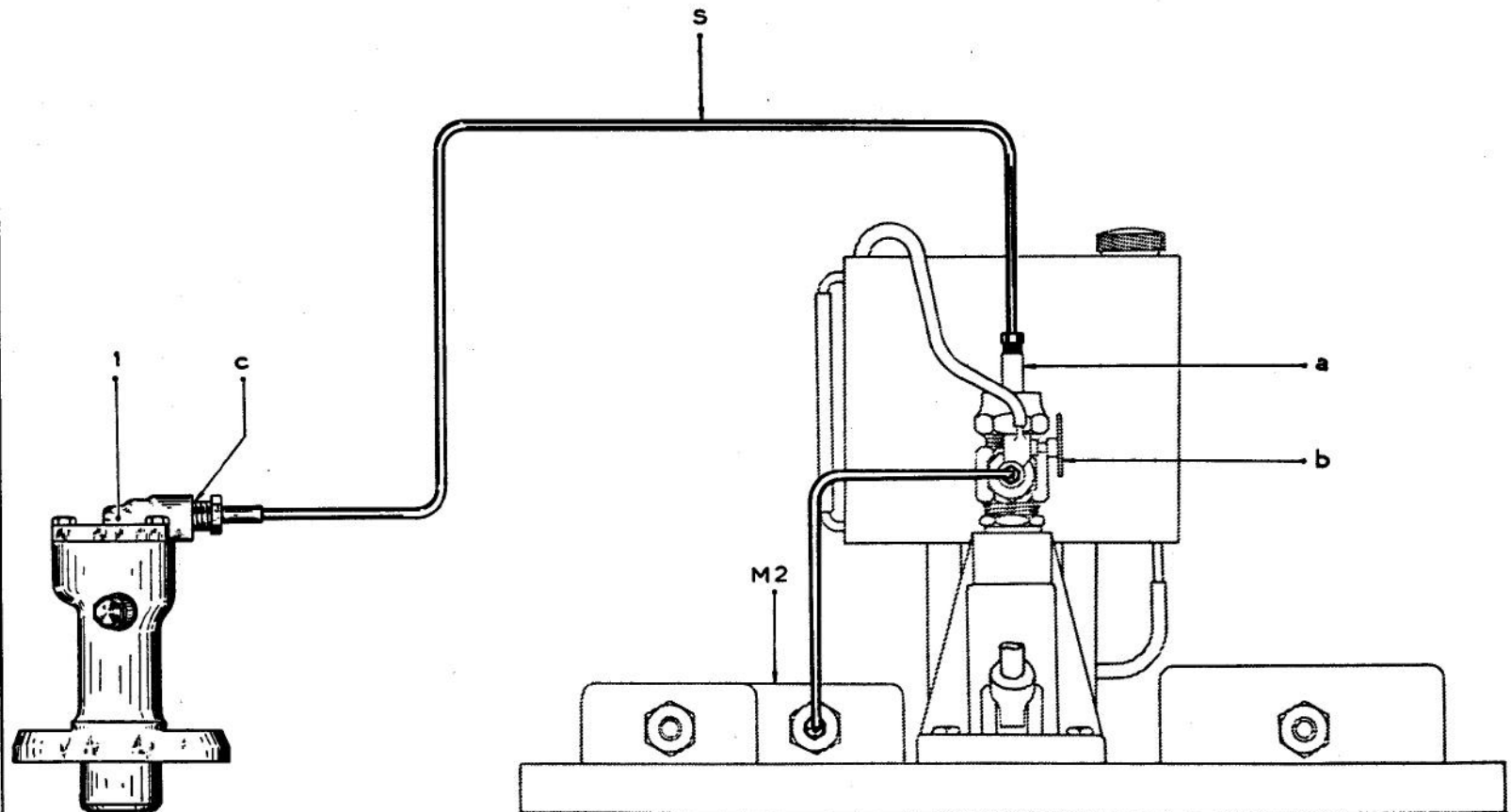



# PRESSURE CONTROL VALVE

INSPECTION OF THE CUTTING-IN AND CUTTING-OUT PRESSURES AND FOR LEAKAGE

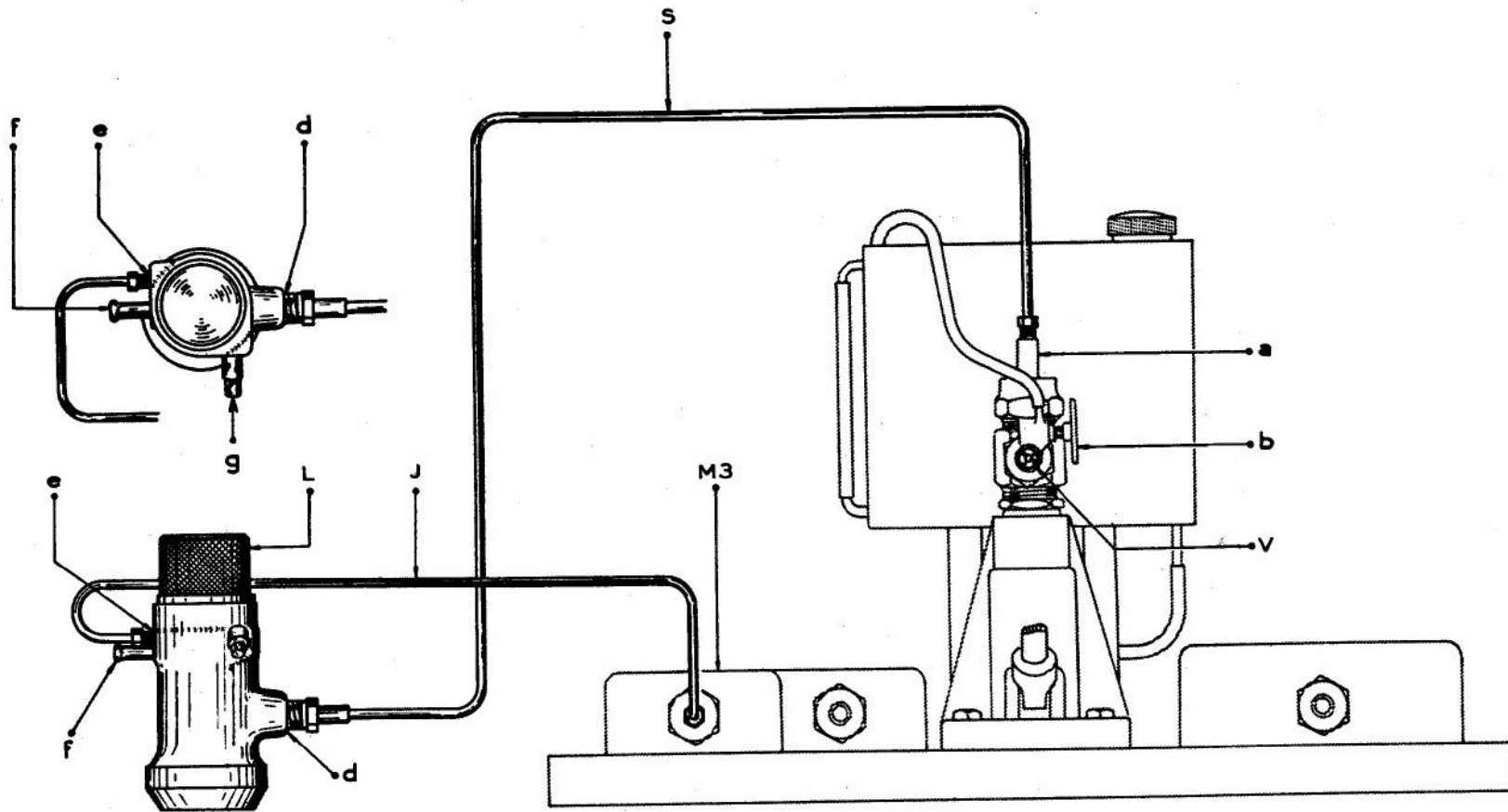

# PRESSURE DISTRIBUTION BLOCK

INSPECTION FOR LEAKAGE

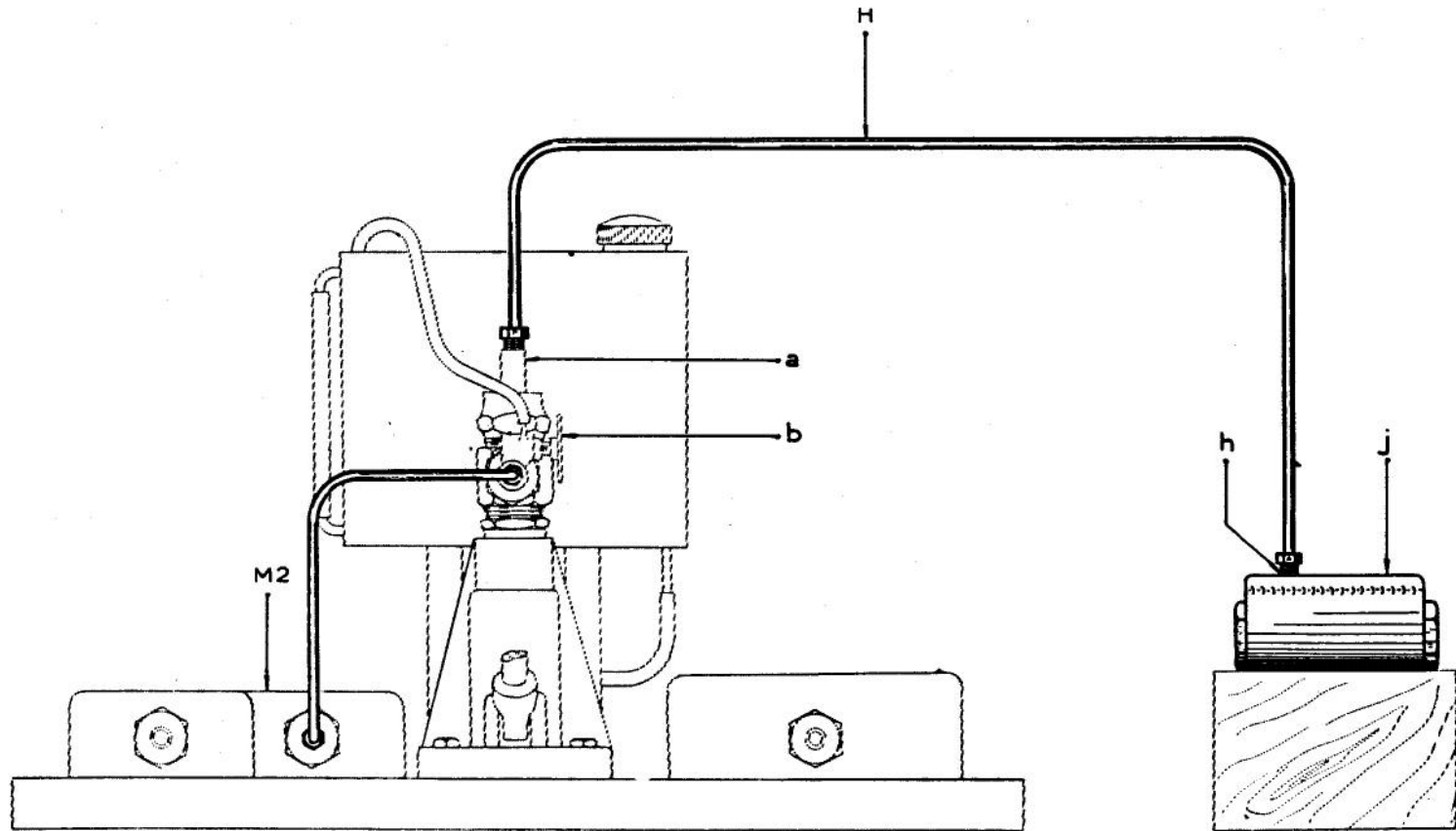

# PRESSURE DISTRIBUTION BLOCK

131

INSPECTION OF THE VALVE SETTINGS

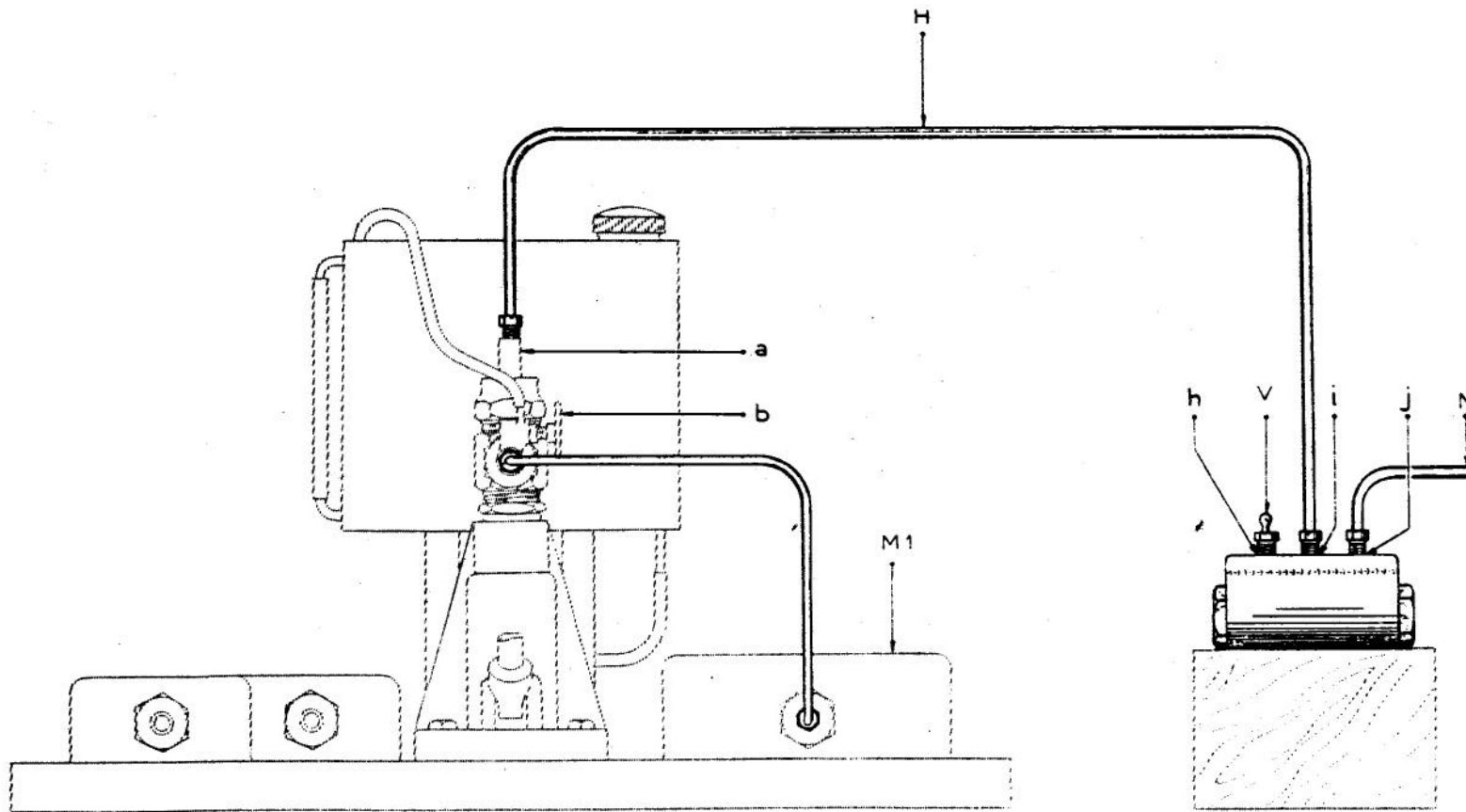

MAIN ACCUMULATOR

PRESSURE TEST

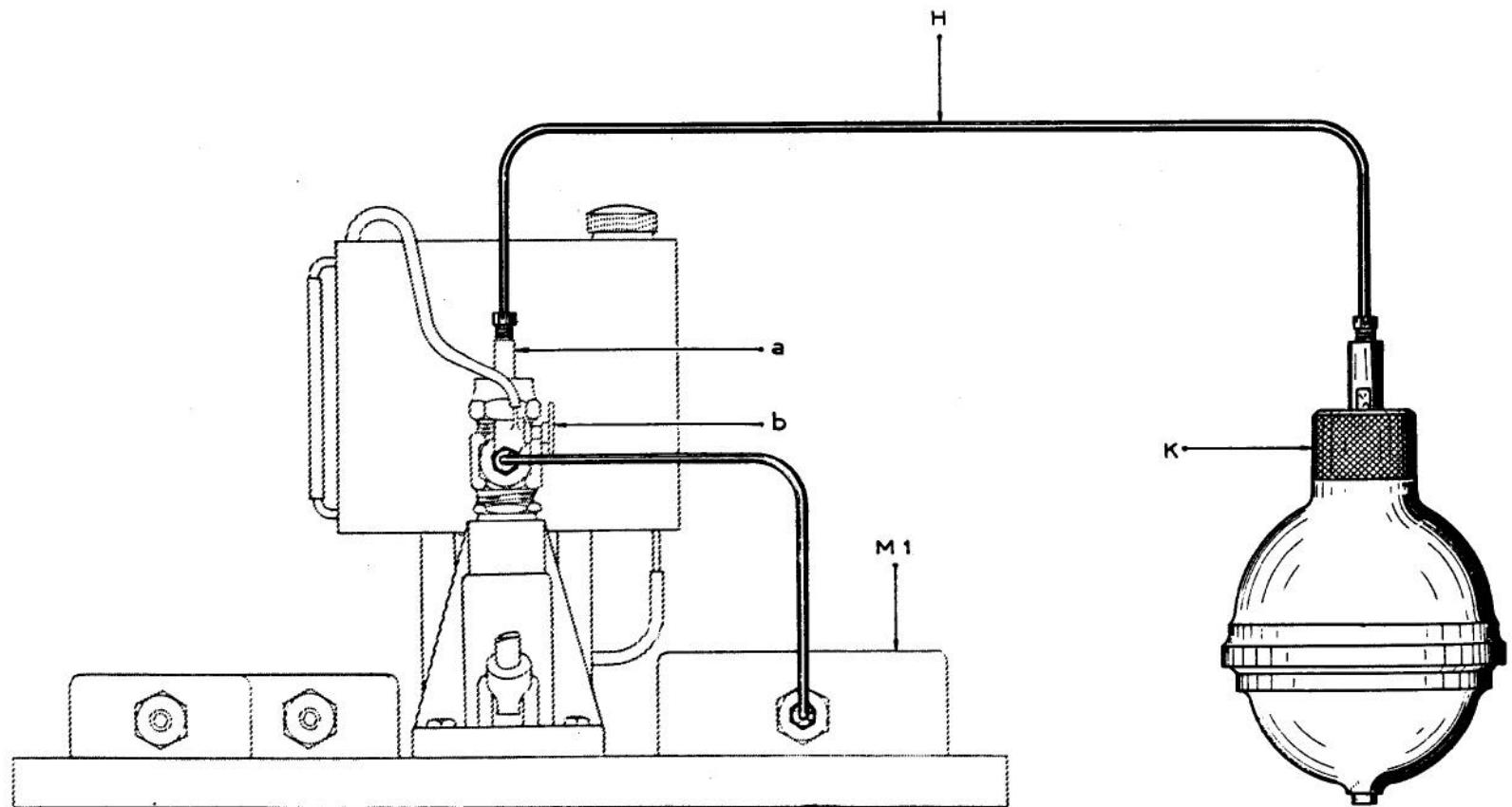

# PRESSURE CONTROL VALVE

INSPECTION OF THE CUT-IN AND CUT-OUT AND FOR LEAKAGE ON THE CAR

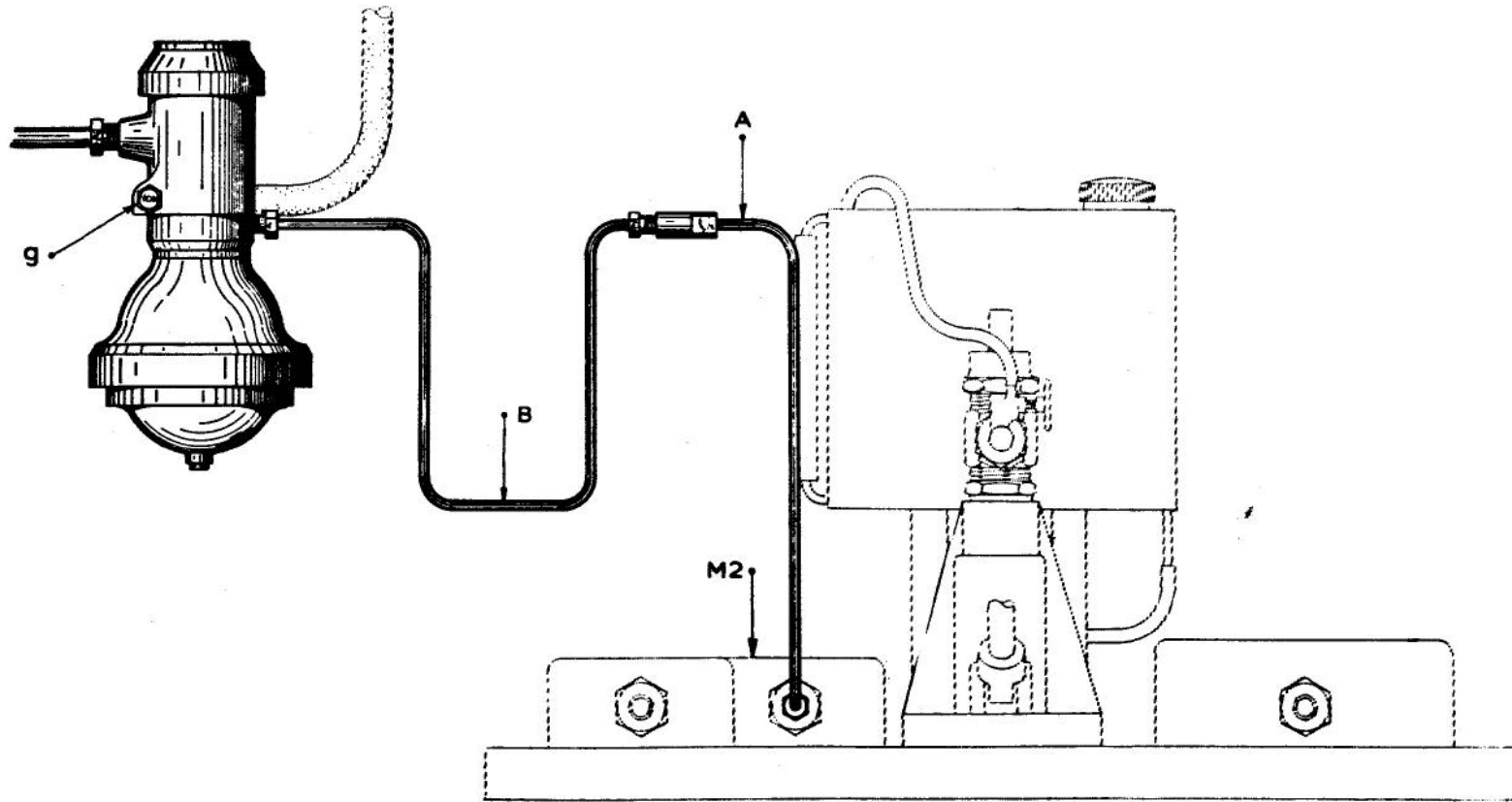

# SUSPENSION CYLINDER

## INSPECTION FOR LEAKAGE

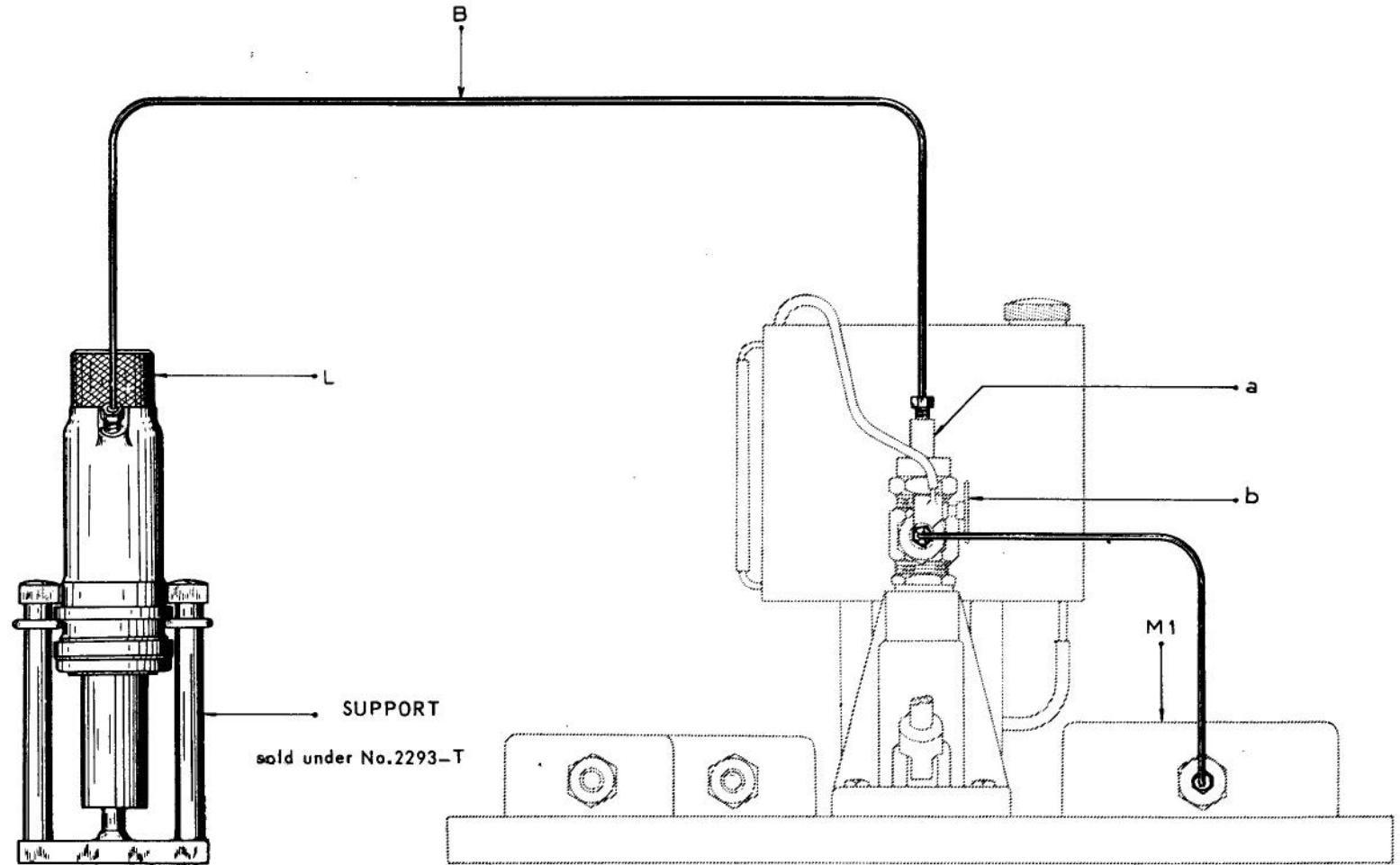

LIFTING FOR TOWING

POINTS OF ANCHORAGE

Fig 1 - LIFTING AT THE FRONT

Fig. 2 - LIFTING AT THE REAR

INSERT AT  $\alpha$  BETWEEN THE CHASSIS AND WOODEN PLANKS A THICKNESS OF SACKING

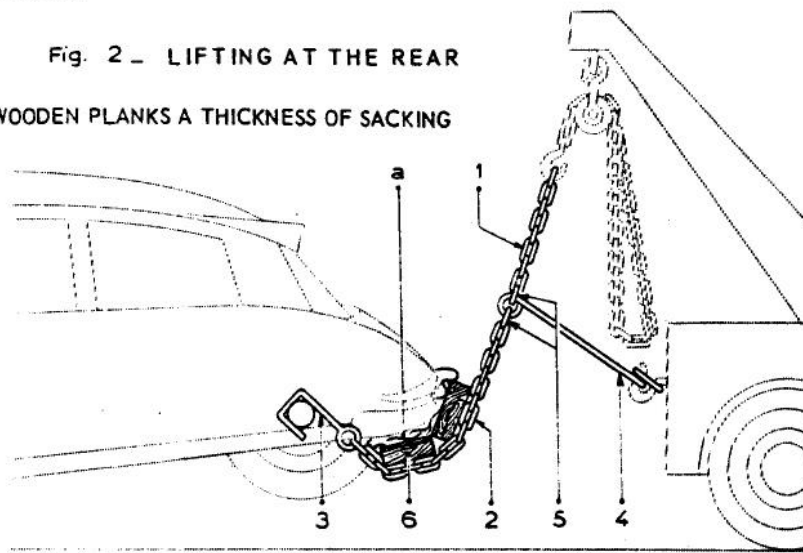
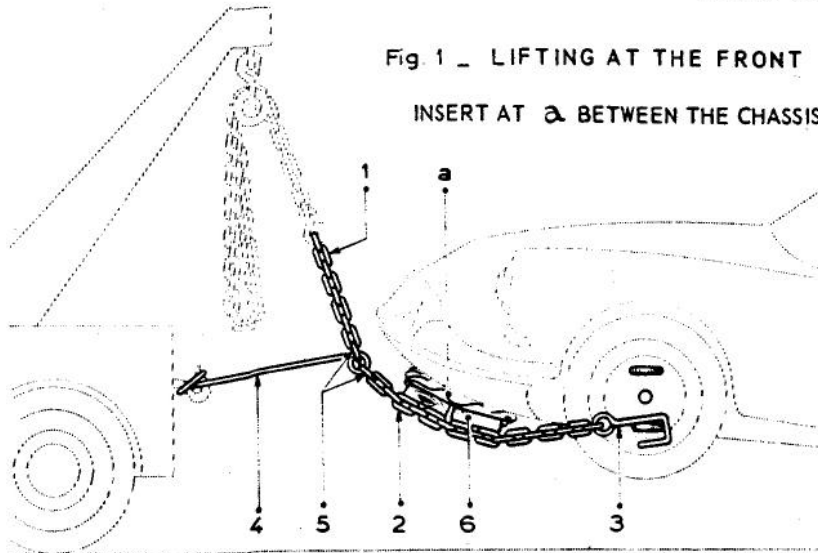

FIT THE HOOKS ON THE LOWER ARMS

FIT THE HOOKS ON THE HUB OF THE ARMS

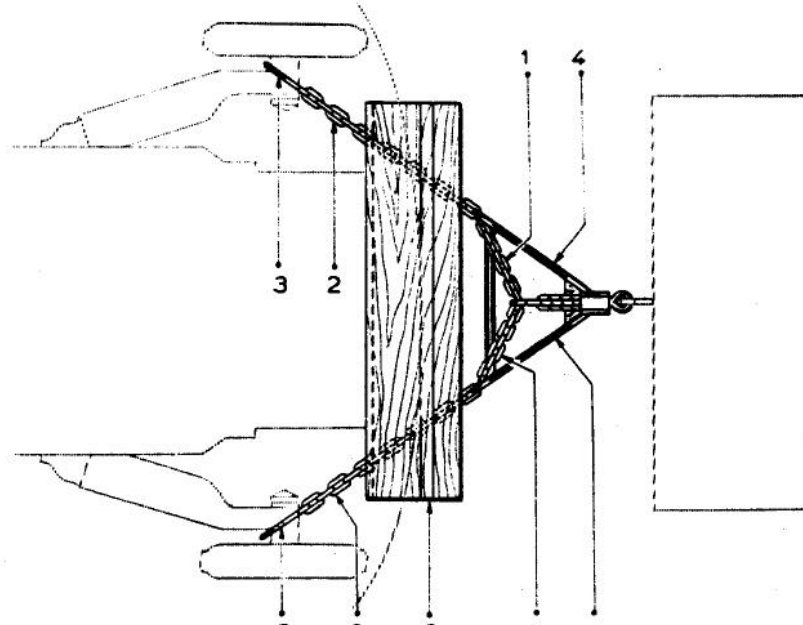
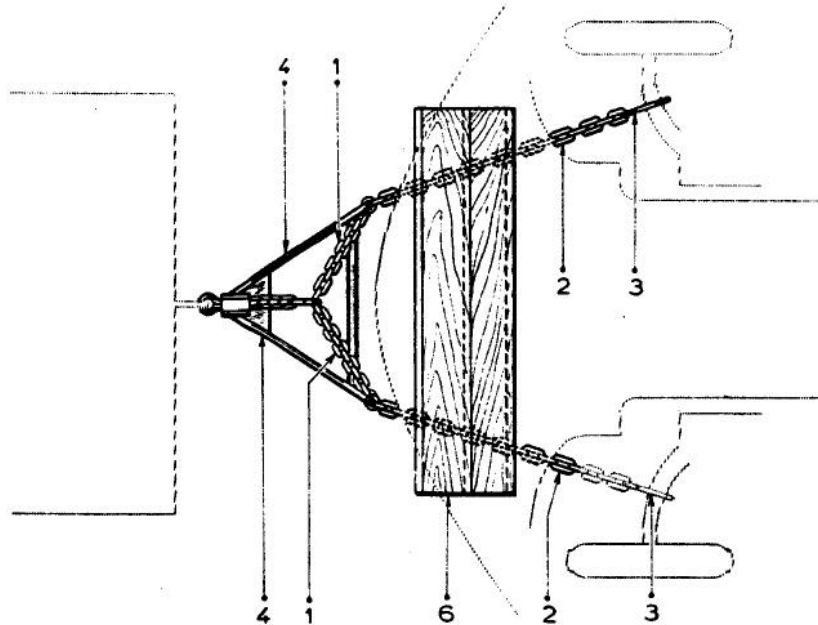

LIFTING THE CAR FOR TOWING

ASSEMBLY OF THE CHAINS

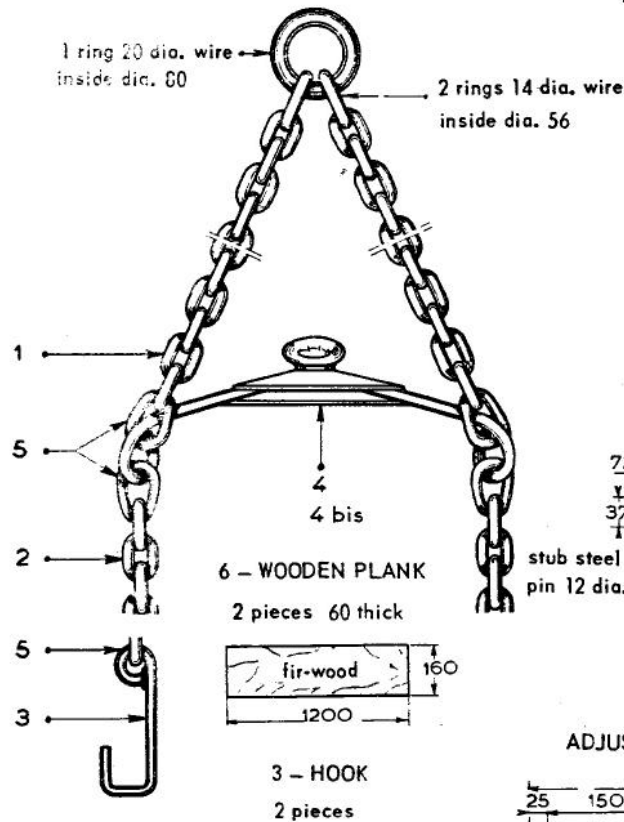

Assemble the rings 5  
before welding

Second quality  
Martin steel.  
UTS 35 to 40 kg/mm<sup>2</sup>  
elongation 28% min.  
under load 275 kg.

Approx. length of chains

4 bis - EXTENSION  
FOR TOWING TRIANGLE

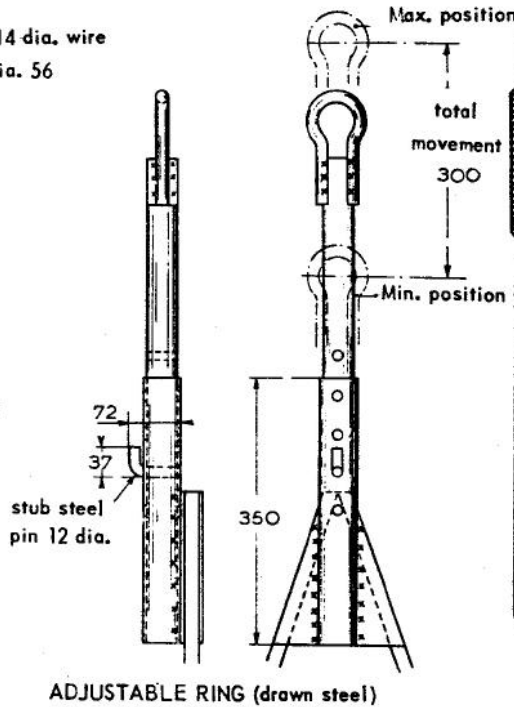

ADJUSTABLE RING (drawn steel)

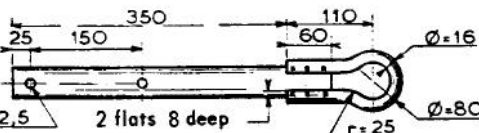

EXTENSION TUBE

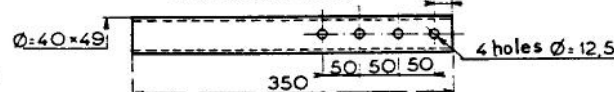

- chain 1 = 792 mm between connecting links 12 CNM 601 22 links
- chain 2 = 900 mm between connecting links 12 CNM 601 25 links

4 - TOWING TRIANGLE  
Second quality Martin steel

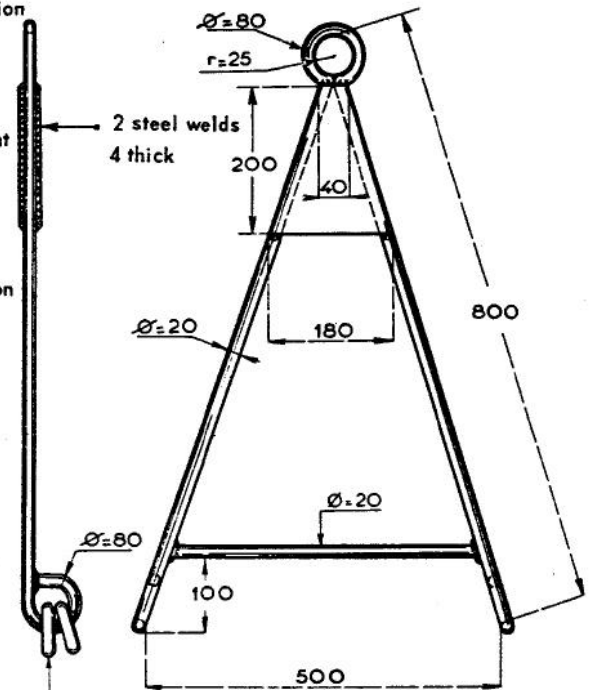

Assemble the rings 5  
before welding

5 - CONNECTING LINK

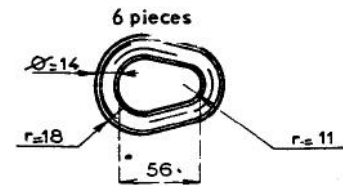

Second quality  
Martin steel.  
UTS 35 to 40 kg/mm<sup>2</sup>  
elongation 28% min.  
under load 275 kg.



SUPPORT FOR TOWING

ASSEMBLY

- |   |  |  |
|---|--|--|
| A | 1 Cold drawn weldless steel tube<br>37 x 32 or 33 x 42 | Drawn tube, right hand                       |
| B | 1 Cold drawn weldless steel tube<br>37 x 42 or 33 x 42 | Drawn tube, left hand                        |
| C | 1 3mm sheet steel                                      | Rear distance piece for draw tubes.          |
| D | 1 8mm sheet steel                                      | Fixing plate for ball joint.                 |
| E | 2 3mm sheet steel                                      | Andle plate securing rear distance piece.    |
| F | 1 3mm sheet steel                                      | Plate securing rear distance piece           |
| G | 1 Cold drawn weldless steel tube<br>30 x 39            | Transverse rear tubes                        |
| H | 1 4mm sheet steel                                      | Lockplate securing front of right hand tube. |
| J | 1 Steel thickness as required                          | Packing piece.                               |

Total permissible weight to be towed - 1650 lbs.

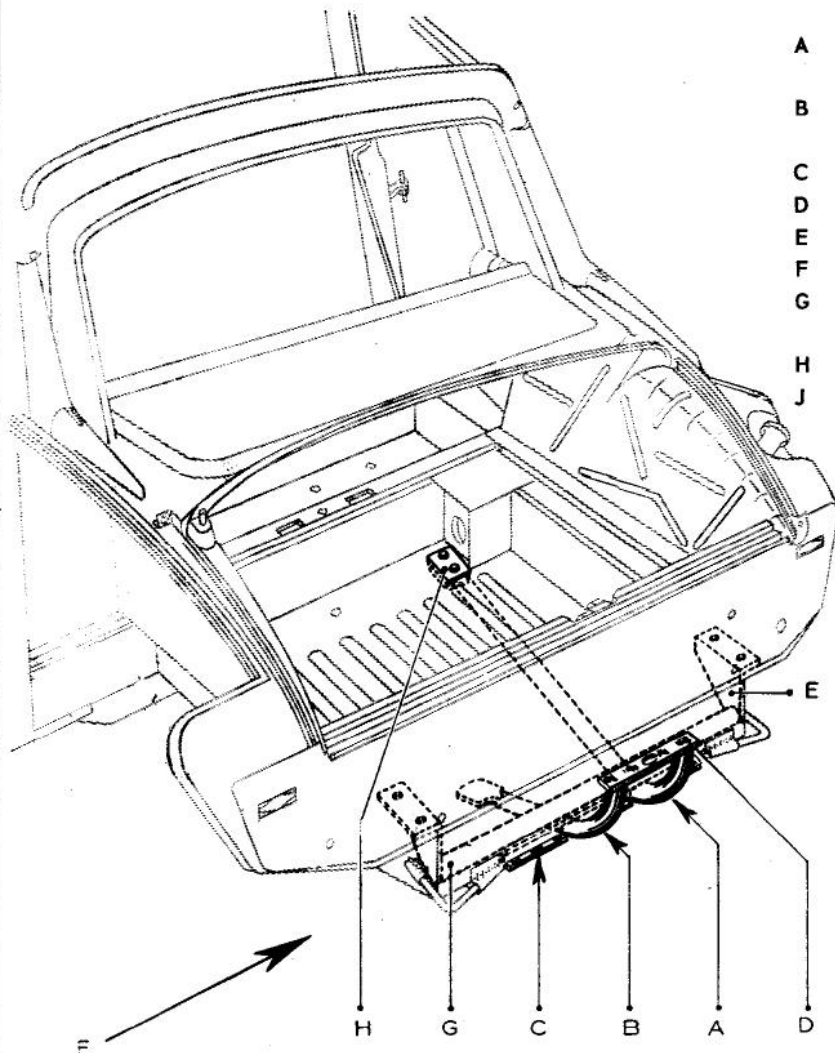

VIEW IN DIRECTION F

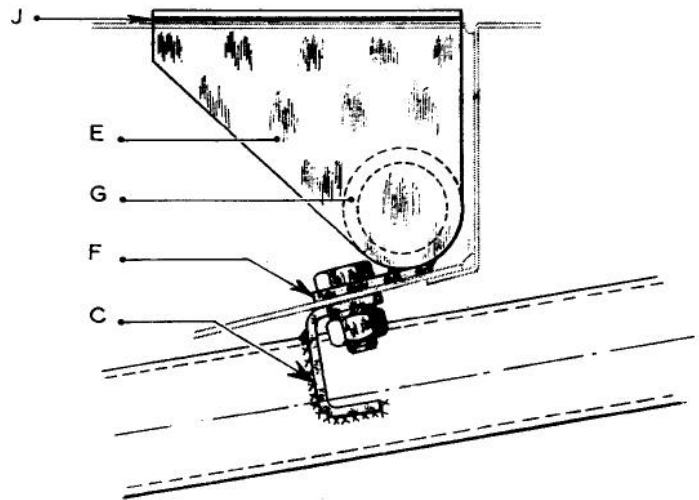

SUPPORT FOR TOWING

DETAILS

ASSEMBLY 2

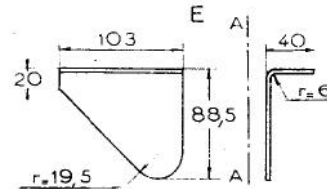
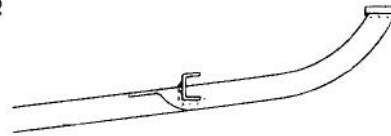

right hand part symmetrical in relation to centreline A

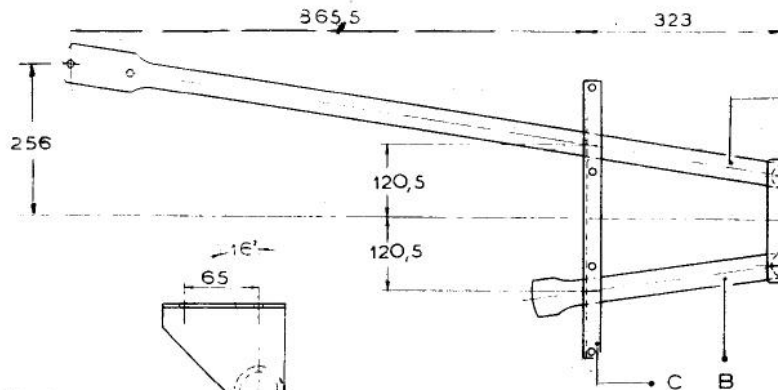

VIEW IN DIRECTION F

2 (dimensions of welding)  
26

ASSEMBLY 3

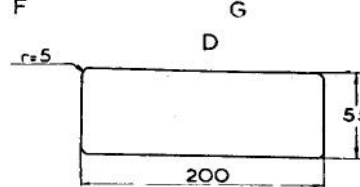
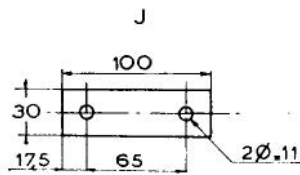
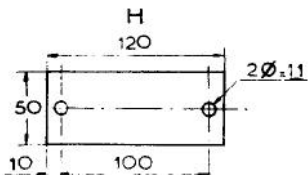
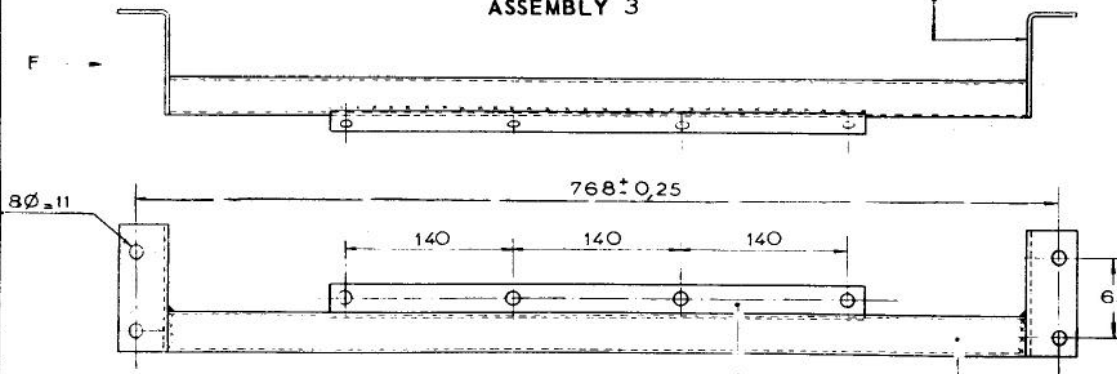

SECTION X

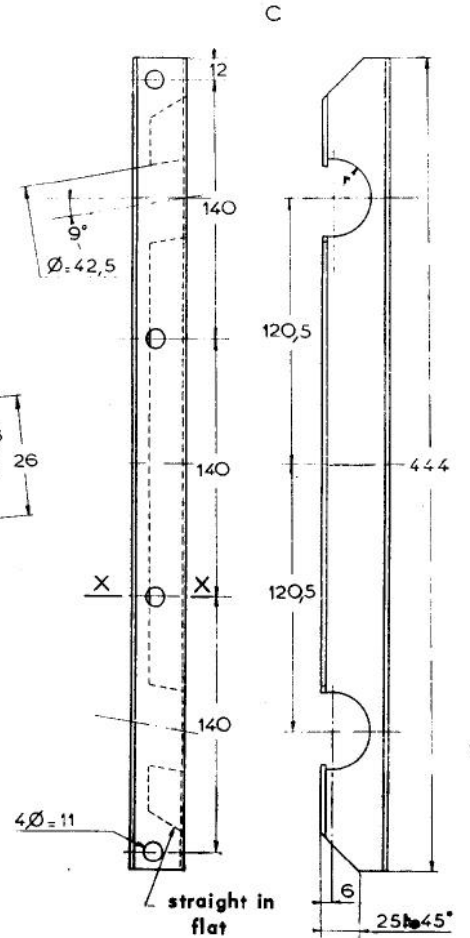
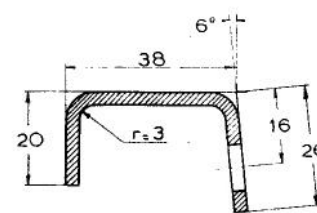

straight in flat

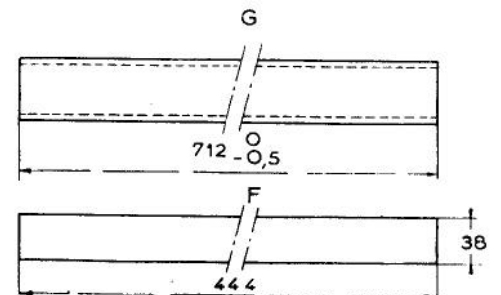

SUPPORT FOR TOWING

139

DETAILS

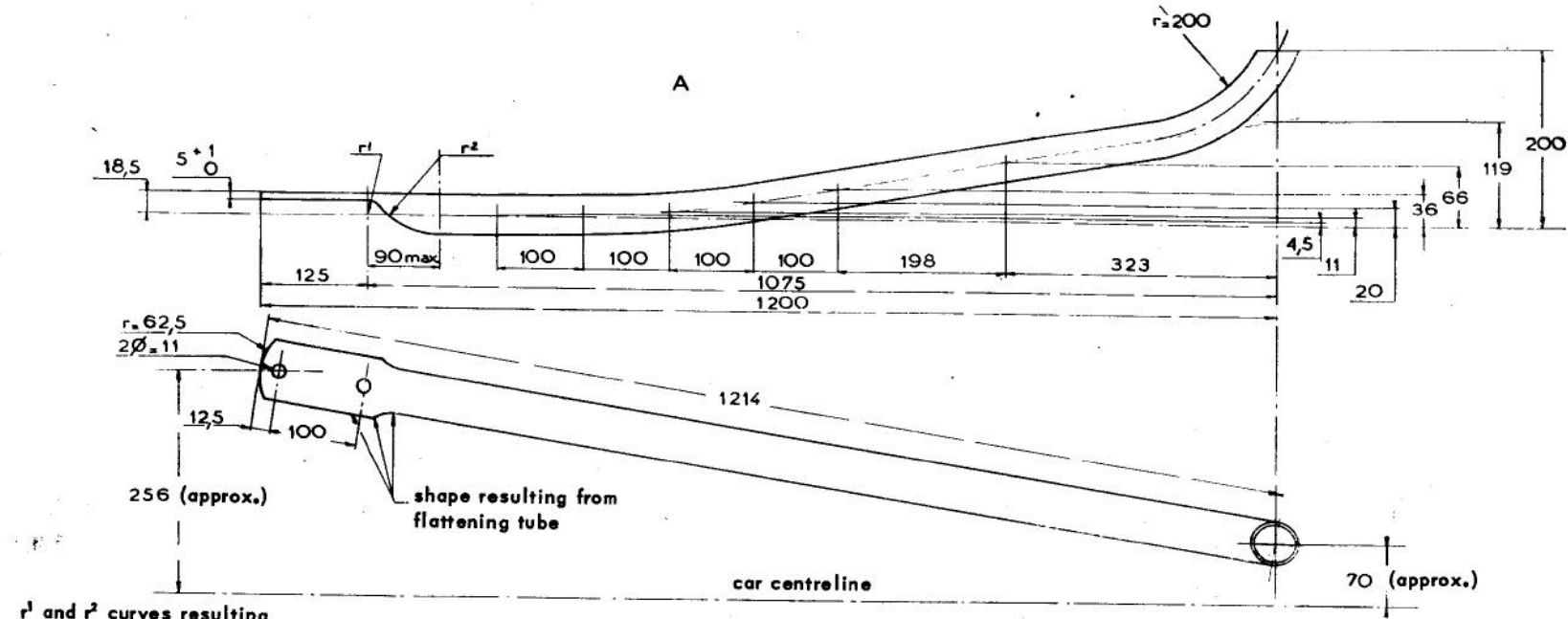

$r^1$  and  $r^2$  curves resulting from flattening tube

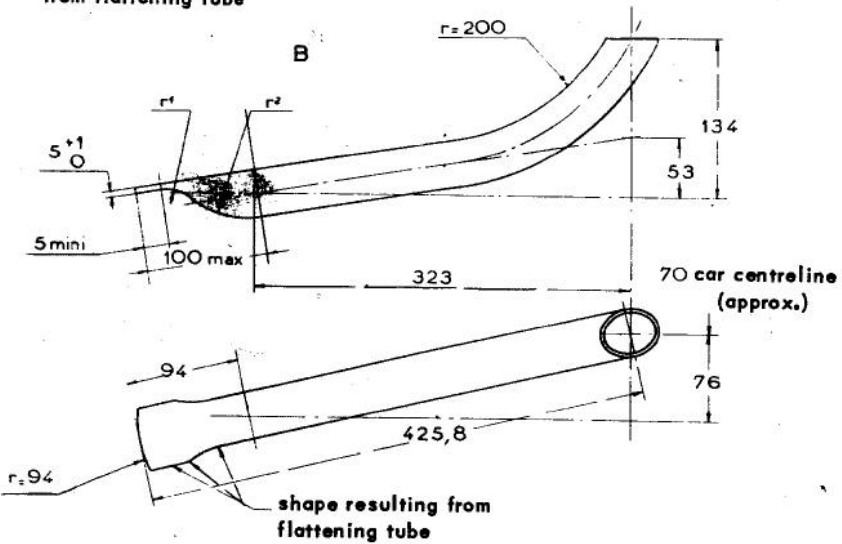

MODIFICATION TO REAR BASE OF REAR UNIT

