

10^{CV} CITROËN

TYPE C⁴ F

CATALOGUE
DES
PIÈCES DÉTACHÉES
(ILLUSTRATIONS)



SOCIÉTÉ ANONYME ANDRÉ CITROËN

Capital : 400.000.000 Francs

143, Quai de Javel - PARIS (XV^e)

SERVICE DES PIÈCES DÉTACHÉES

175, Rue du Président-Wilson
LEVALLOIS-PERRET (Seine)

R. C. Seine 216.018 B



MOTEUR

CYLINDRE-CARTER

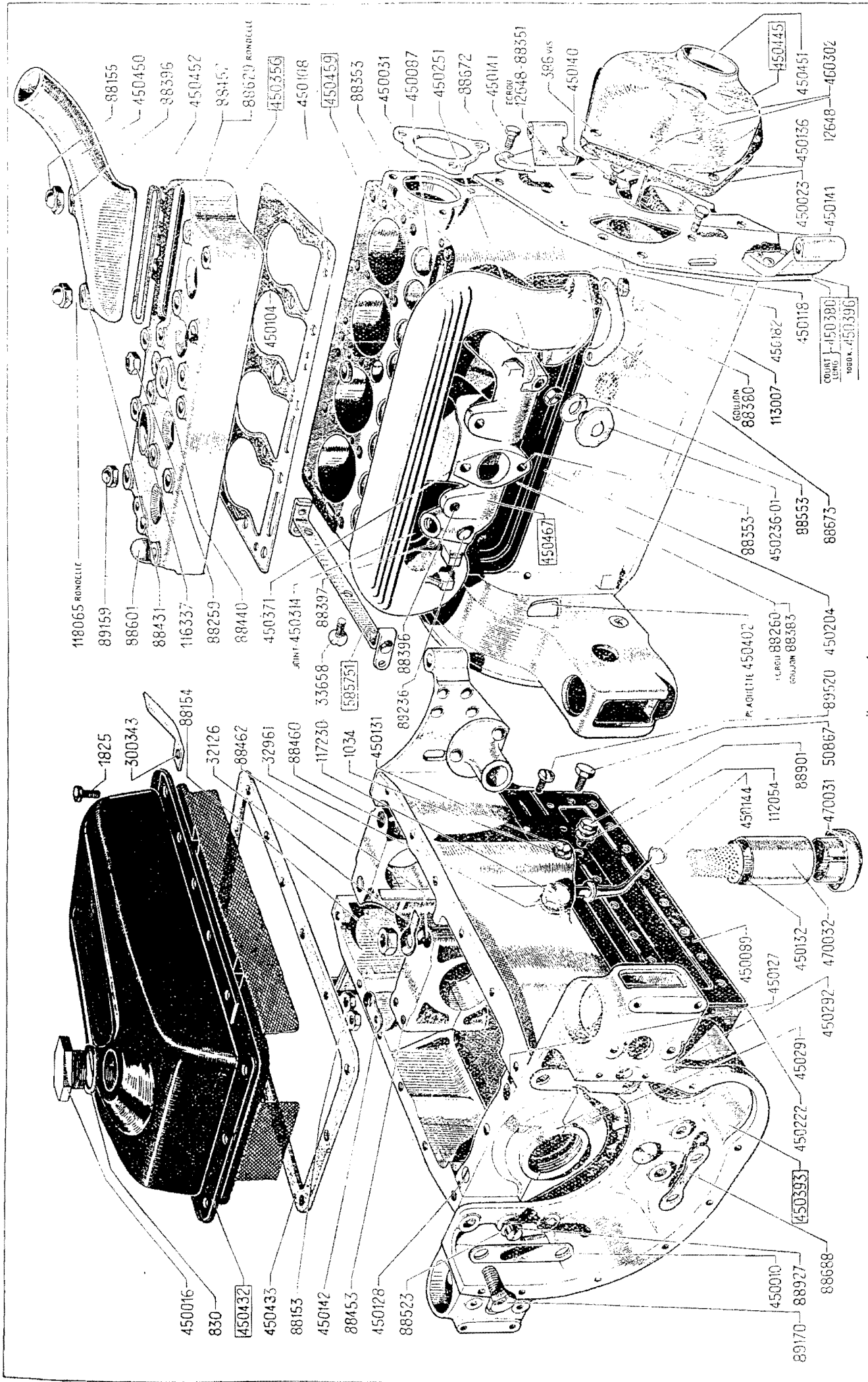



MOTEUR

VILEBREQUIN BIELLES - PISTONS

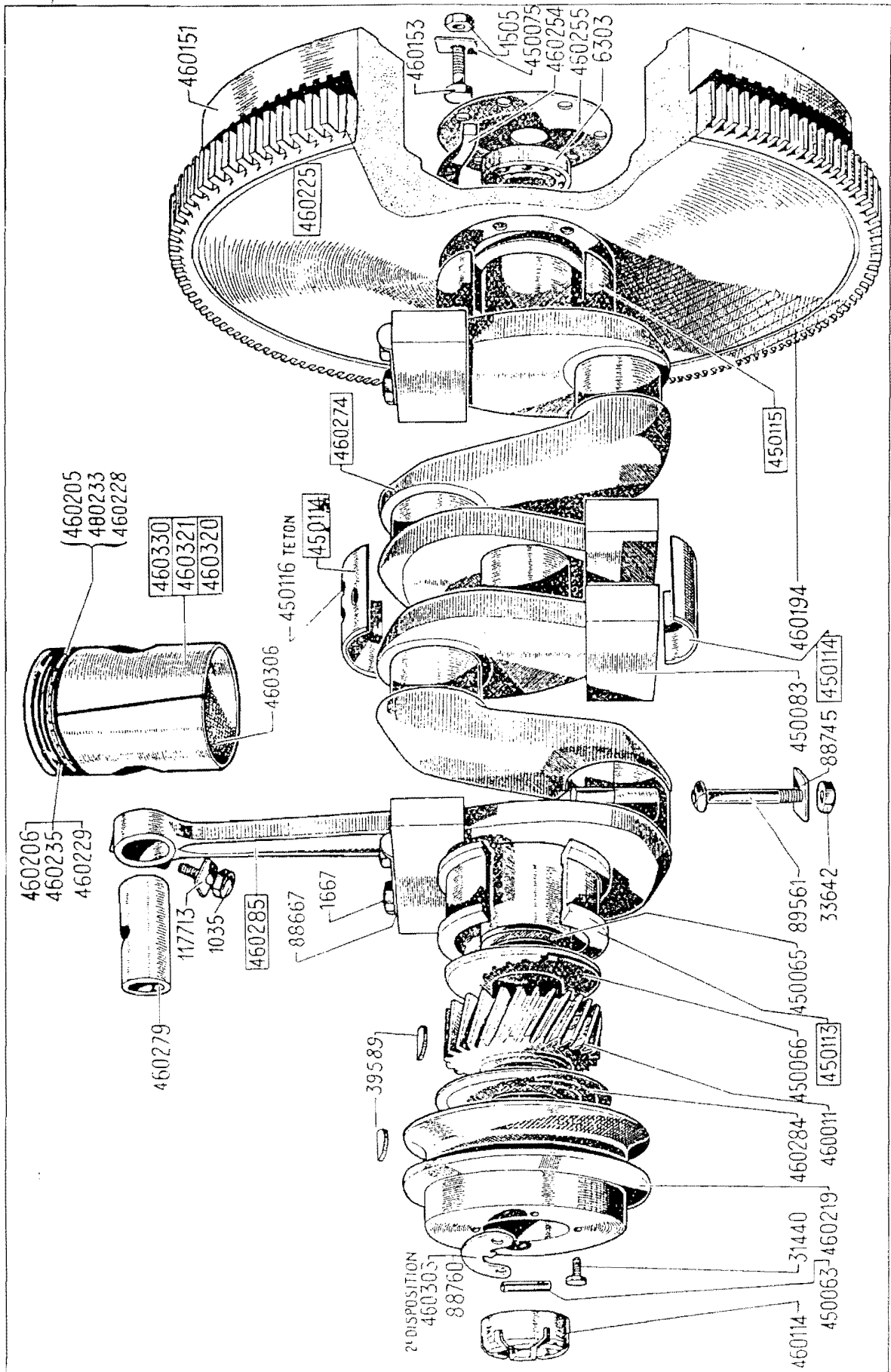

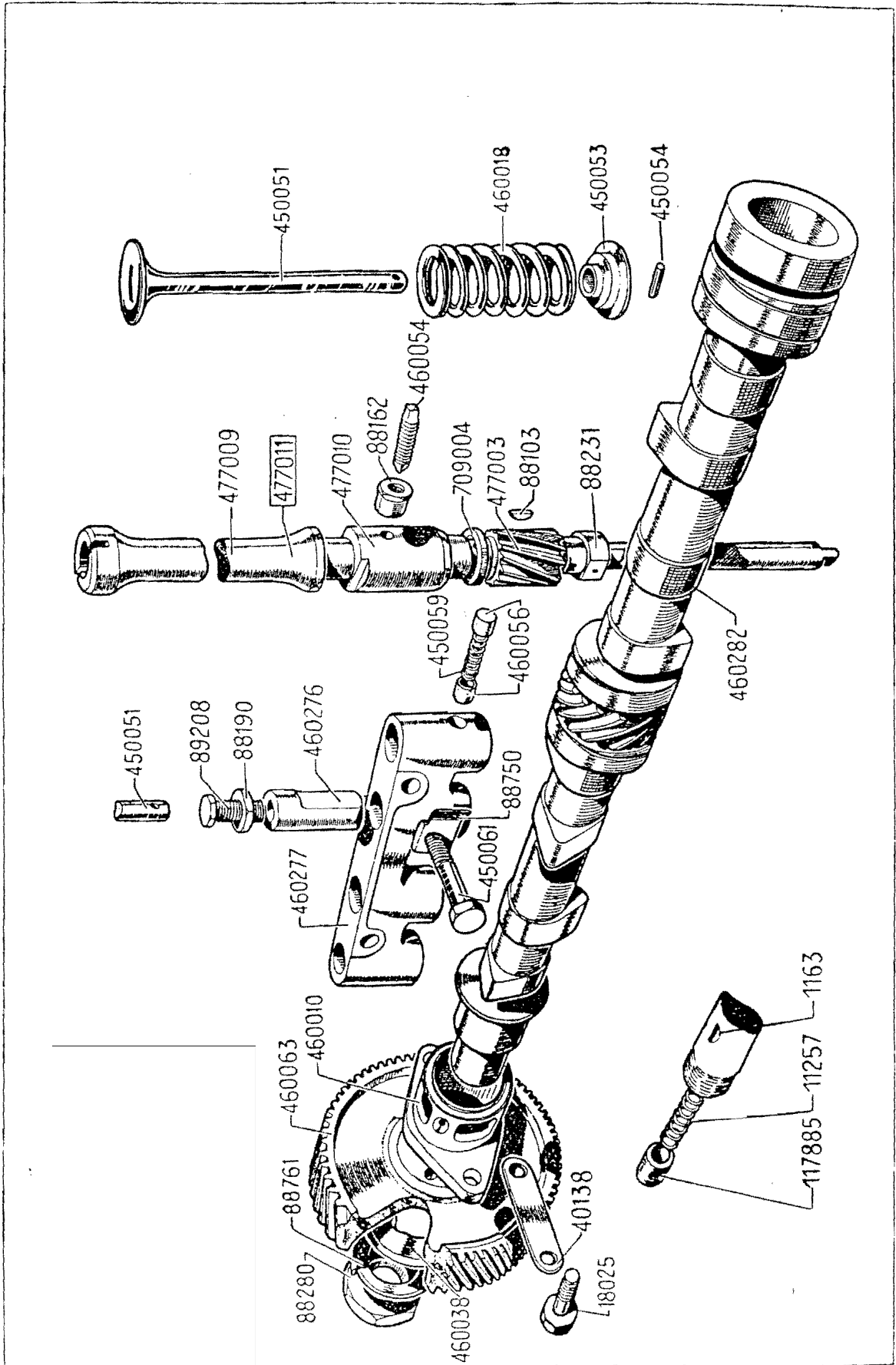



MOTEUR

POMPE A HUILE CIRCULATION D'HUILE

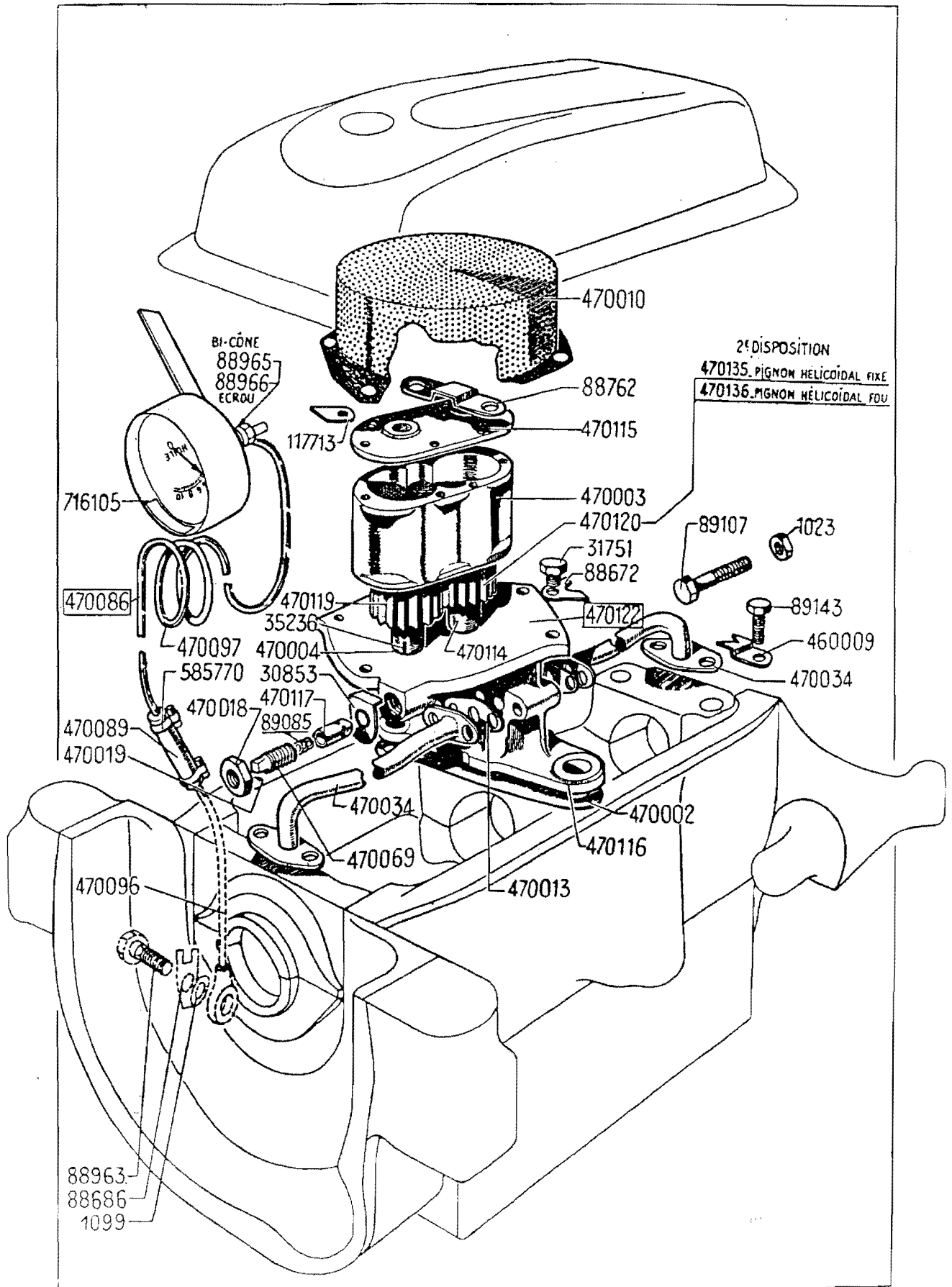



MOTEUR

VENTILATEUR POMPE A EAU

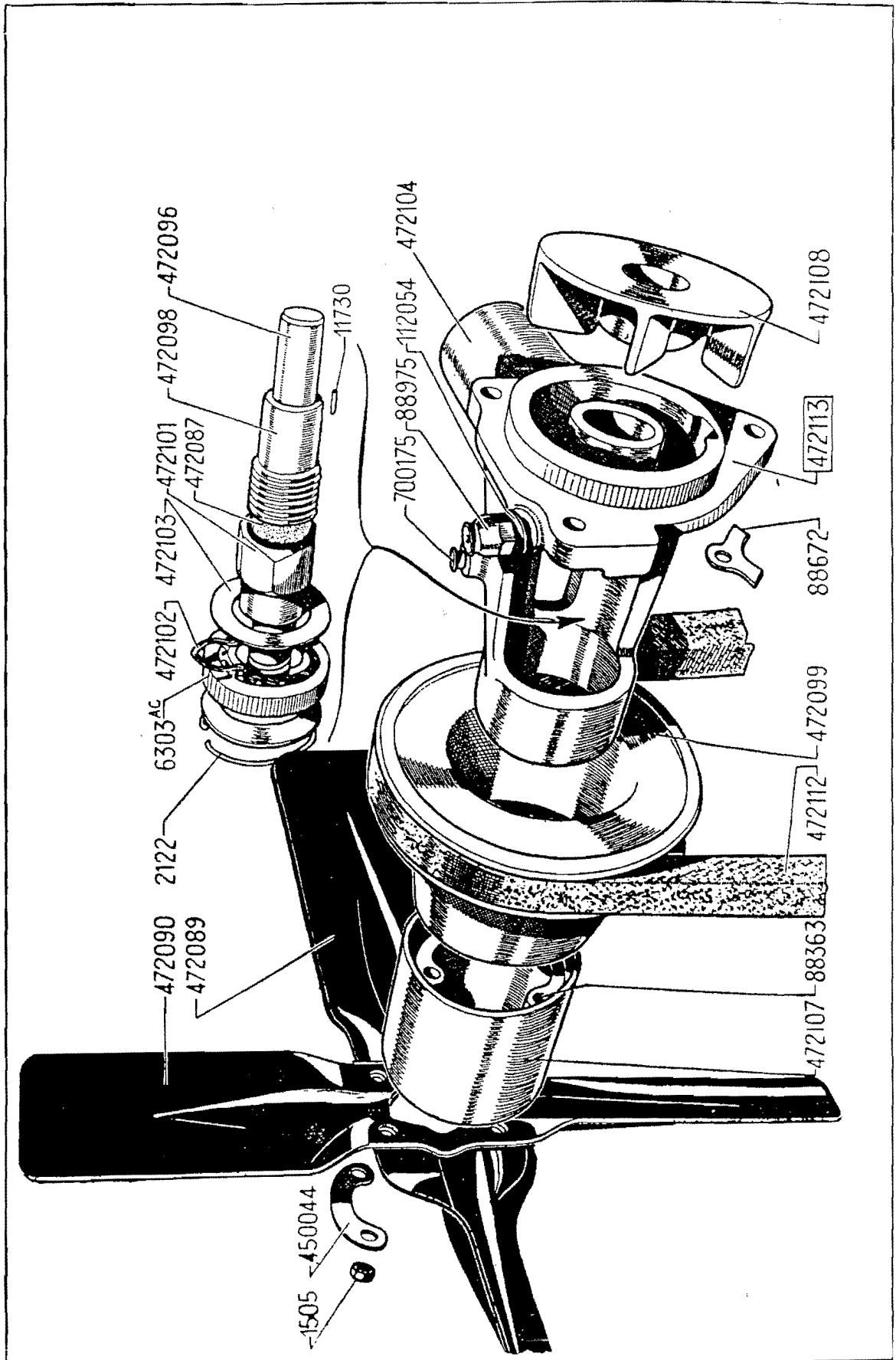



MOTEUR

COMMANDE D'ACCÉLÉRATEUR

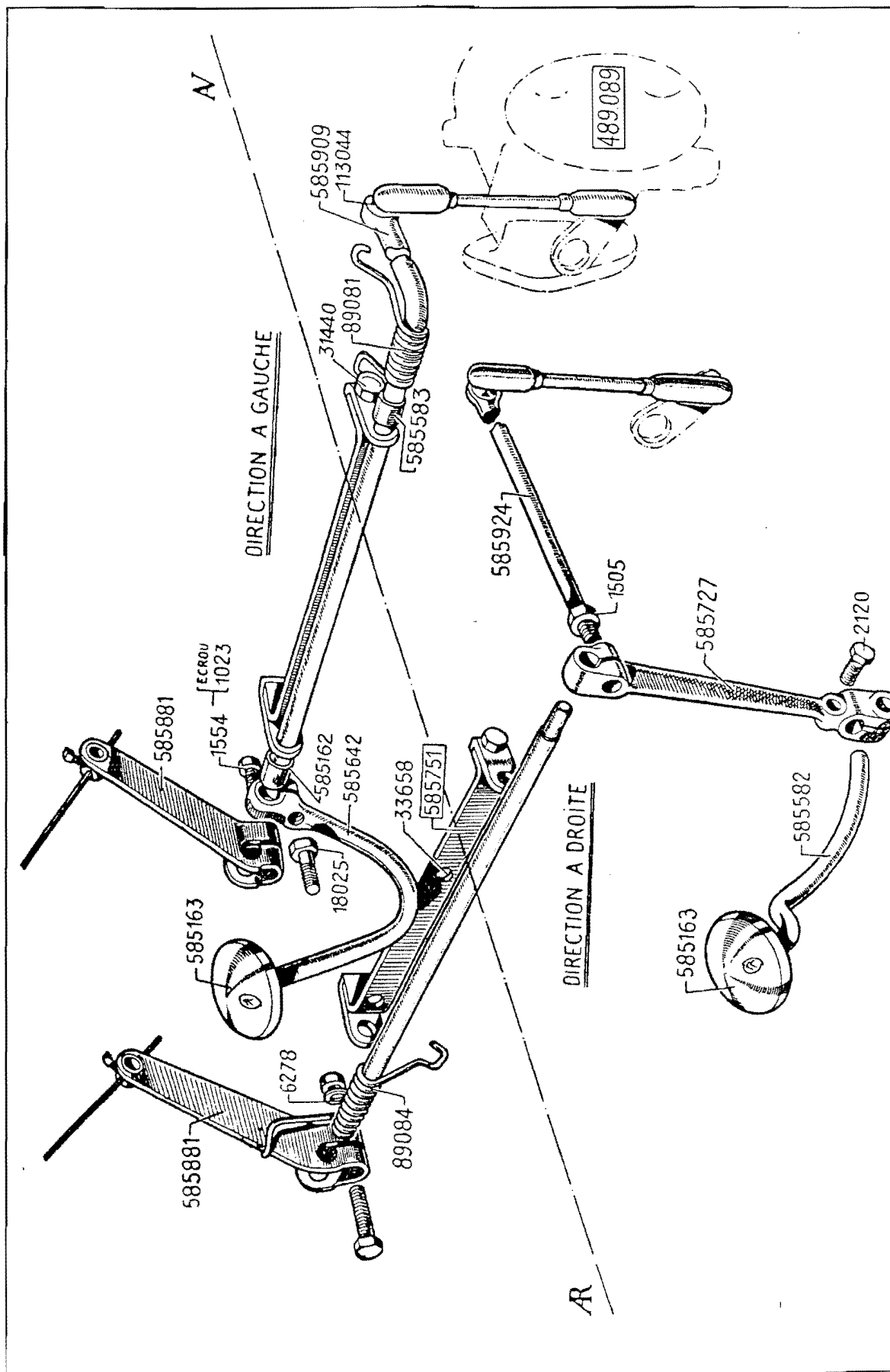



EMBRAYAGE

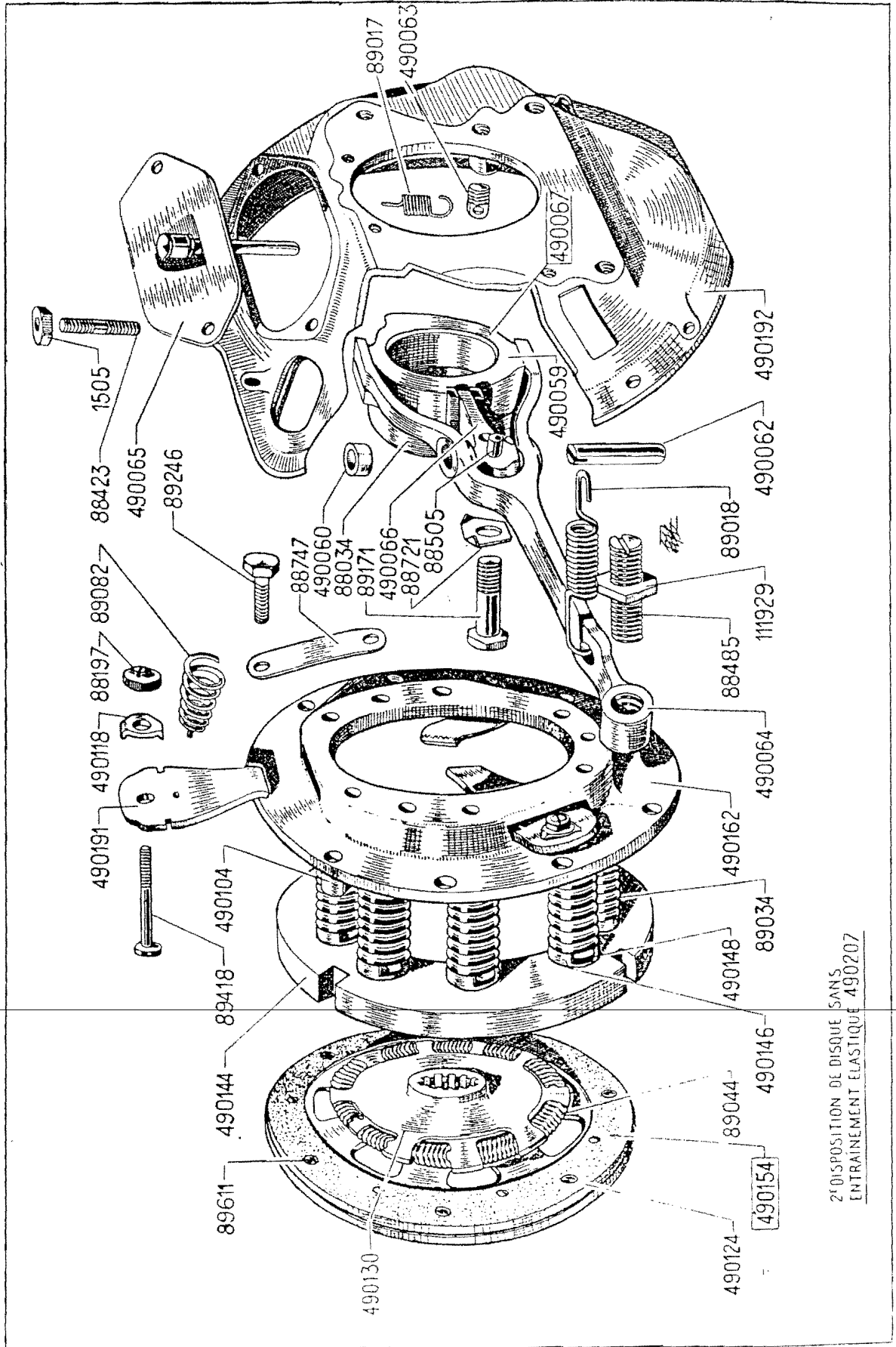

2^e DISPOSITION DE DISQUE SANS
ENTRAÎNEMENT ELASTIQUE 490207



BOITE DE VITESSES

CARTER - COUVERCLE DE CHANGEMENT DE VITESSES

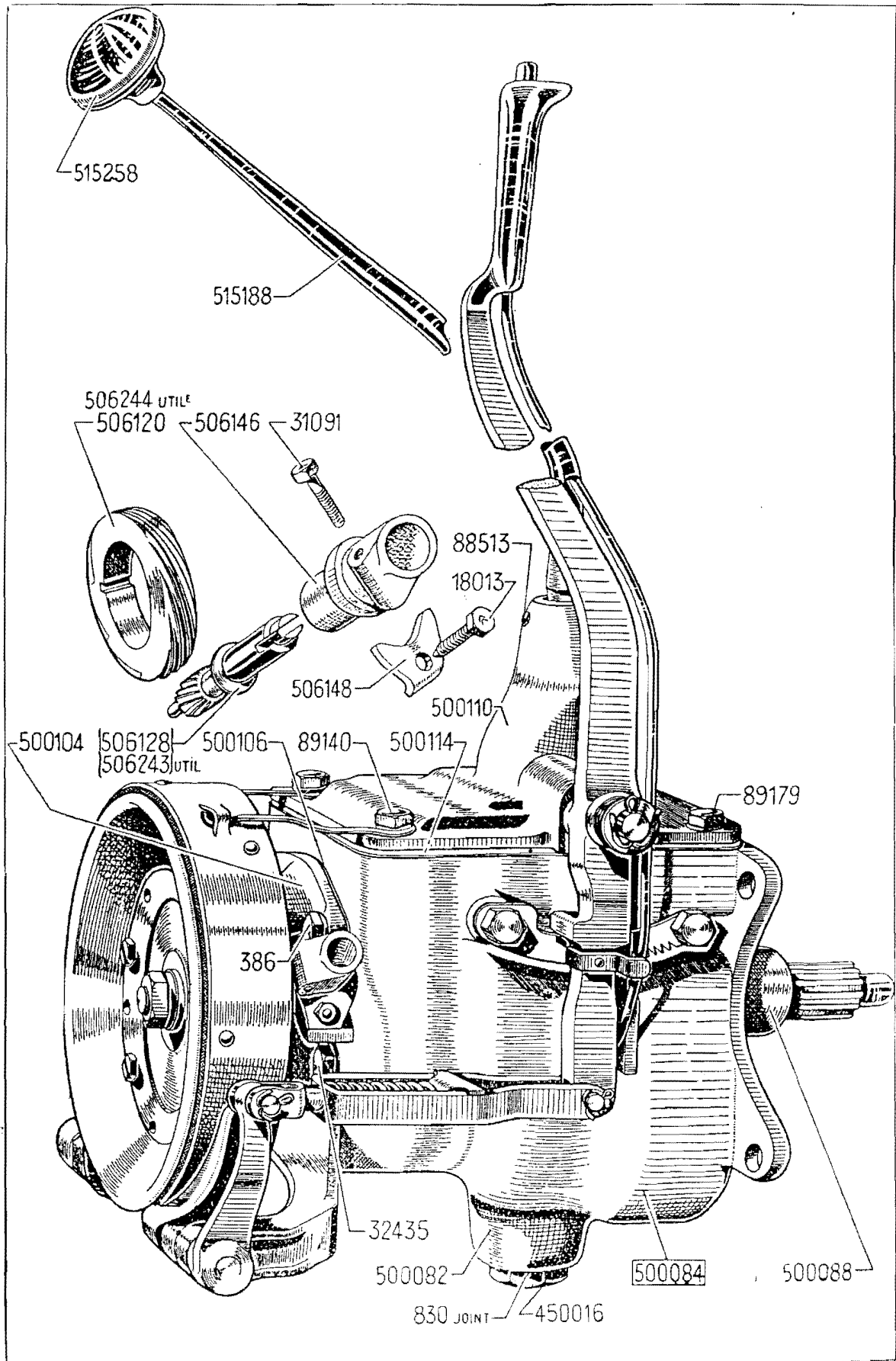



BOITE DE VITESSES

PIGNON - CARTER GRILLE DE VÉROUILLAGE

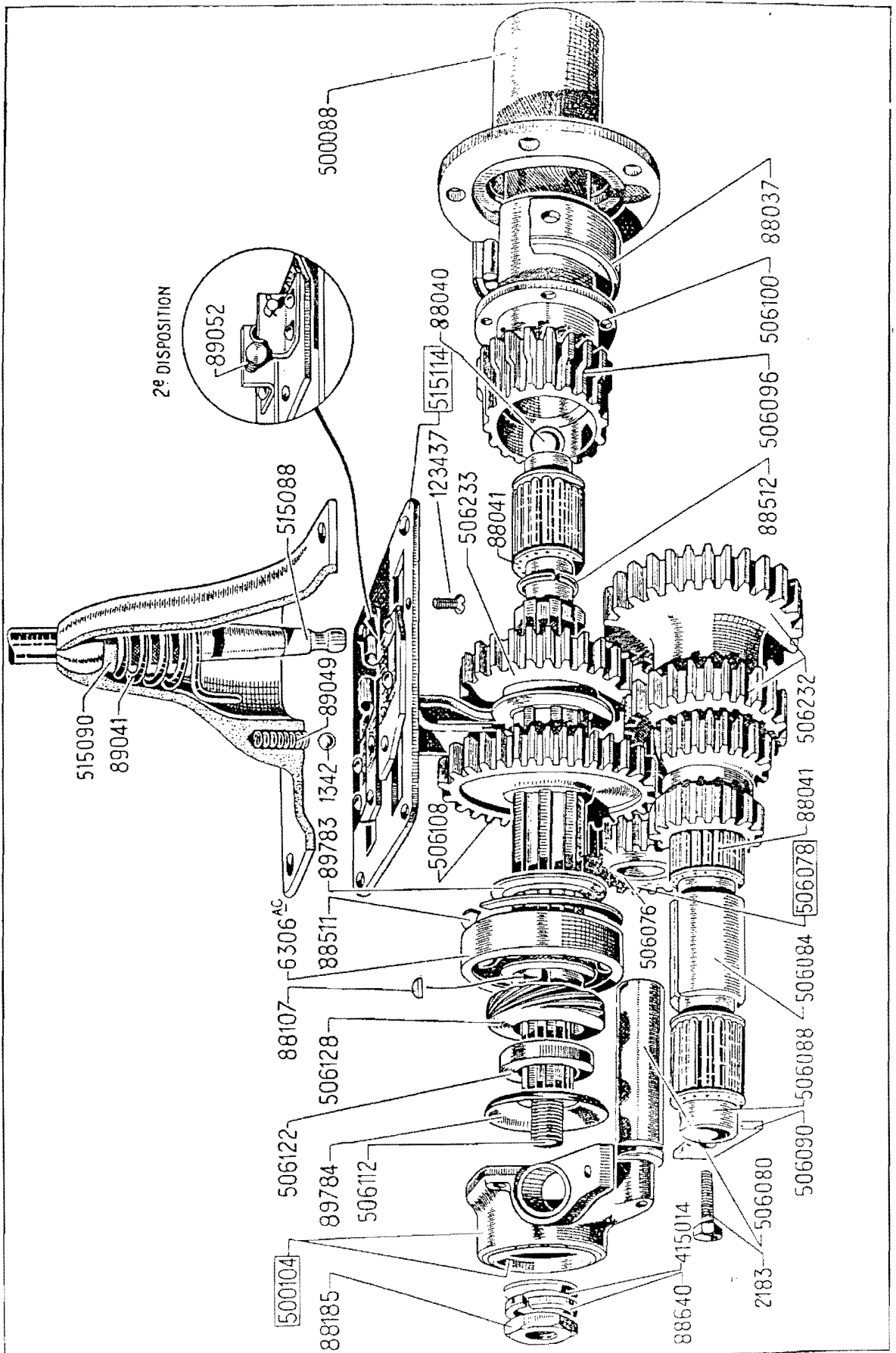



BOITE DE VITESSES

LEVIER DE FREIN SUR TRANSMISSION

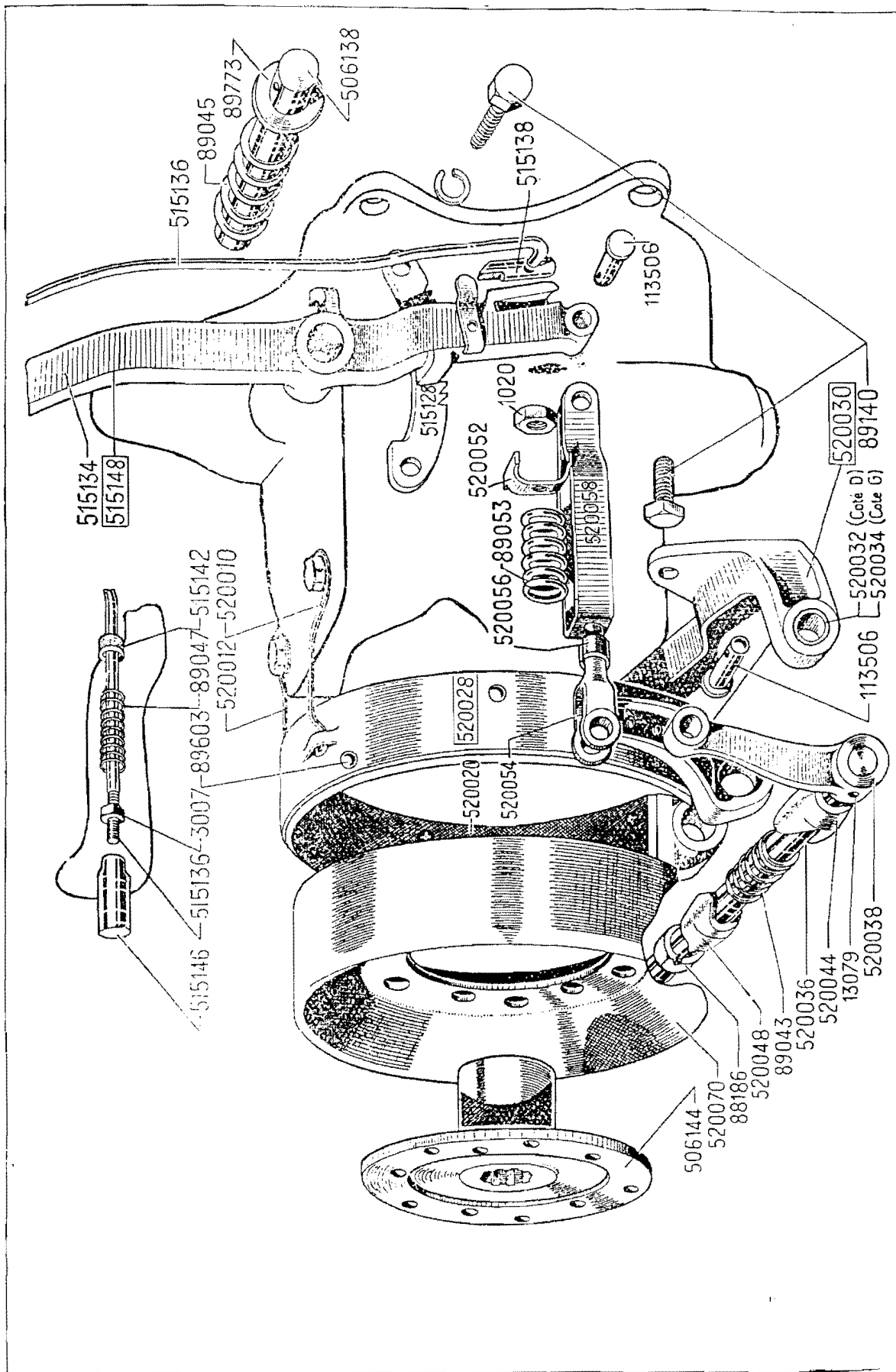



ARBRE DE TRANSMISSION

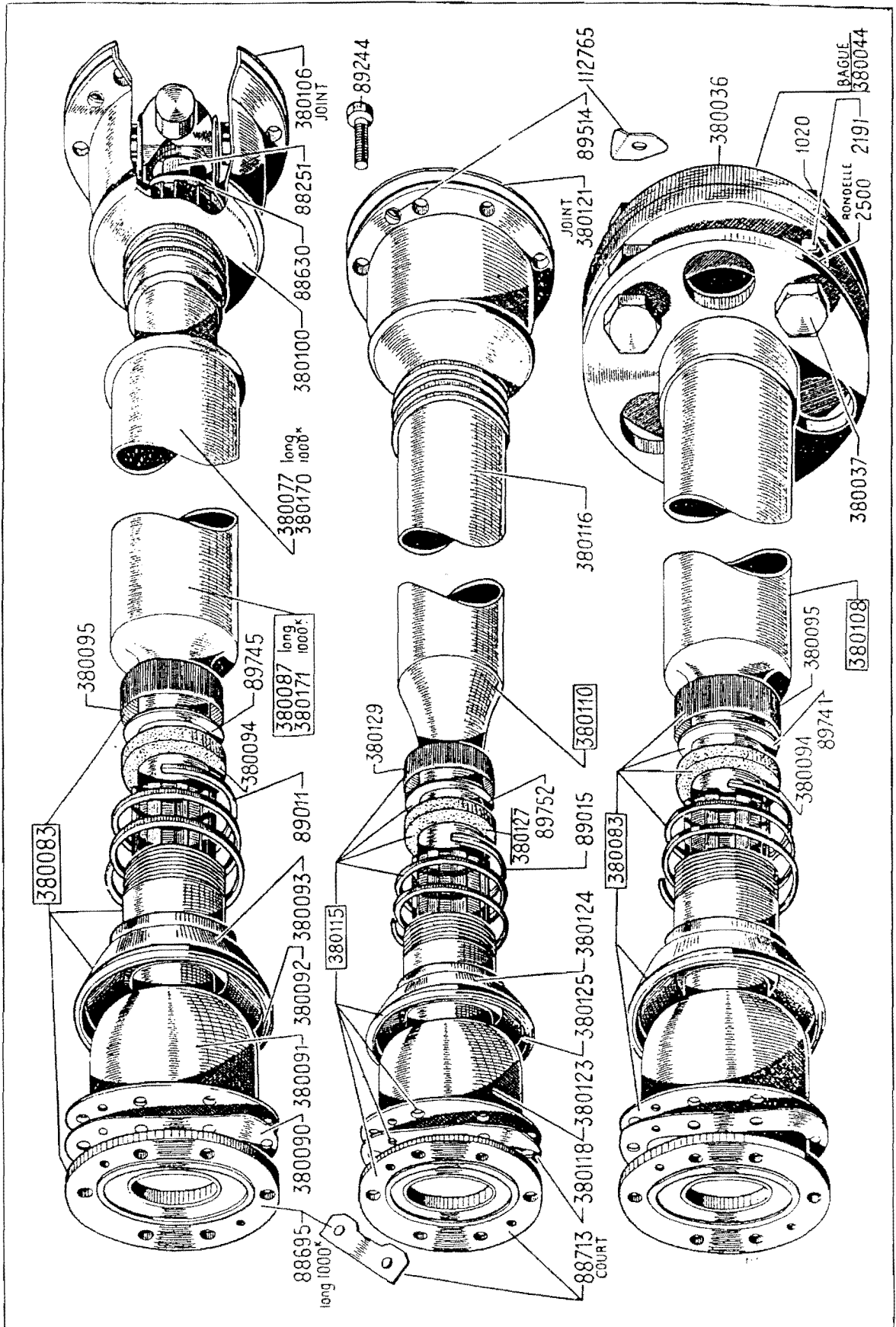

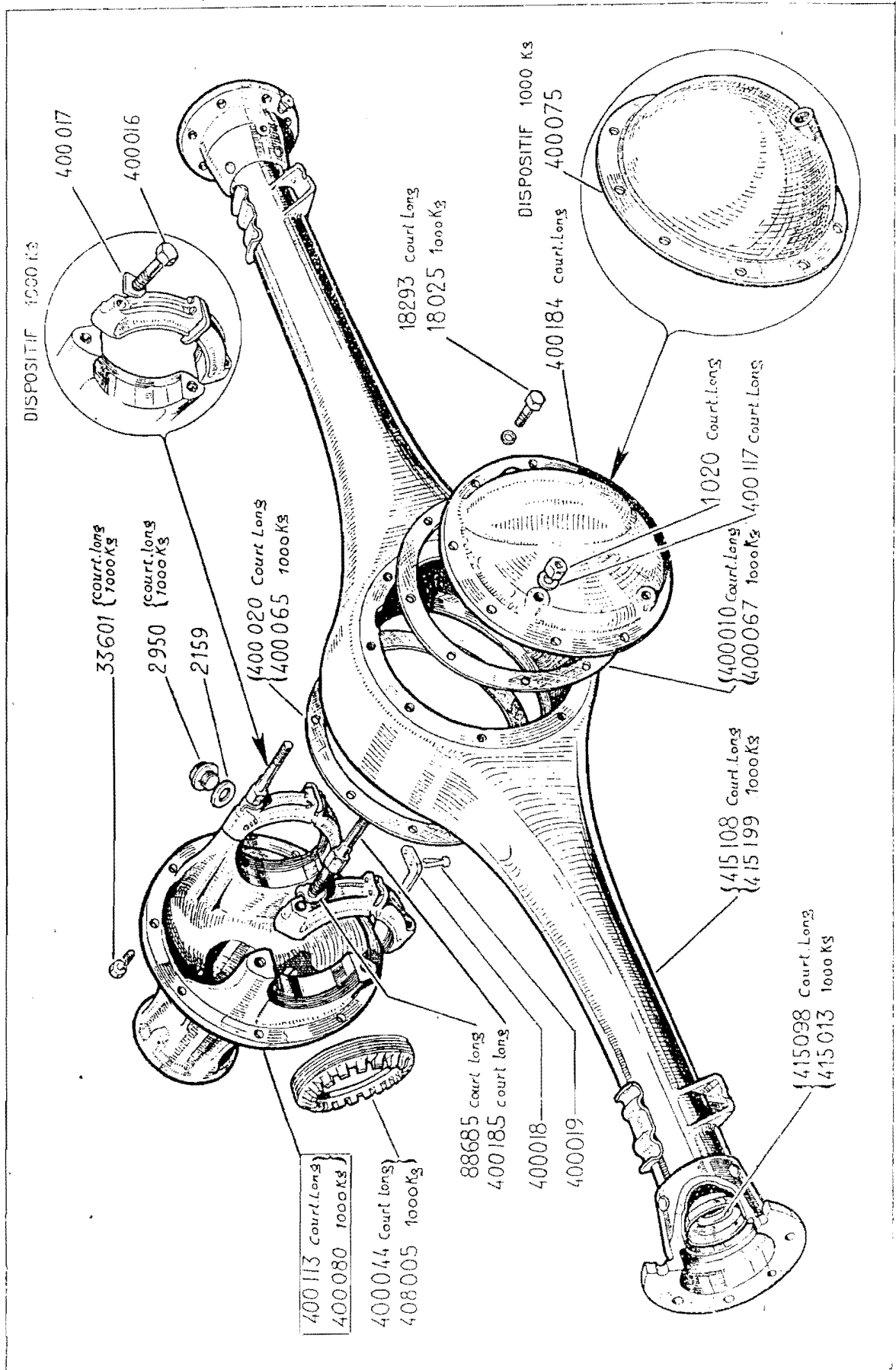

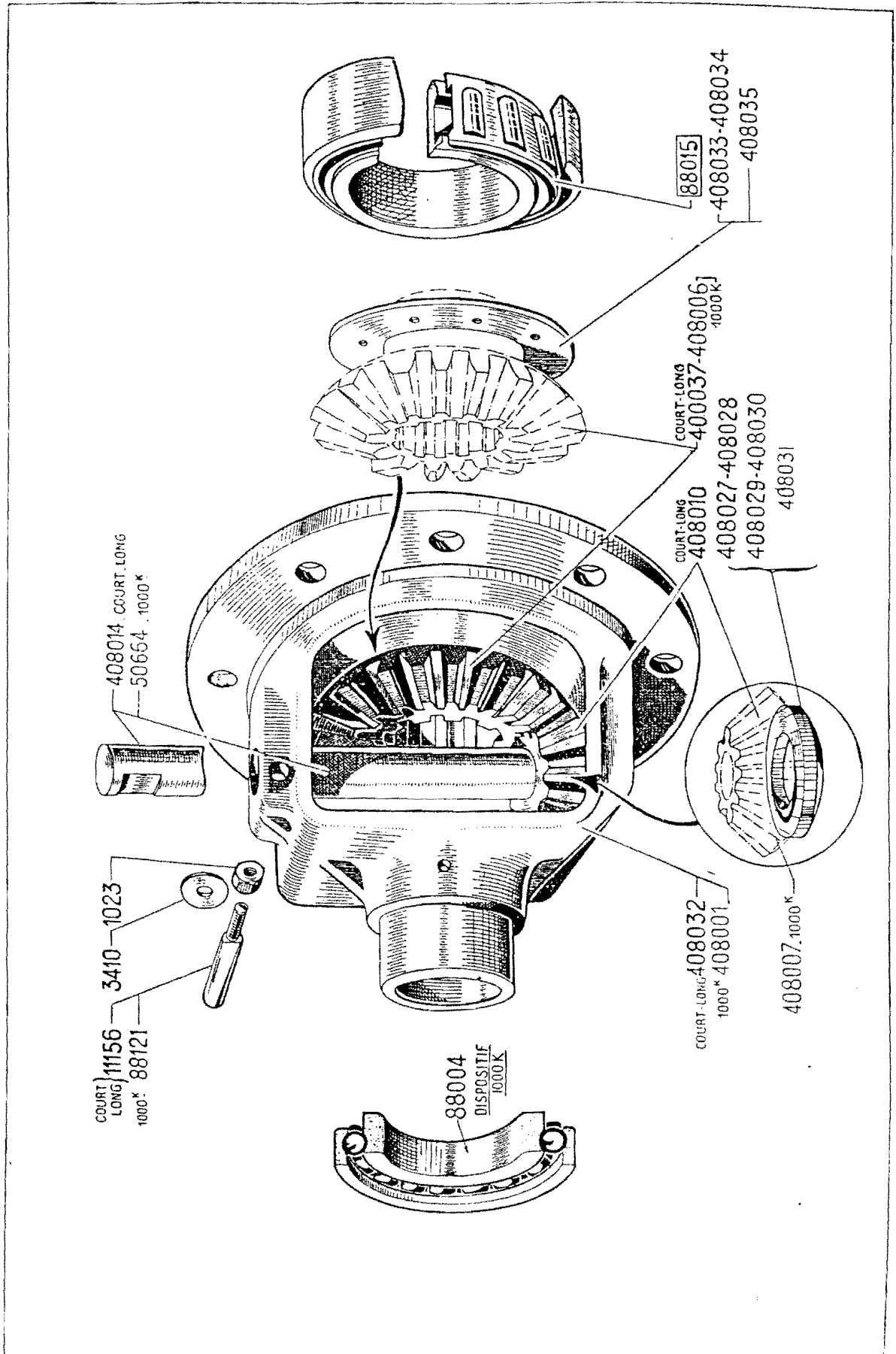

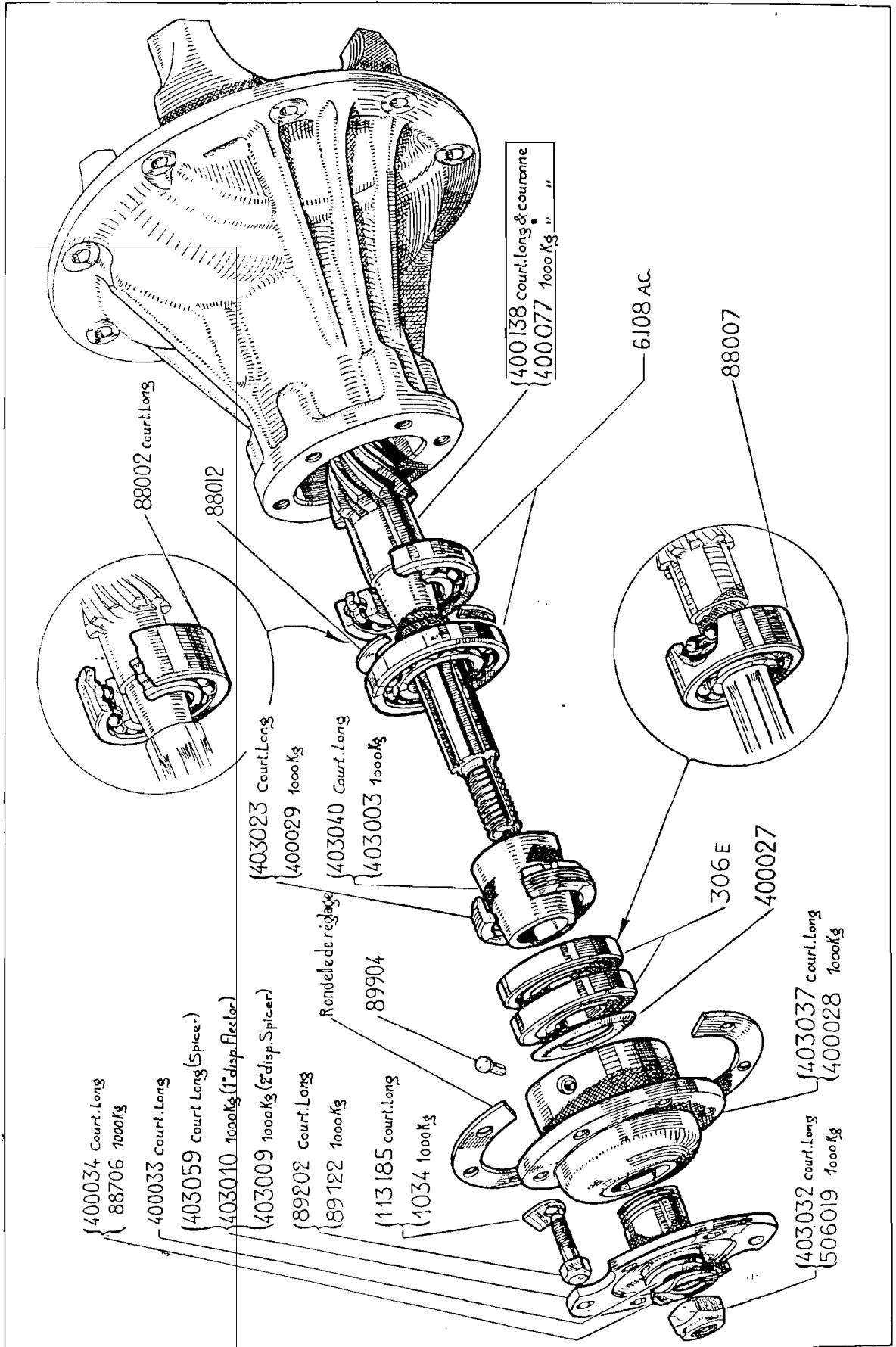



PONT AR

ARBRES DE PONT - MOYEUX

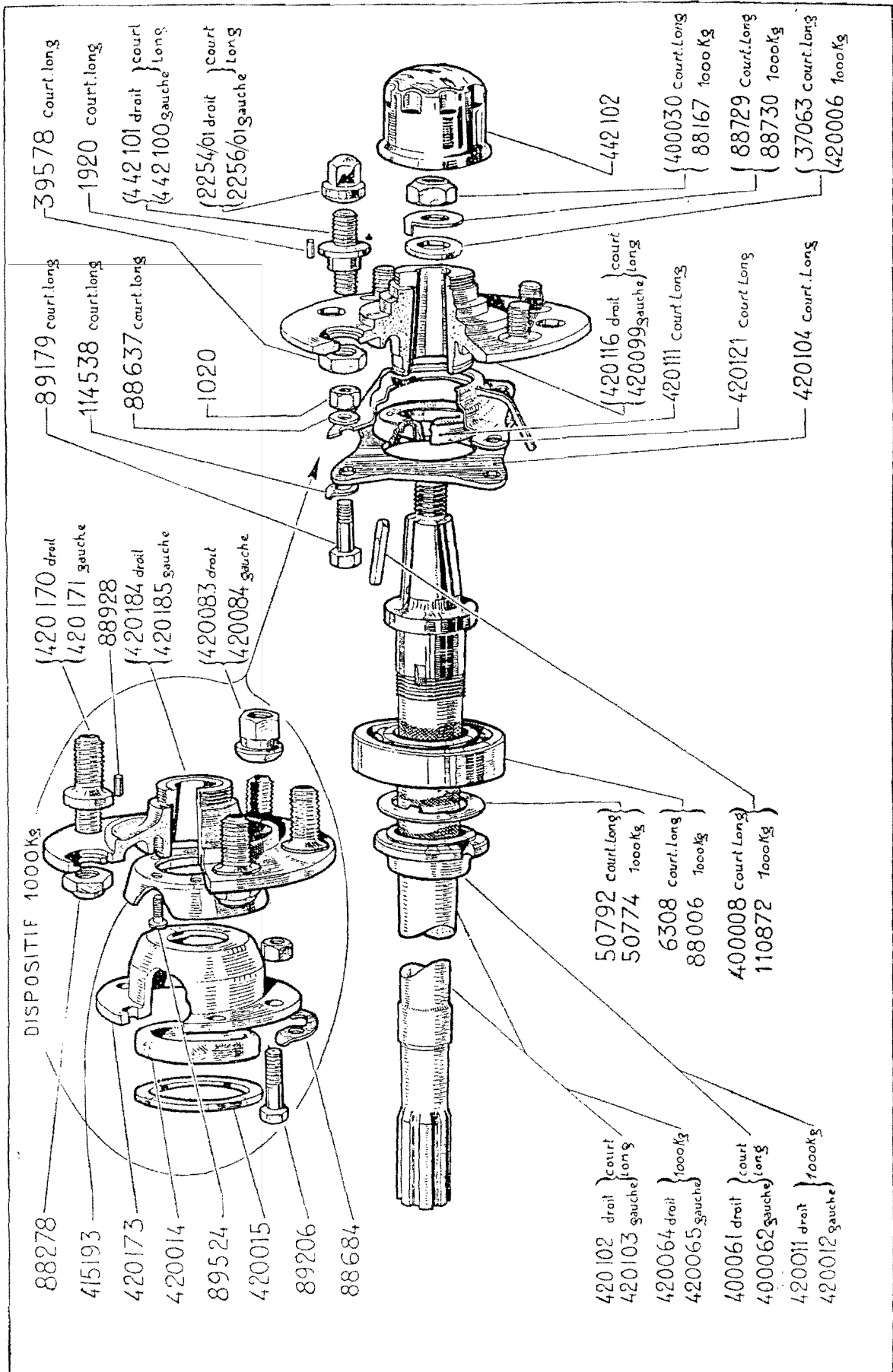



ESSIEU AV

CORPS D'ESSIEU
FUSÉES - MOYEURS

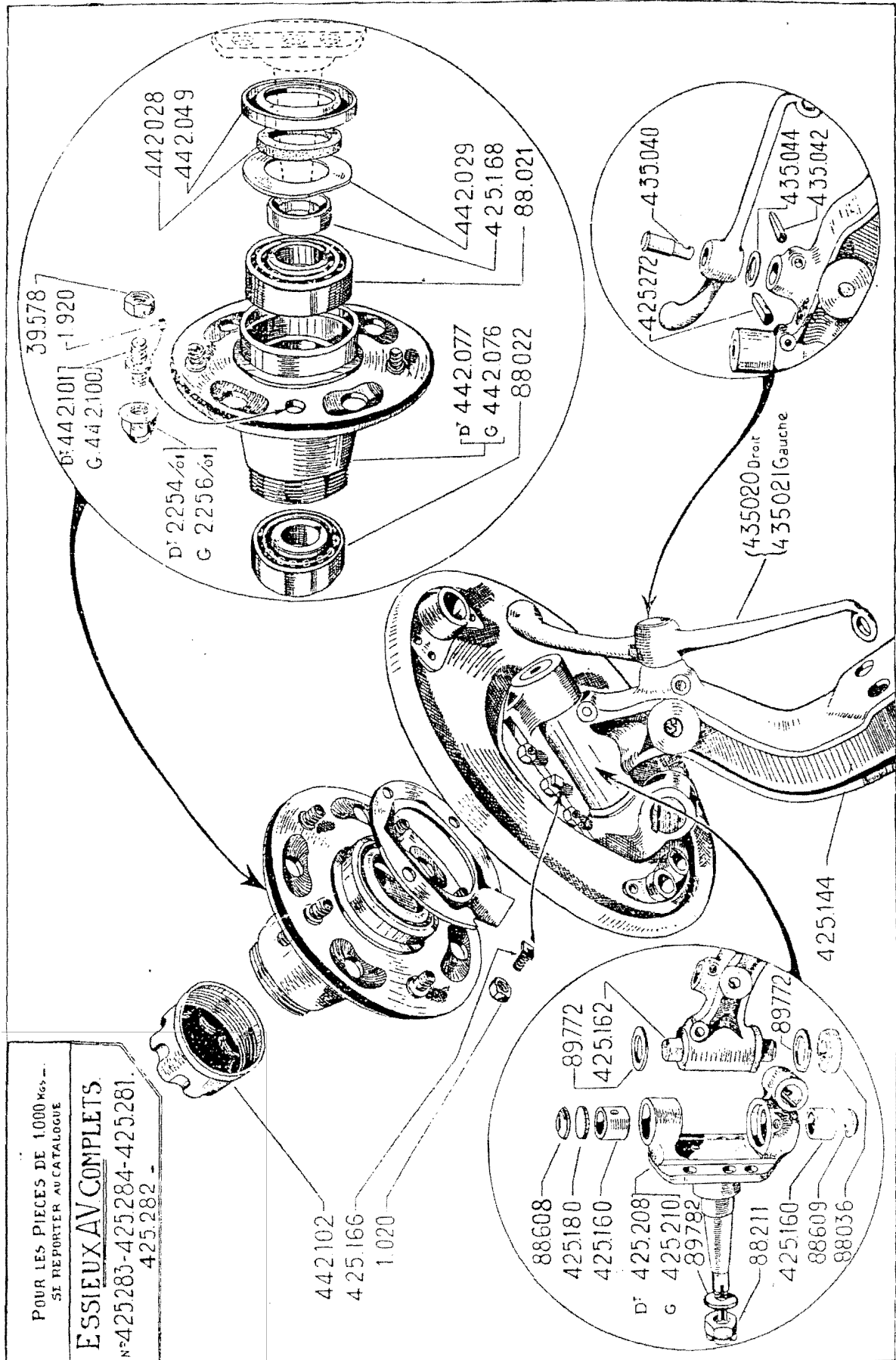

POUR LES PIÈCES DE 1000 Kgs -
SE REPORTER AU CATALOGUE

ESSIEUX AV COMPLETS

N° 425283-425284-425281.

425282 -



ESSIEU AV

BARRES DE DIRECTION D'ACCOUPLMENT, LEVIERS

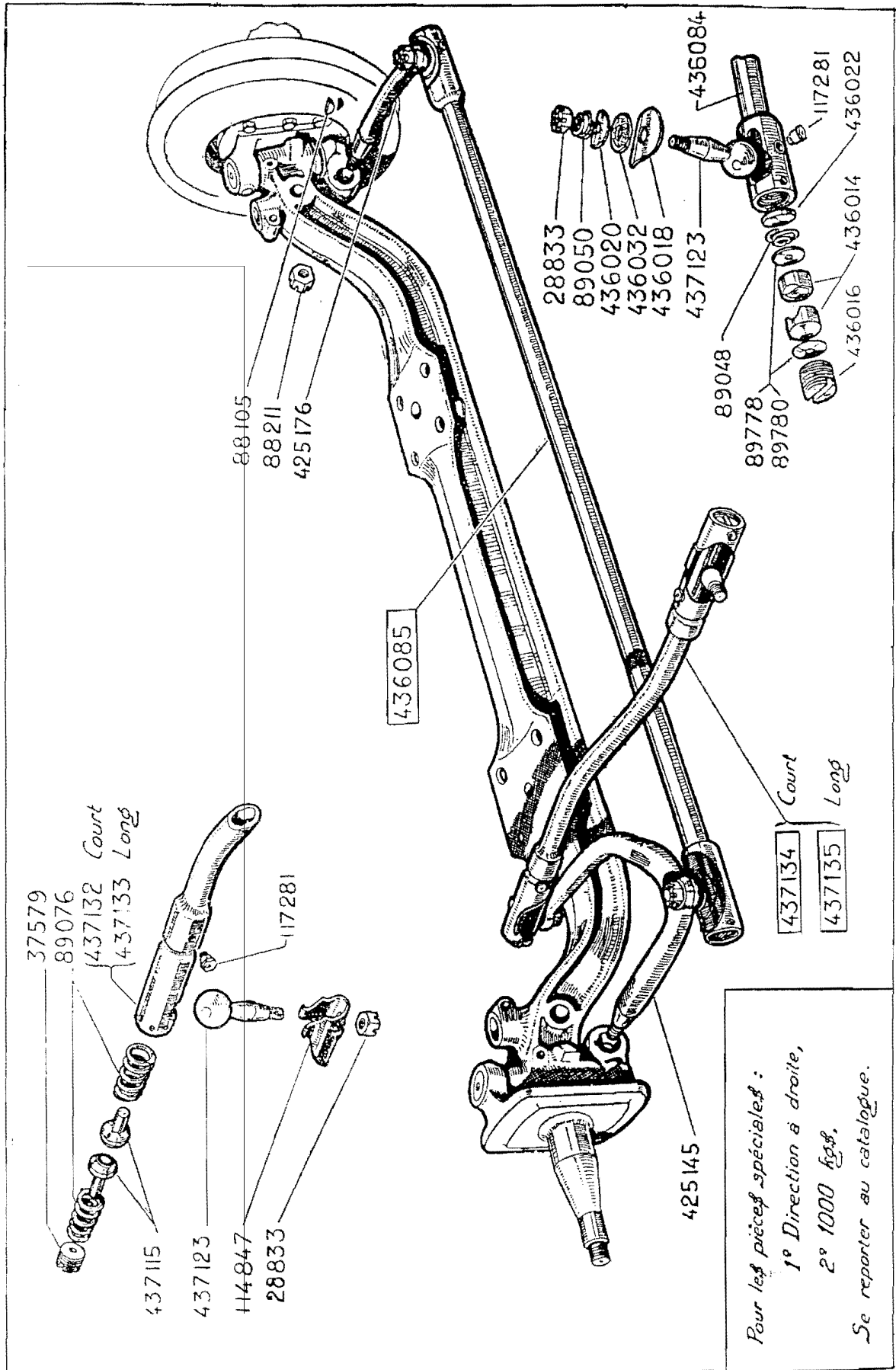



FREINS

PÉDALIER - ARBRE DE RENVOI DE FREINS

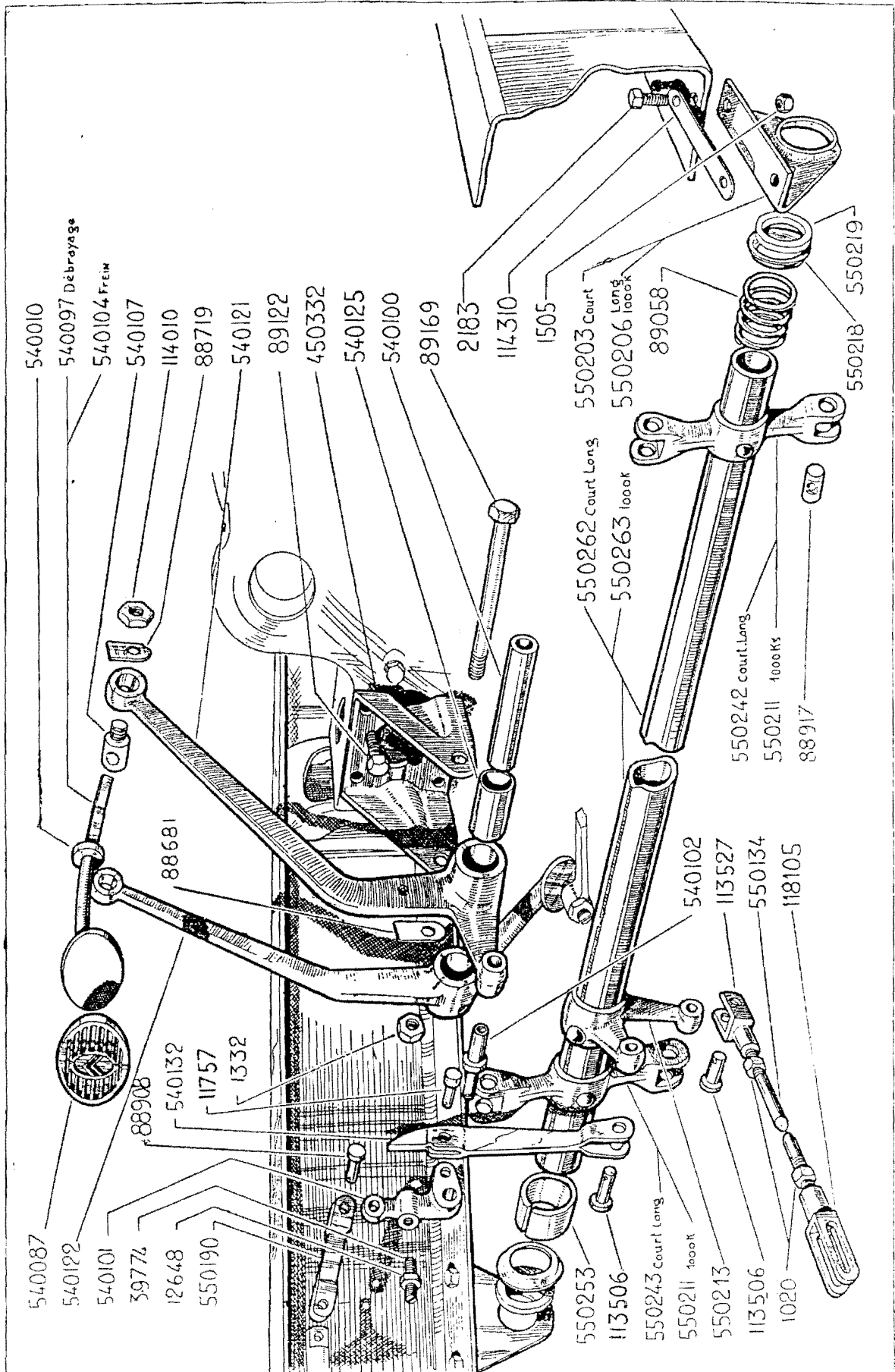



FREINS

TAMBOURS - SEGMENTS

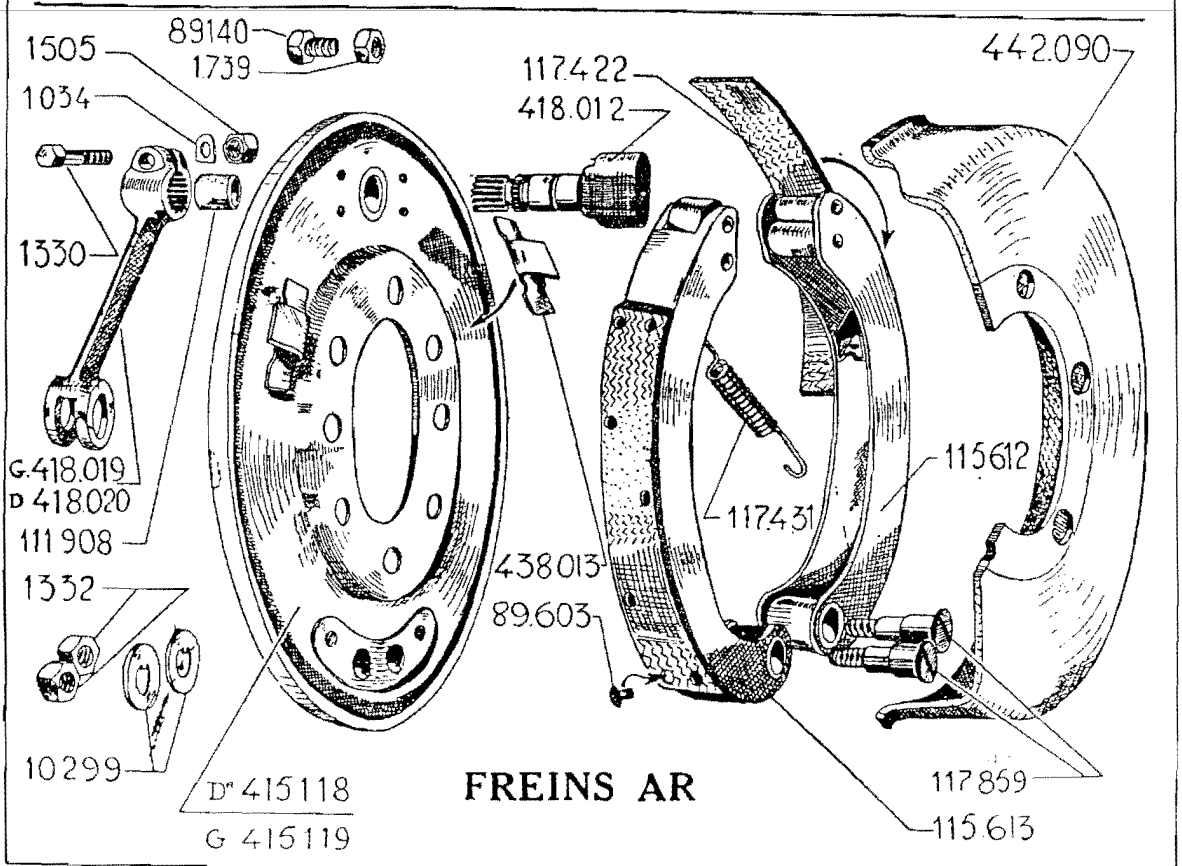
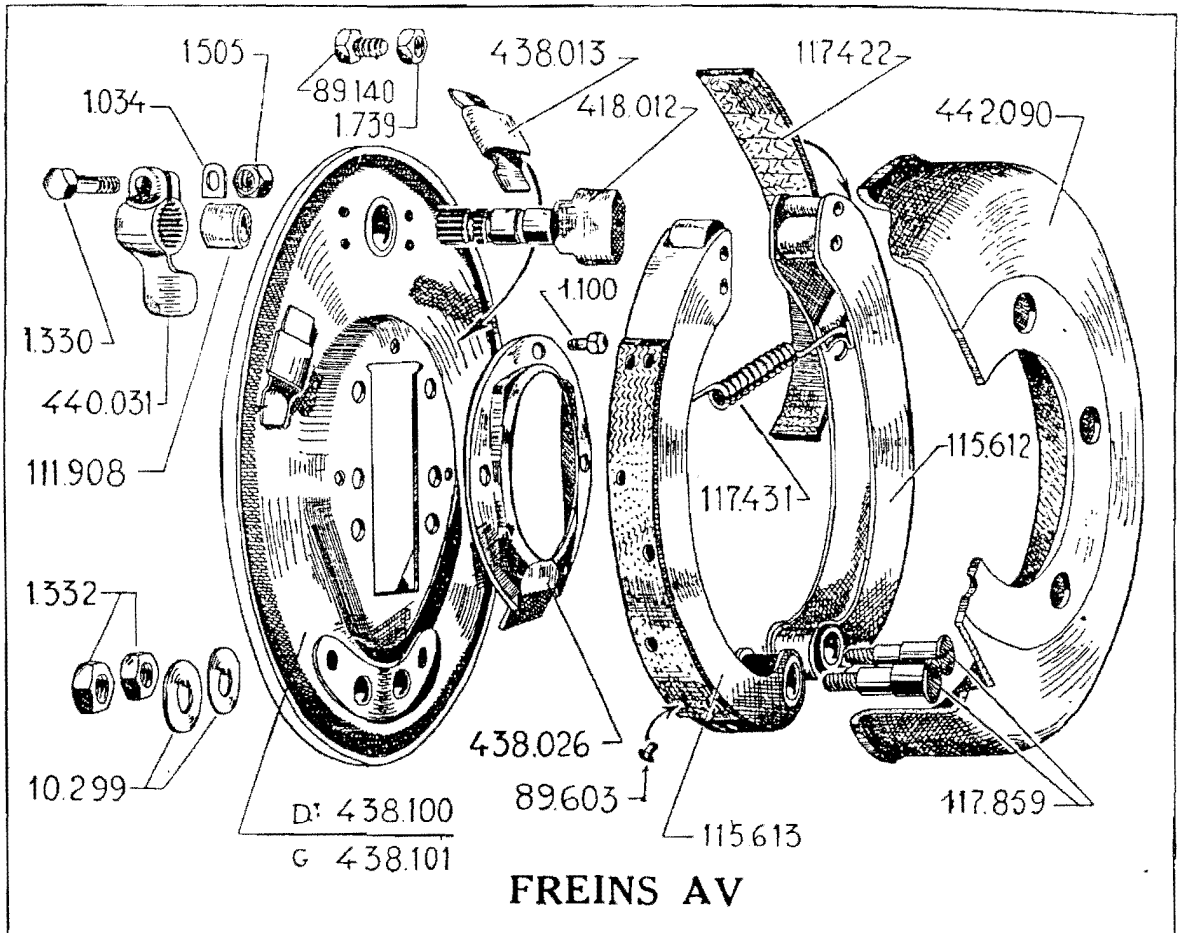



FREINS

SERVO-FREIN

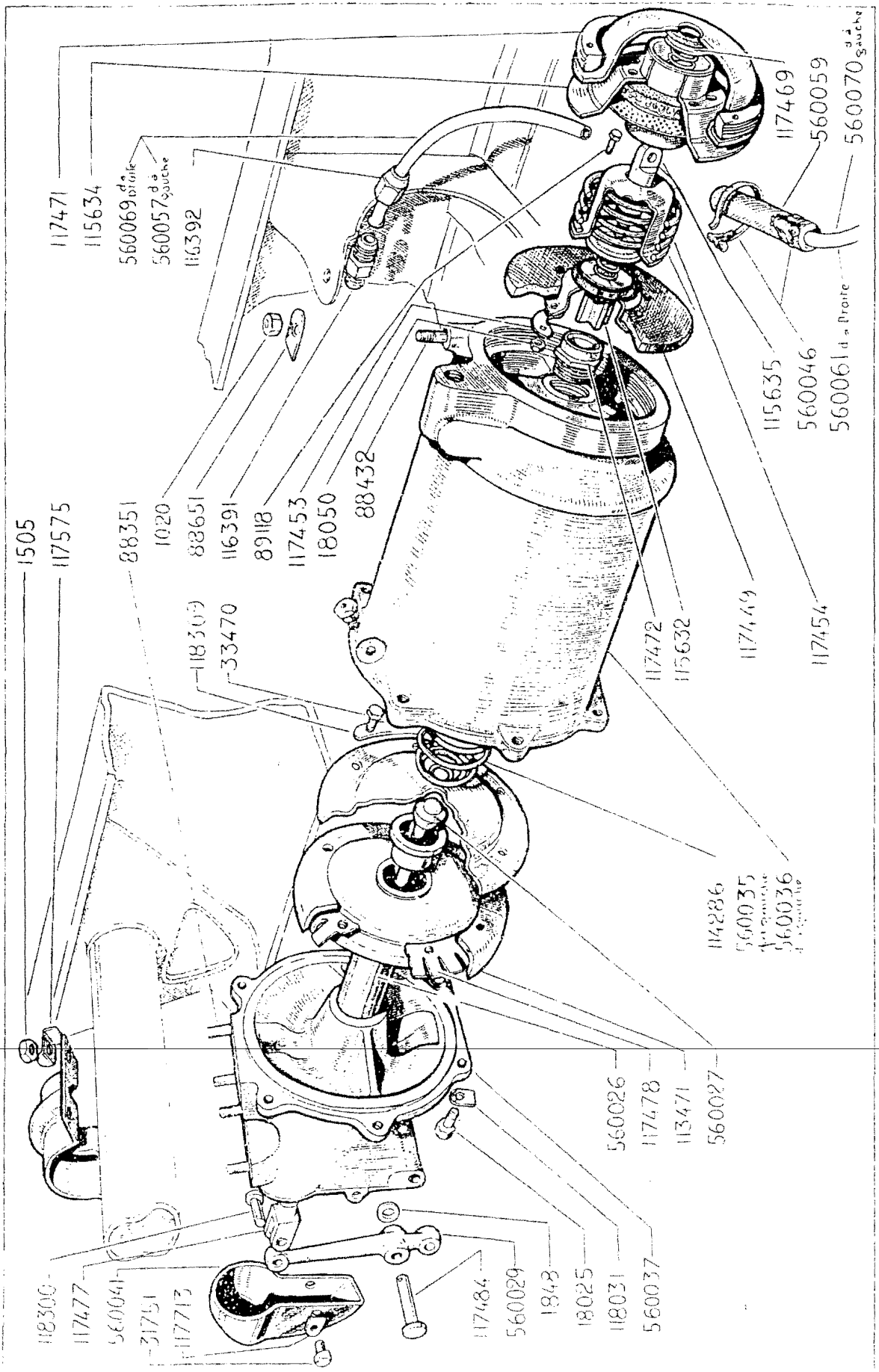



CHASSIS

ALIMENTATION D'ESSENCE

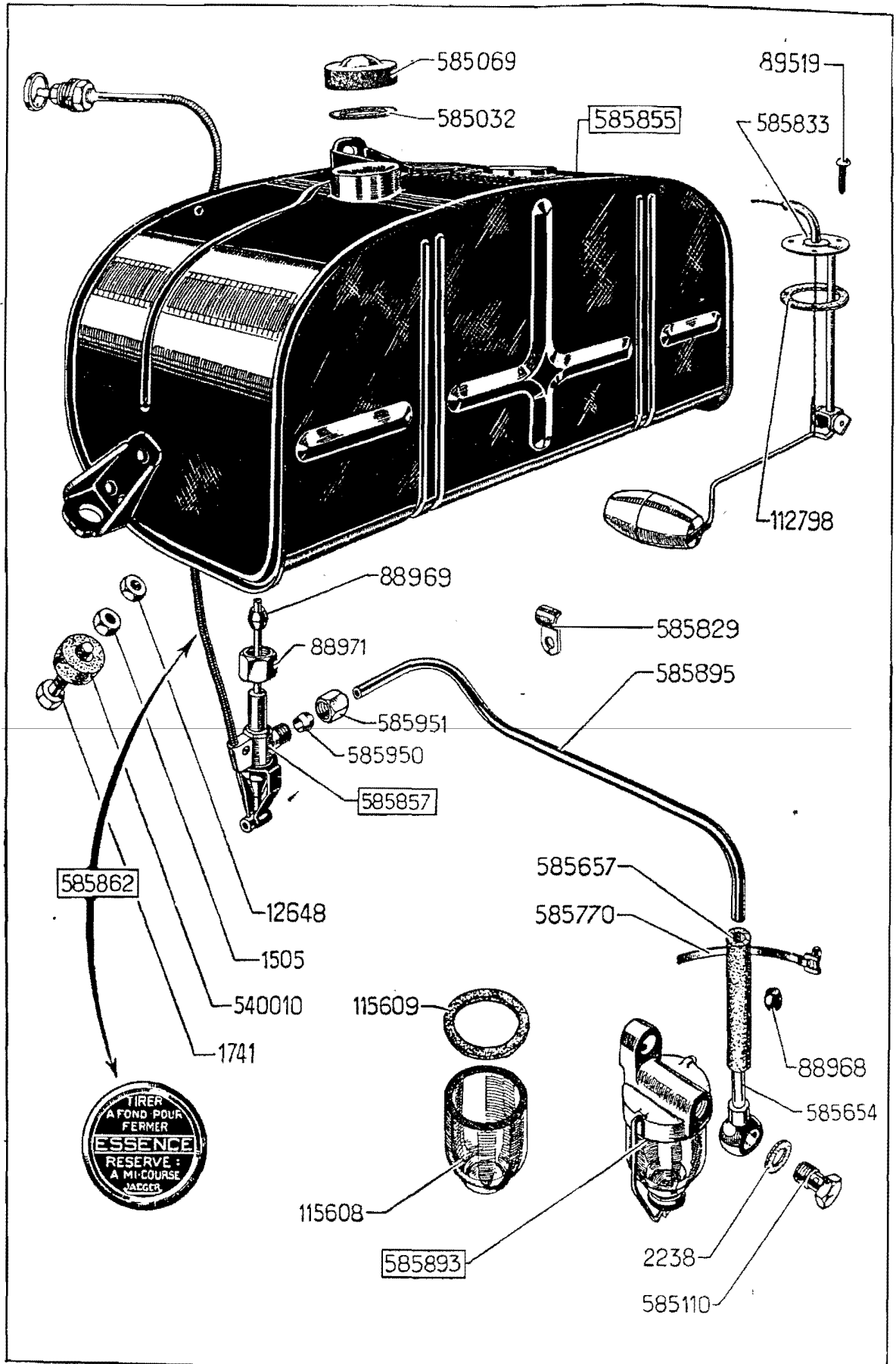

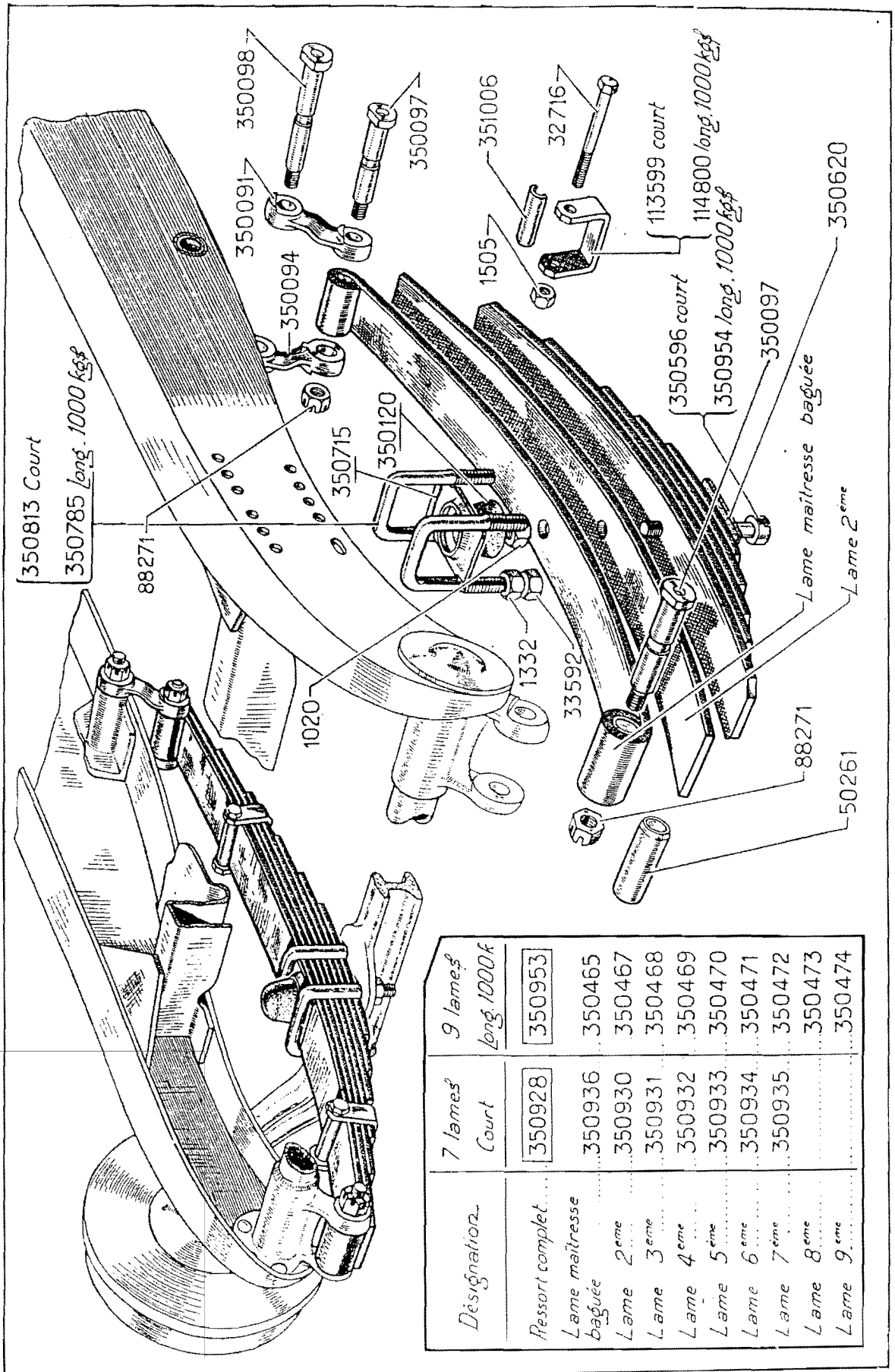

Designation	7 lames Court	9 lames long. 1000k
Ressort complet	350928	350953
Lame maitresse baguée	350936	350465
Lame 2 ^{ème}	350930	350467
Lame 3 ^{ème}	350931	350468
Lame 4 ^{ème}	350932	350469
Lame 5 ^{ème}	350933	350470
Lame 6 ^{ème}	350934	350471
Lame 7 ^{ème}	350935	350472
Lame 8 ^{ème}		350473
Lame 9 ^{ème}		350474



CHASSIS

ÉLASTIQUE DU MOTEUR PANIER D'ACCUS

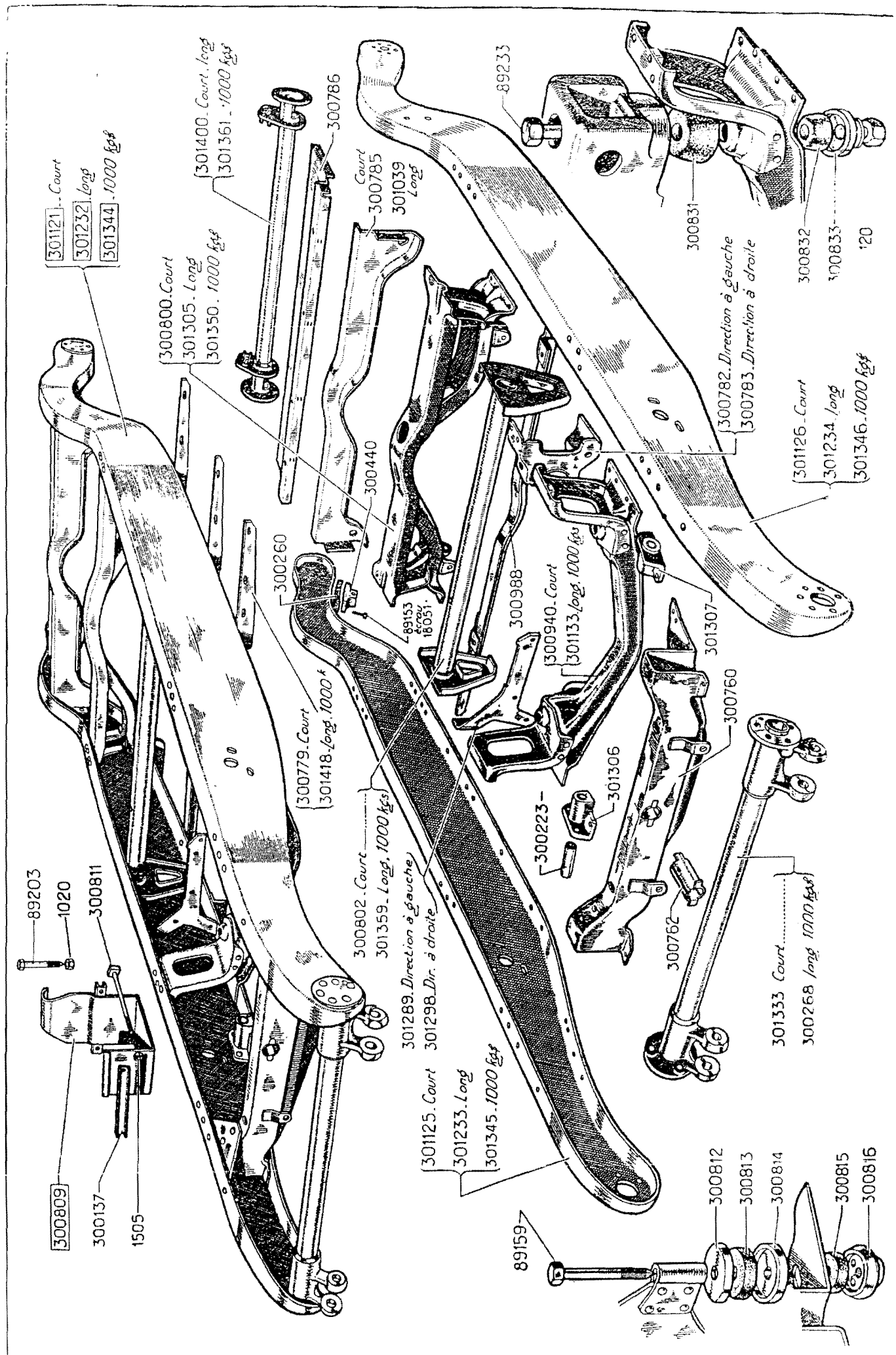



SUSPENSION

SUSPENSION AR

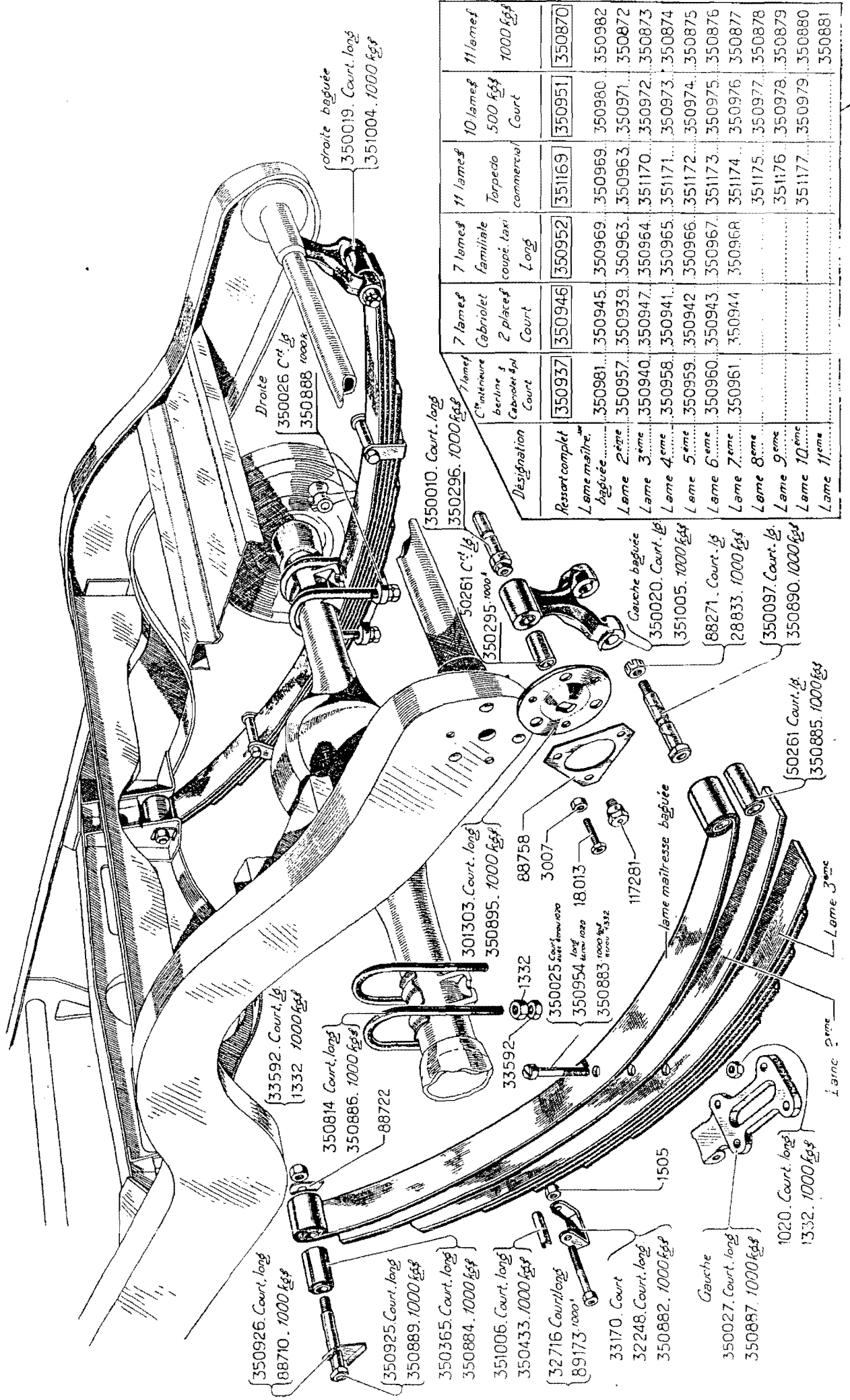



ÉLECTRICITÉ

COMMANDE DE COMMUTATEUR COMMUTATEUR MONOBLOC

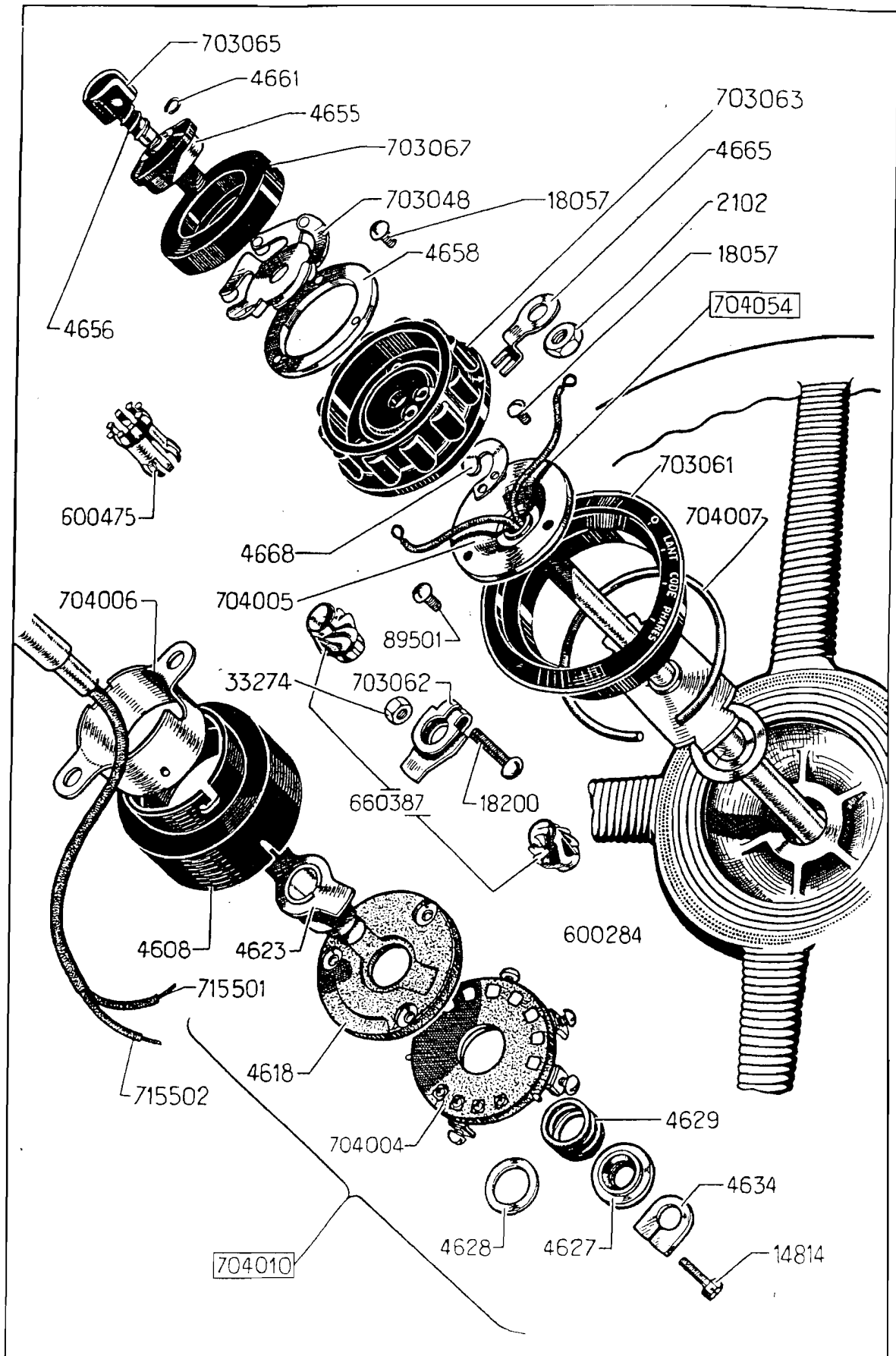



ÉLECTRICITÉ

COMMANDE DE DÉMARREUR, DE RALENTI ET DE VOILET D'AIR

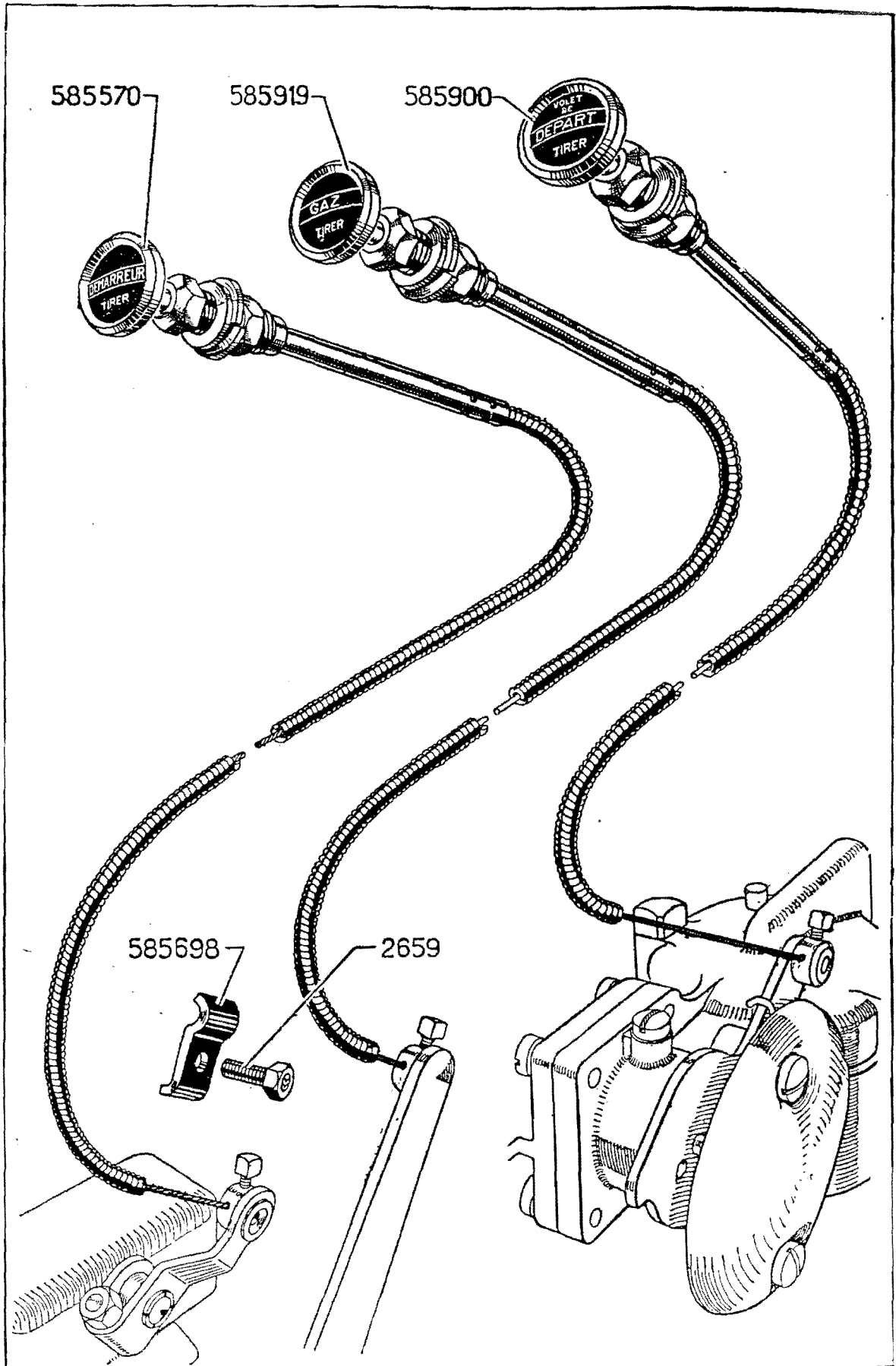

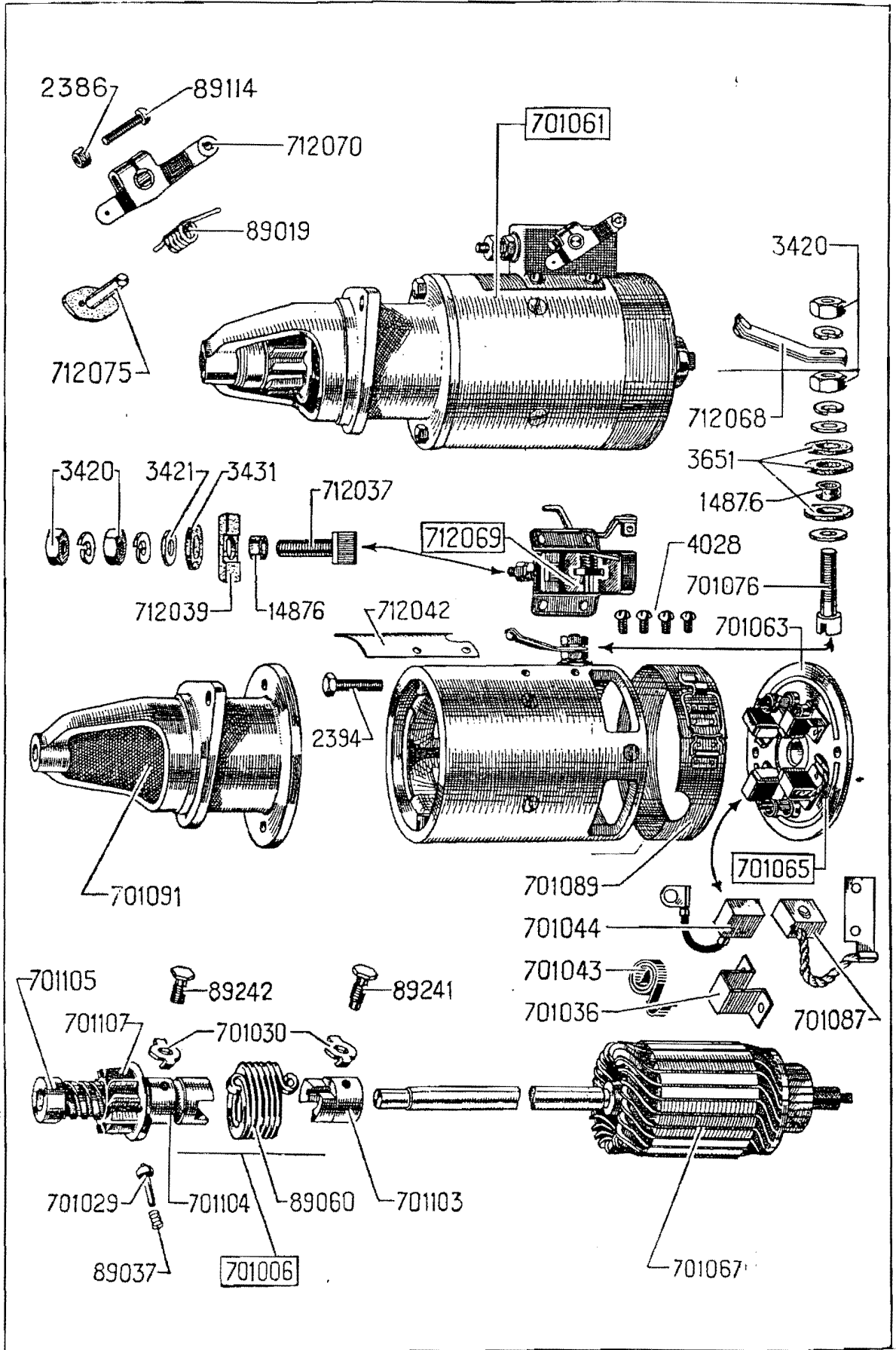

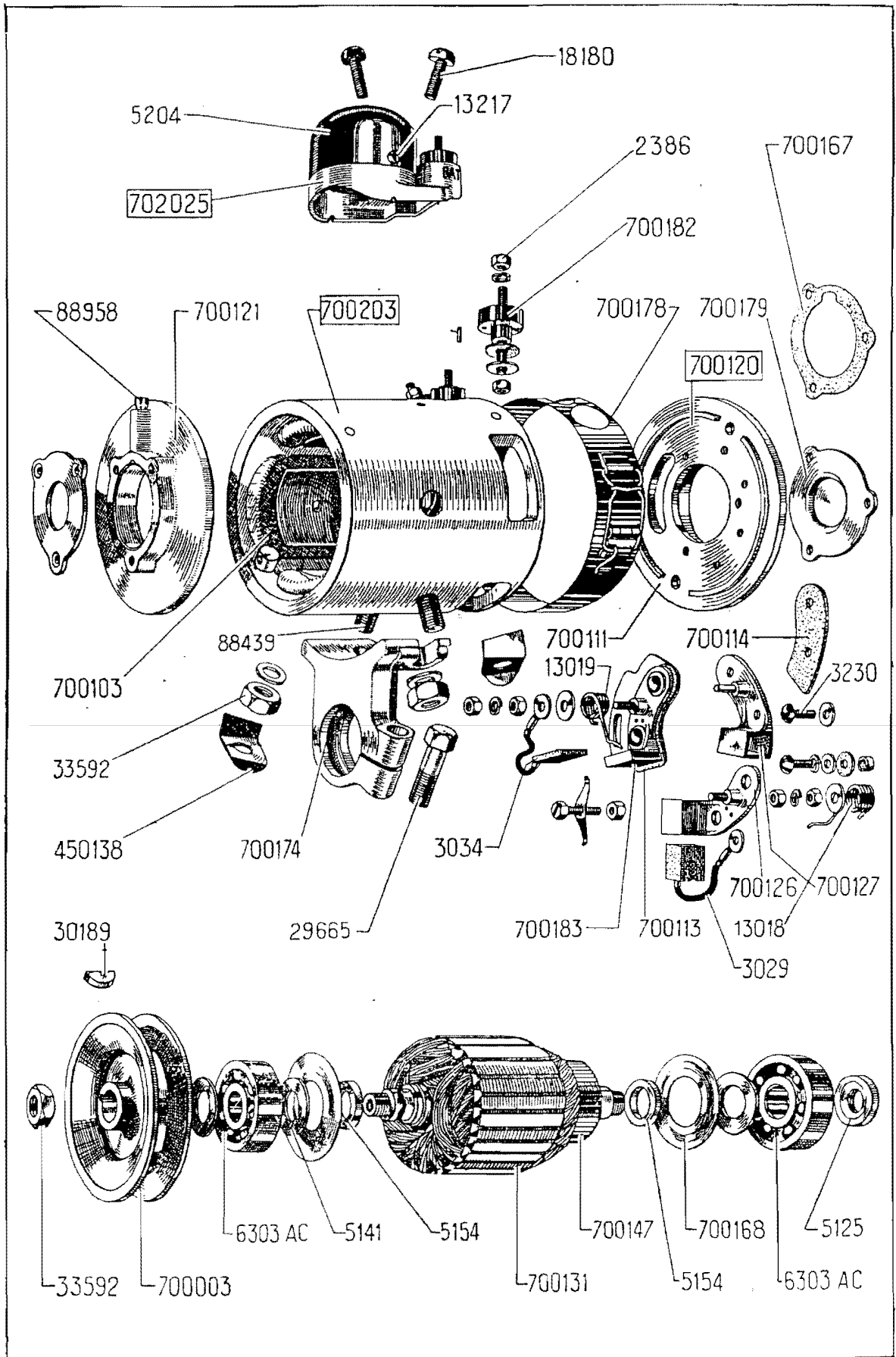

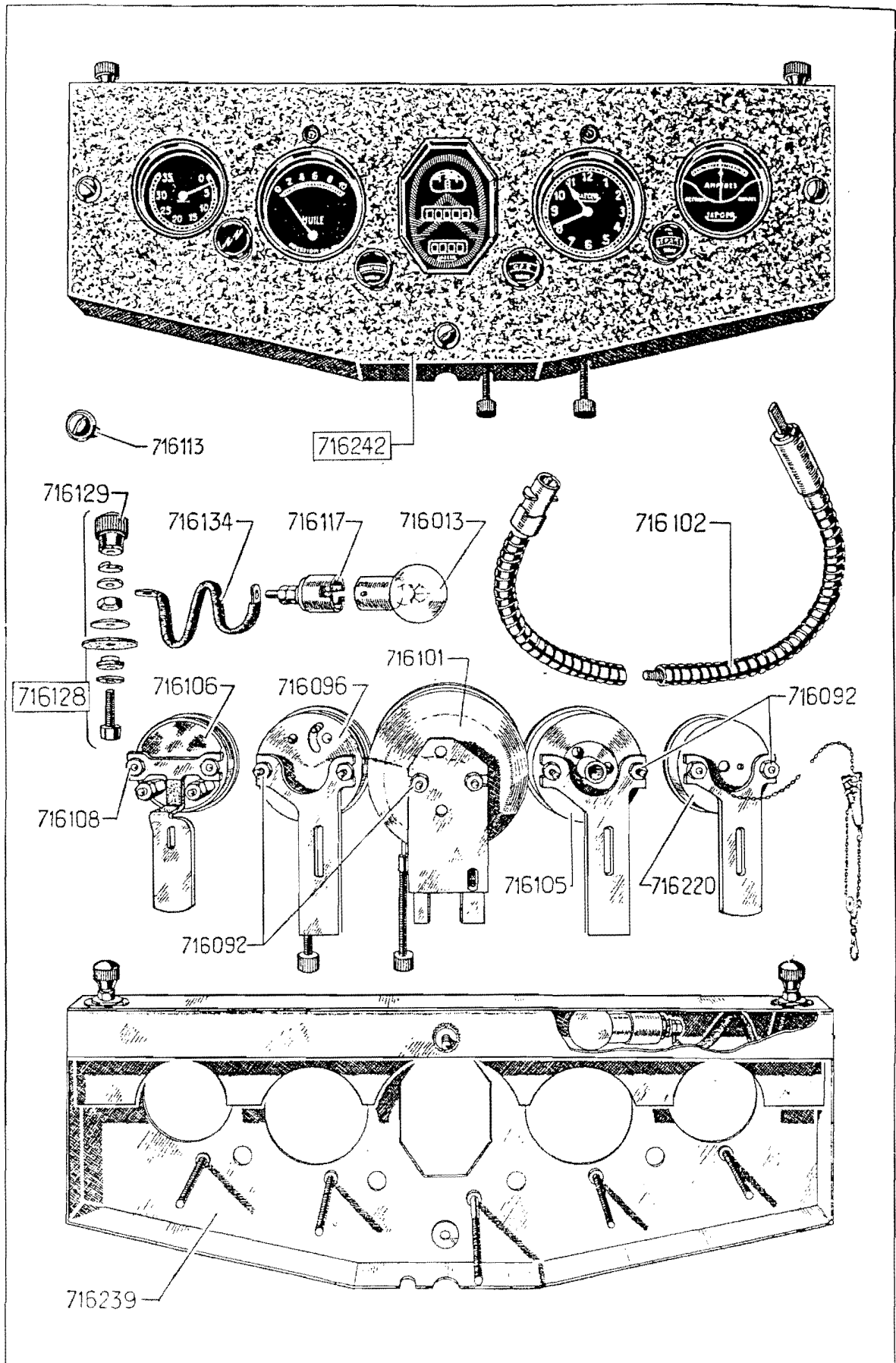

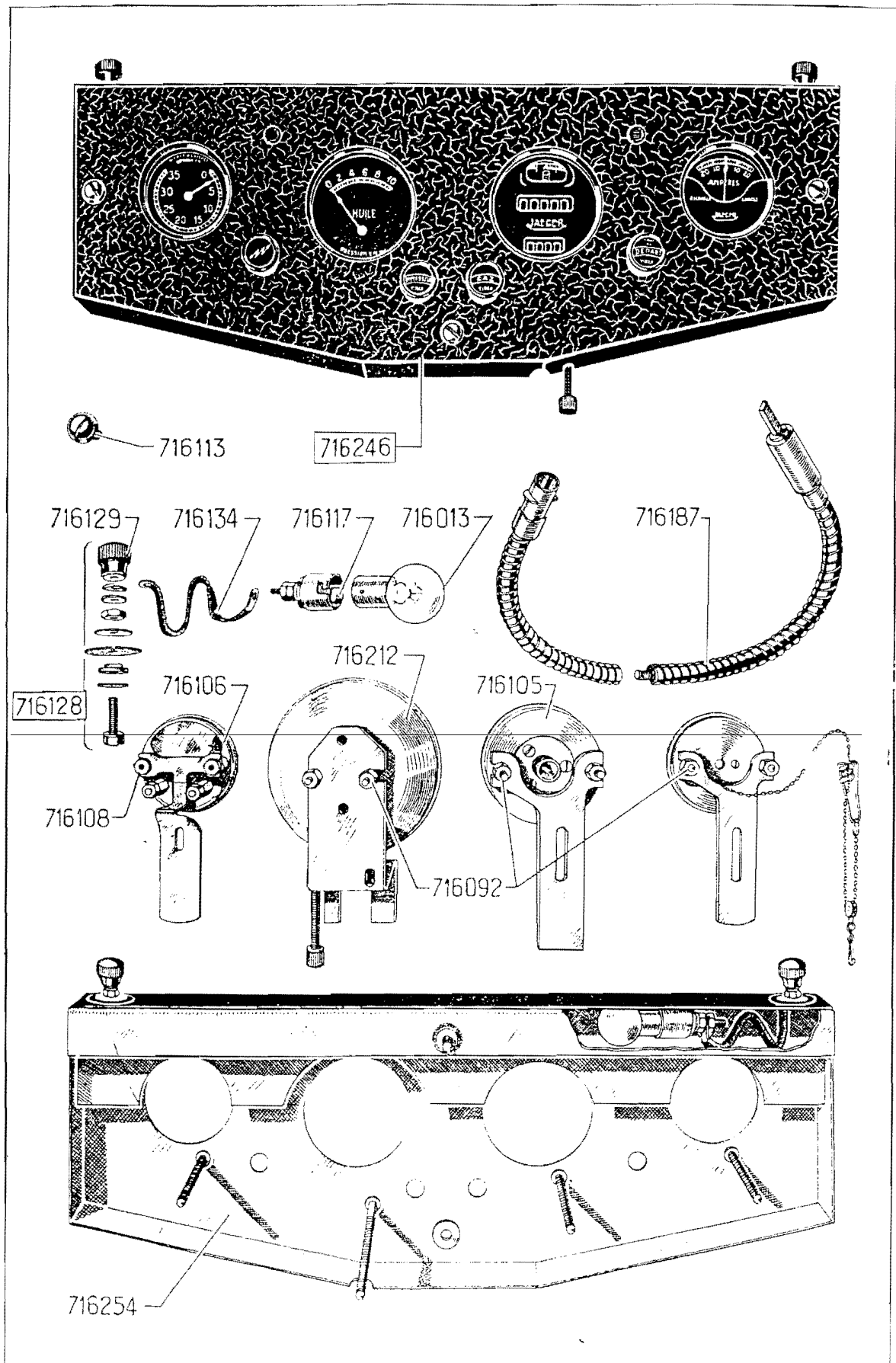

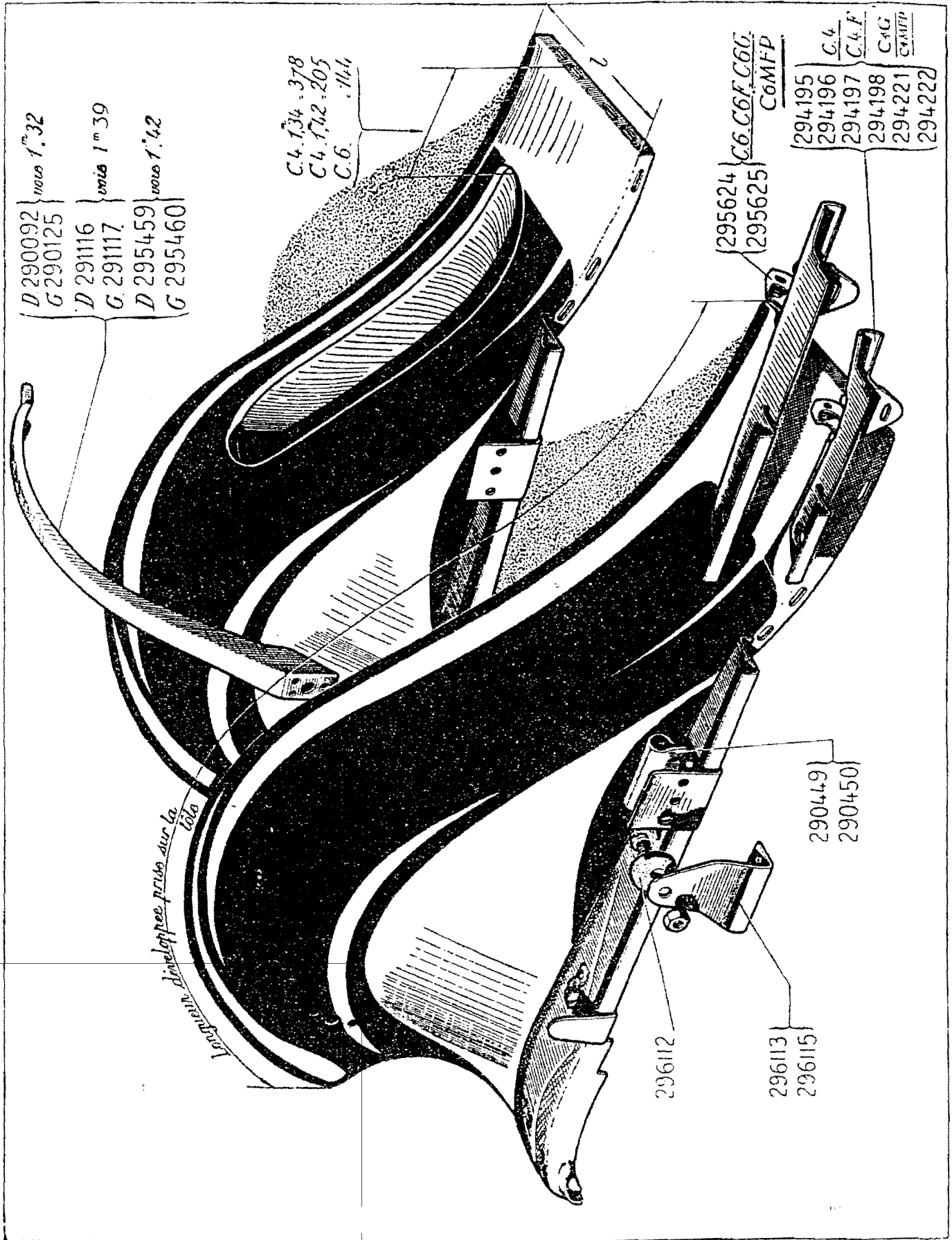

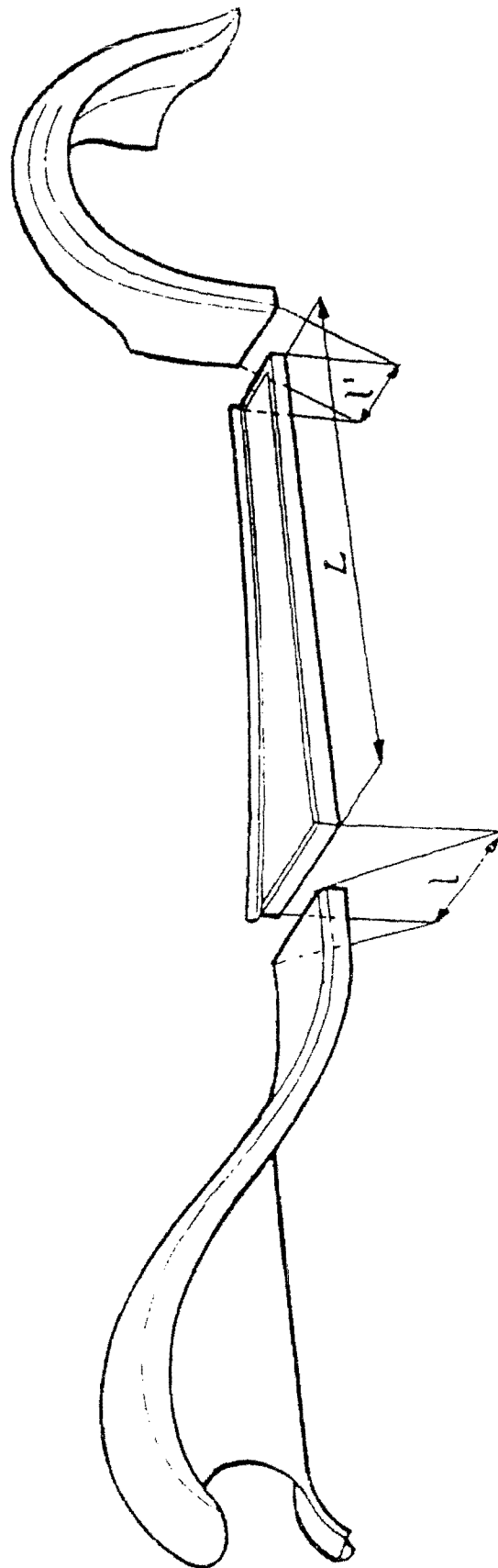

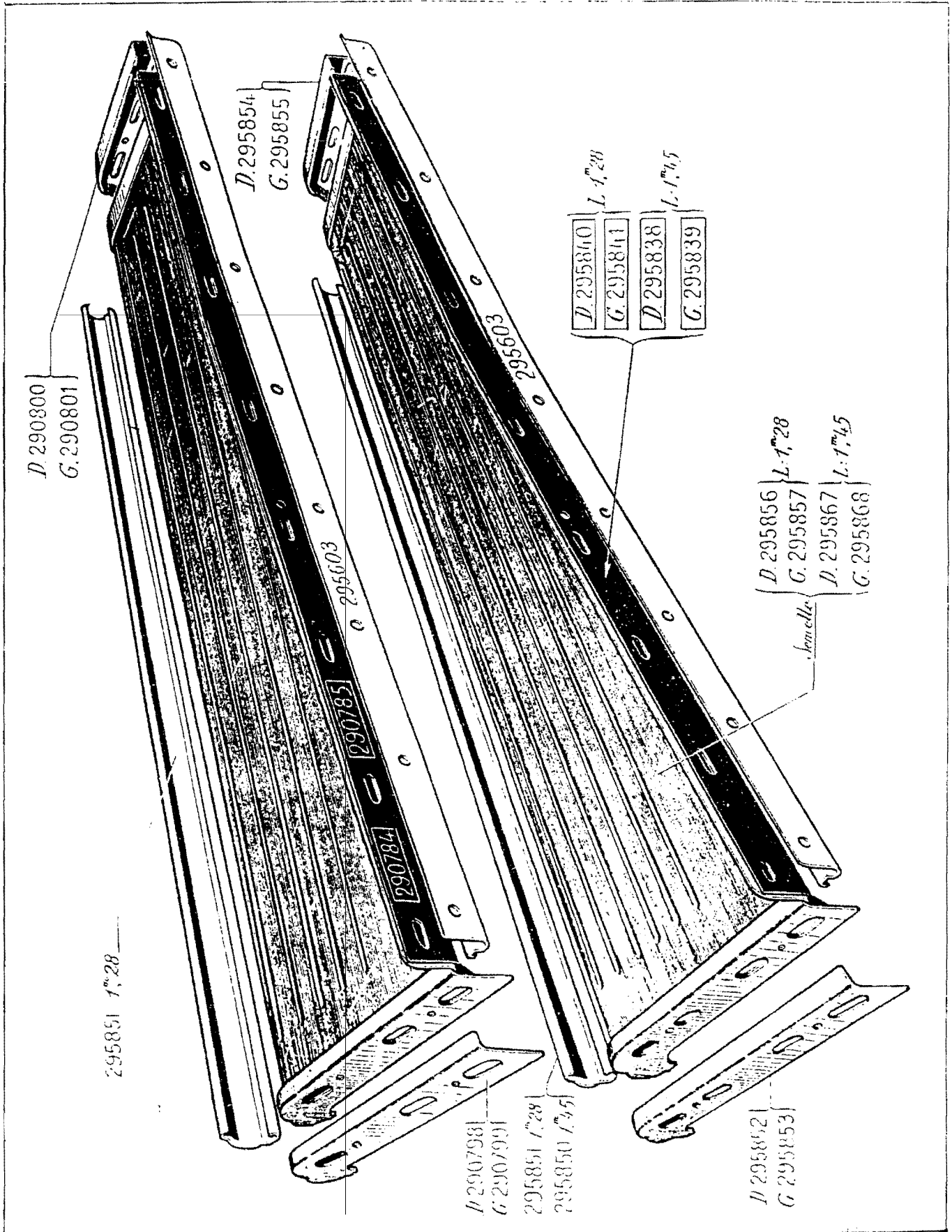



1^{er} dispat
D. 295104 | voie 1^{er} 32
G. 295105
D. 294071 | voie 1^{er} 39
G. 294072
D. 295080 | voie 1^{er} 32
G. 295081
D. 299003 | voie 1^{er} 39
G. 299004

2^e dispat
D. 294105 | voie 1^{er} 39
G. 294106
D. 295255 | voie 1^{er} 32
G. 295256
D. 299025 | voie 1^{er} 39
G. 299026

3^e dispat
D. 290529 | voie 1^{er} 32
G. 290530
D. 290541 | voie 1^{er} 42
G. 290542
D. 290552 | voie 1^{er} 42
G. 290553

Encad. en 1^{re} pièce
D. 295042 | 1^{er} 32
G. 295043
D. 294014 | 1^{er} 39
G. 294015
D. 299013 | 1^{er} 39
G. 299014
D. 295089 | 1^{er} 32
G. 295090
295604 (L. 1^{er} 45)

Semelle de marche pieds
340*250 | 360*270 | 390*300
caout. D 295102 | 294069
G 295103 | 294070
Bl. Rub. D 290564
G 290565
caout. D 295091 | 299015
G 295092 | 299016
Bl. Rub. D | 295647
G | 295648
D | 295649
G | 295650

couche
L. 1^{er} 28
L. 1^{er} 45

caoutchouc
A
B

Black Rubber

Coupe de profil de semelle

1^{er} dispat
D. 295104 | voie 1^{er} 32
G. 295105
D. 294071 | voie 1^{er} 39
G. 294072
D. 295080 | voie 1^{er} 32
G. 295081
D. 299003 | voie 1^{er} 39
G. 299004

2^e dispat
D. 294105 | voie 1^{er} 39
G. 294106
D. 295255 | voie 1^{er} 32
G. 295256
D. 299025 | voie 1^{er} 39
G. 299026

3^e dispat
D. 290529 | voie 1^{er} 32
G. 290530
D. 290541 | voie 1^{er} 42
G. 290542
D. 290552 | voie 1^{er} 42
G. 290553

Encad. en 1^{re} pièce
D. 295042 | 1^{er} 32
G. 295043
D. 294014 | 1^{er} 39
G. 294015
D. 299013 | 1^{er} 39
G. 299014
D. 295089 | 1^{er} 32
G. 295090
295604 (L. 1^{er} 45)

Semelle de marche pieds
340*250 | 360*270 | 390*300
caout. D 295102 | 294069
G 295103 | 294070
Bl. Rub. D 290564
G 290565
caout. D 295091 | 299015
G 295092 | 299016
Bl. Rub. D | 295647
G | 295648
D | 295649
G | 295650

couche
L. 1^{er} 28
L. 1^{er} 45

caoutchouc
A
B

Black Rubber

Coupe de profil de semelle

1^{er} dispat
D. 295104 | voie 1^{er} 32
G. 295105
D. 294071 | voie 1^{er} 39
G. 294072
D. 295080 | voie 1^{er} 32
G. 295081
D. 299003 | voie 1^{er} 39
G. 299004

2^e dispat
D. 294105 | voie 1^{er} 39
G. 294106
D. 295255 | voie 1^{er} 32
G. 295256
D. 299025 | voie 1^{er} 39
G. 299026

3^e dispat
D. 290529 | voie 1^{er} 32
G. 290530
D. 290541 | voie 1^{er} 42
G. 290542
D. 290552 | voie 1^{er} 42
G. 290553

Encad. en 1^{re} pièce
D. 295042 | 1^{er} 32
G. 295043
D. 294014 | 1^{er} 39
G. 294015
D. 299013 | 1^{er} 39
G. 299014
D. 295089 | 1^{er} 32
G. 295090
295604 (L. 1^{er} 45)

Semelle de marche pieds
340*250 | 360*270 | 390*300
caout. D 295102 | 294069
G 295103 | 294070
Bl. Rub. D 290564
G 290565
caout. D 295091 | 299015
G 295092 | 299016
Bl. Rub. D | 295647
G | 295648
D | 295649
G | 295650

couche
L. 1^{er} 28
L. 1^{er} 45

caoutchouc
A
B

Black Rubber

Coupe de profil de semelle

1^{er} dispat
D. 295104 | voie 1^{er} 32
G. 295105
D. 294071 | voie 1^{er} 39
G. 294072
D. 295080 | voie 1^{er} 32
G. 295081
D. 299003 | voie 1^{er} 39
G. 299004

2^e dispat
D. 294105 | voie 1^{er} 39
G. 294106
D. 295255 | voie 1^{er} 32
G. 295256
D. 299025 | voie 1^{er} 39
G. 299026

3^e dispat
D. 290529 | voie 1^{er} 32
G. 290530
D. 290541 | voie 1^{er} 42
G. 290542
D. 290552 | voie 1^{er} 42
G. 290553

Encad. en 1^{re} pièce
D. 295042 | 1^{er} 32
G. 295043
D. 294014 | 1^{er} 39
G. 294015
D. 299013 | 1^{er} 39
G. 299014
D. 295089 | 1^{er} 32
G. 295090
295604 (L. 1^{er} 45)

Semelle de marche pieds
340*250 | 360*270 | 390*300
caout. D 295102 | 294069
G 295103 | 294070
Bl. Rub. D 290564
G 290565
caout. D 295091 | 299015
G 295092 | 299016
Bl. Rub. D | 295647
G | 295648
D | 295649
G | 295650

couche
L. 1^{er} 28
L. 1^{er} 45

caoutchouc
A
B

Black Rubber

Coupe de profil de semelle

D. 290532 | v. 1^{er} 34
G. 290533
D. 290548 | v. 1^{er} 42
G. 290549

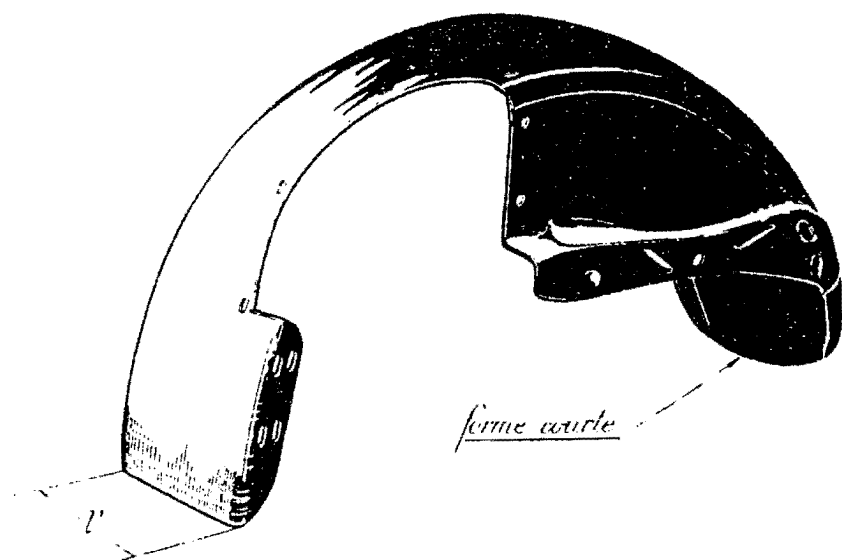
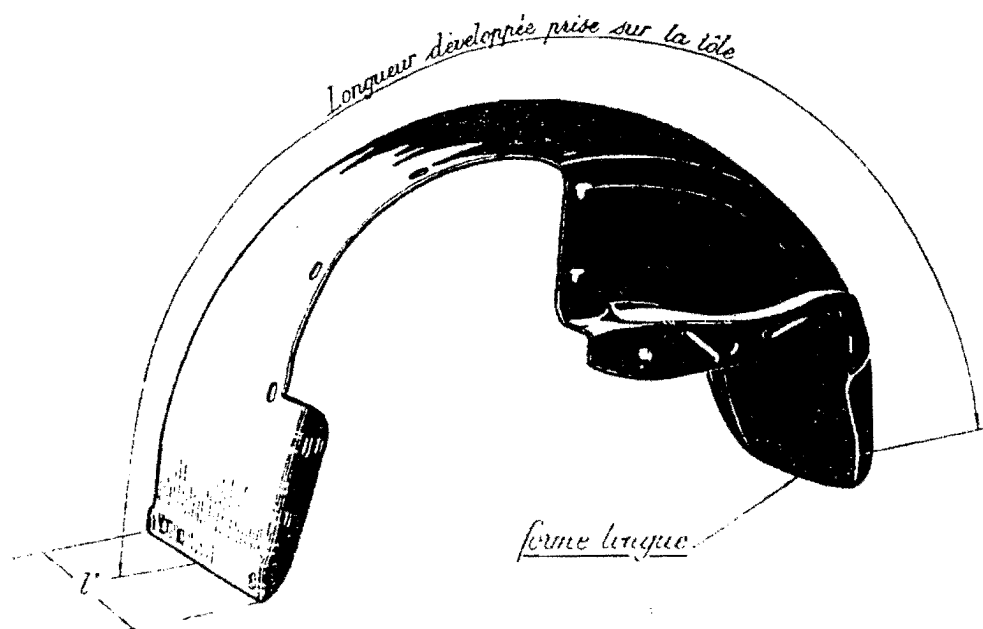

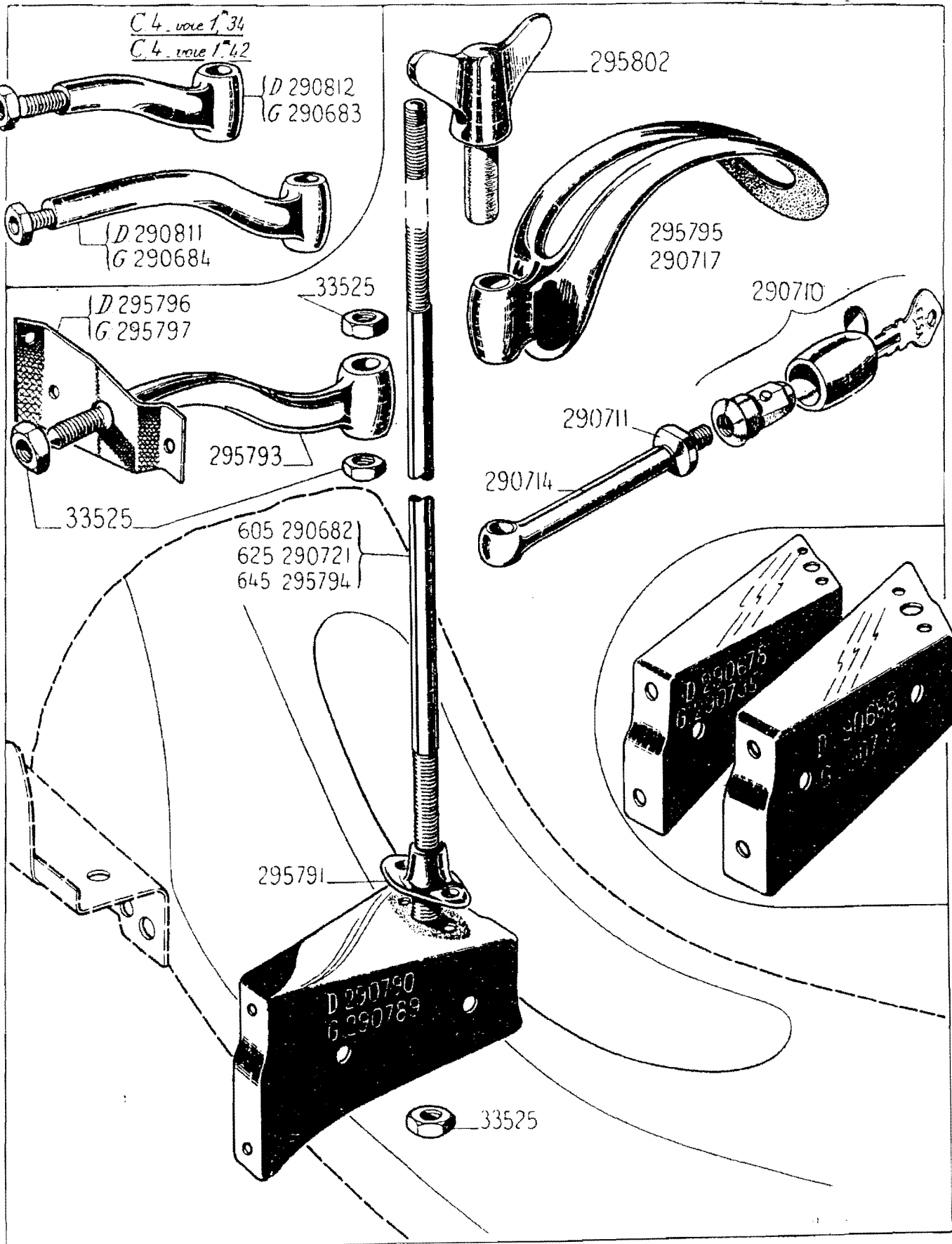

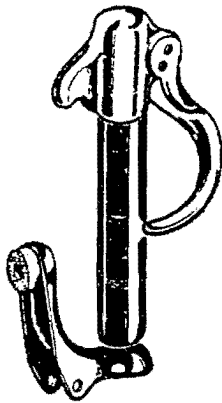

295582

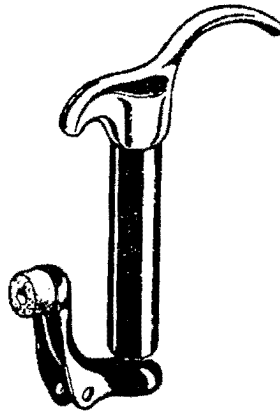

291703

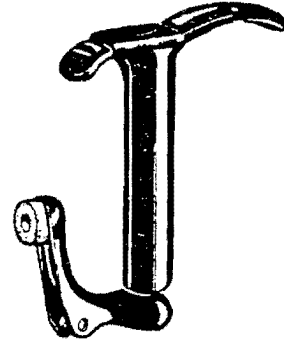

291124

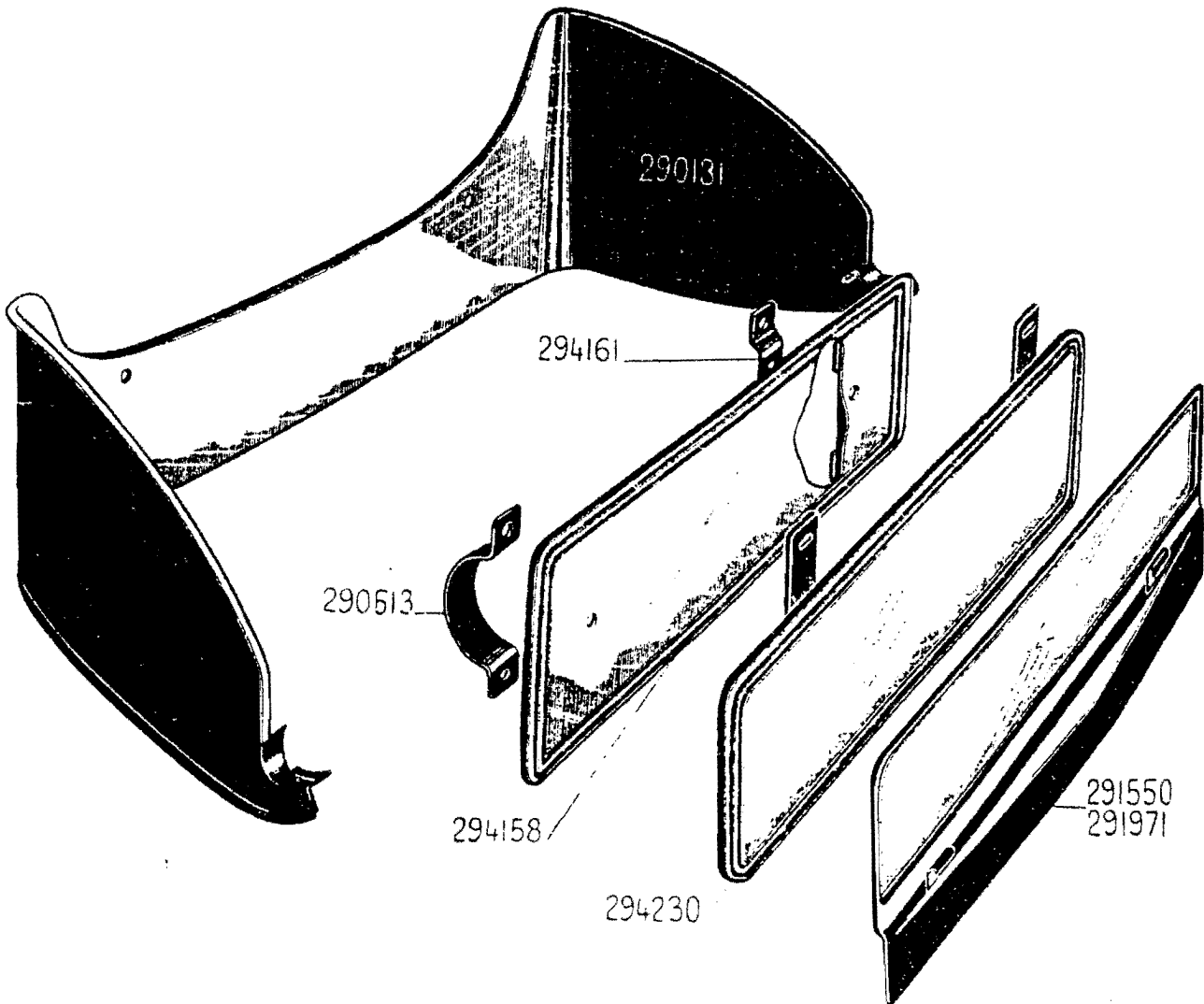

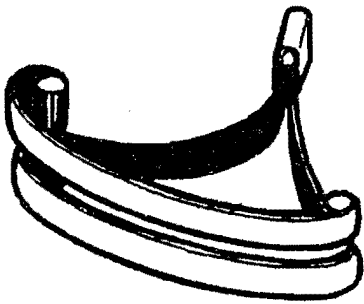
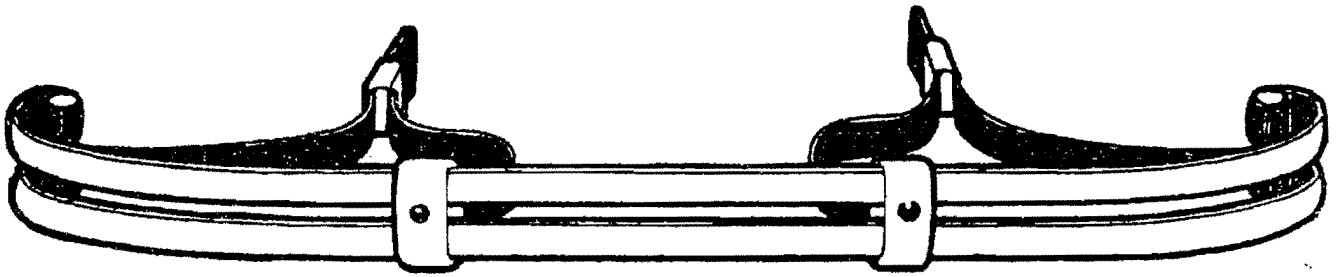

A LAMES

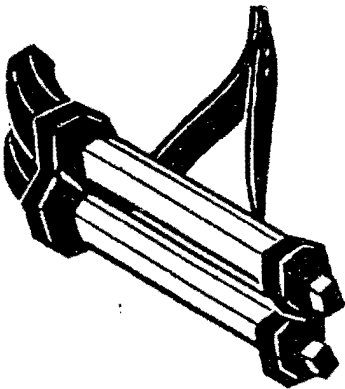
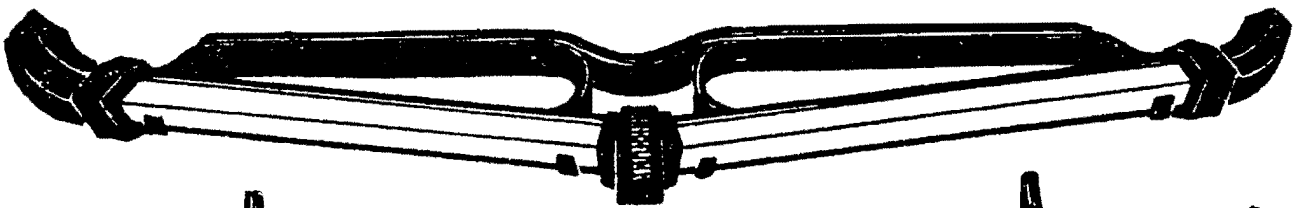
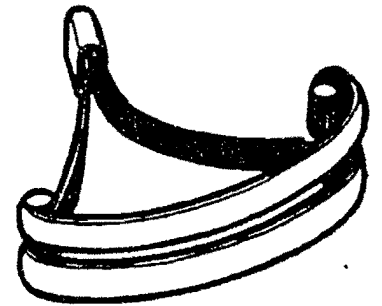

LIC^{CE} CROMOS

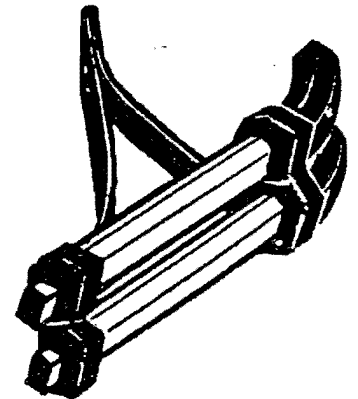

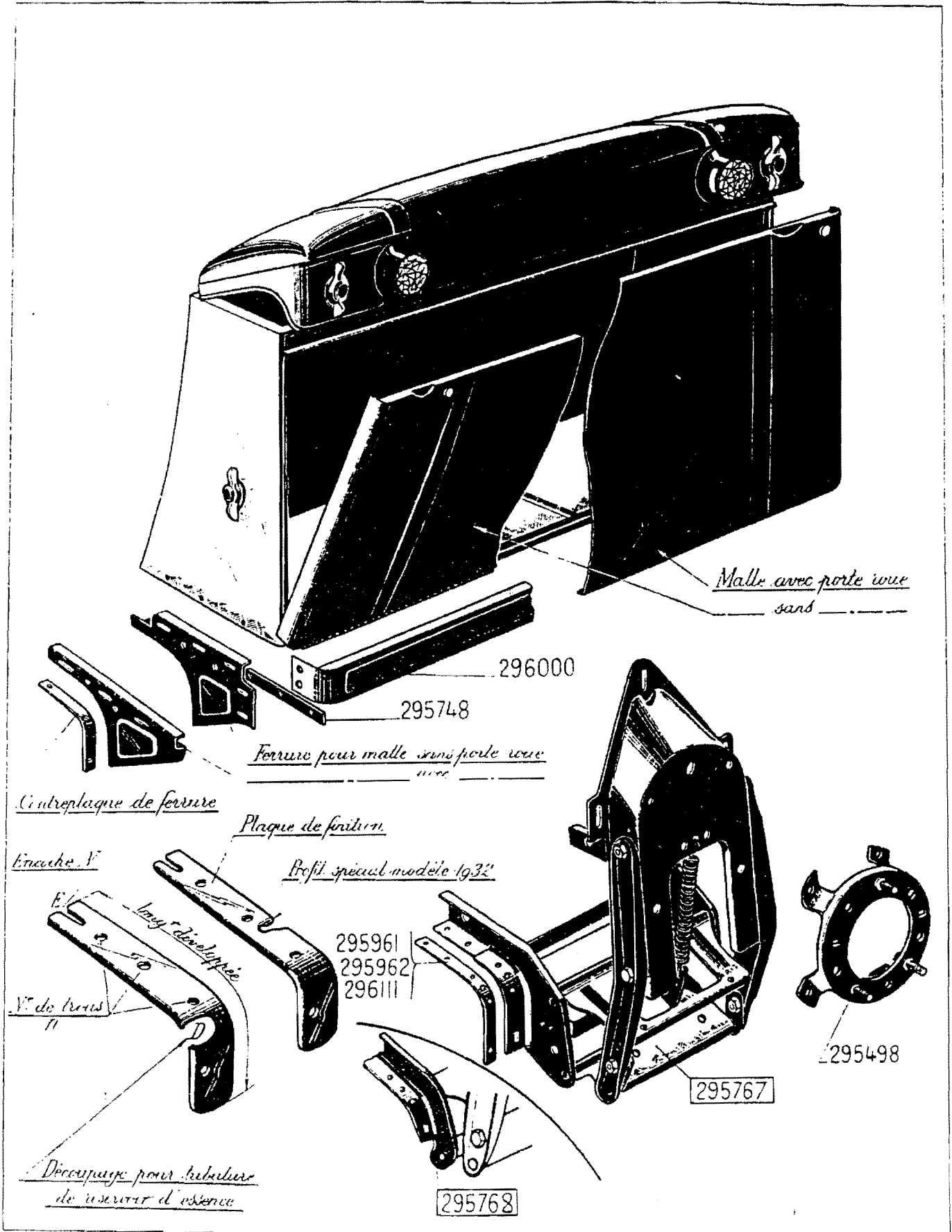



PARE-BRISE

PARE-BRISE EN 1 PIECE
C4, C6, 8, 10, 15 CV (Voitures fermées)

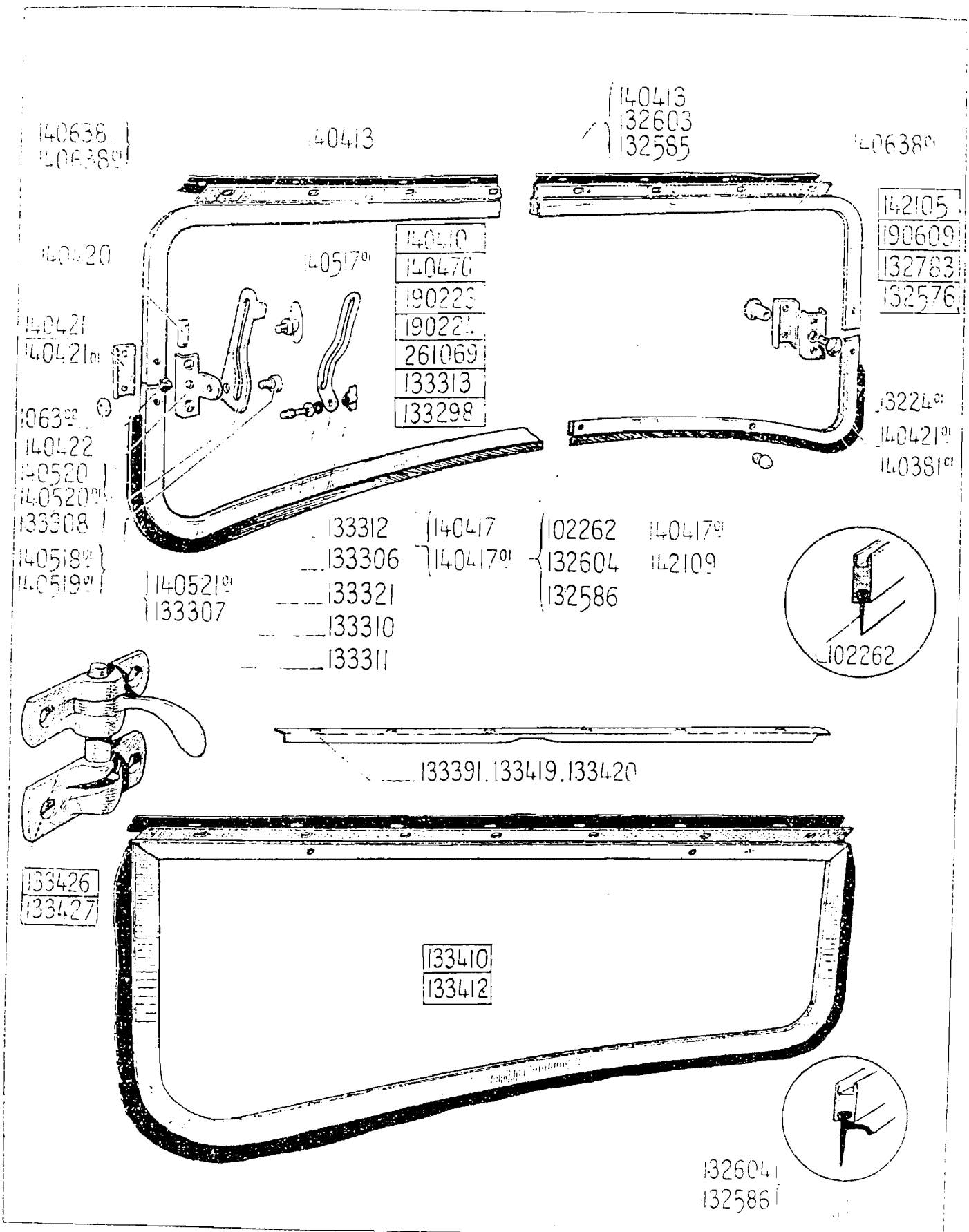



PARE-BRISE

PARE-BRISE TORPEDOS ET ROADSTERS EN 1 PIECE C4, C6, 8, 10, 15 CV

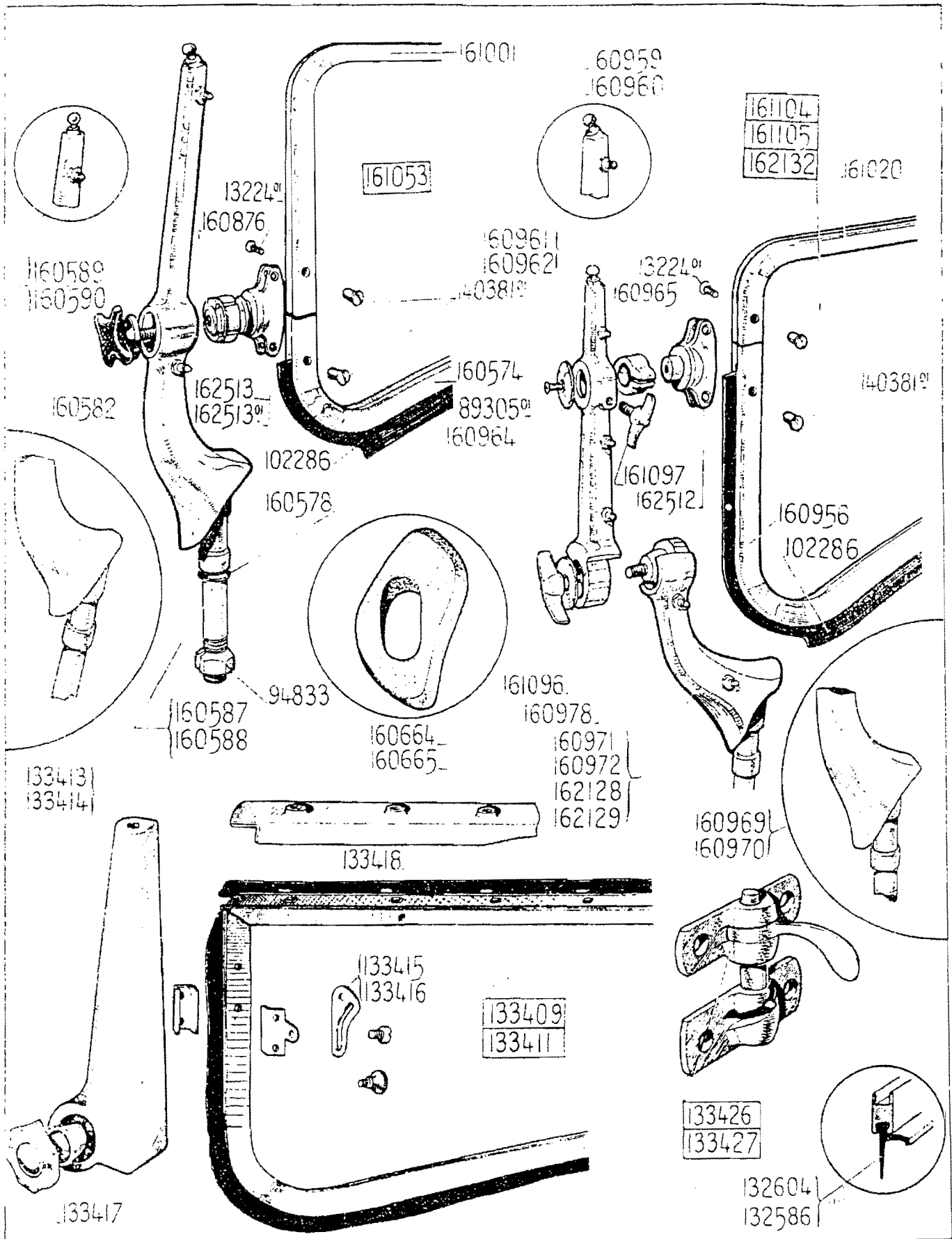

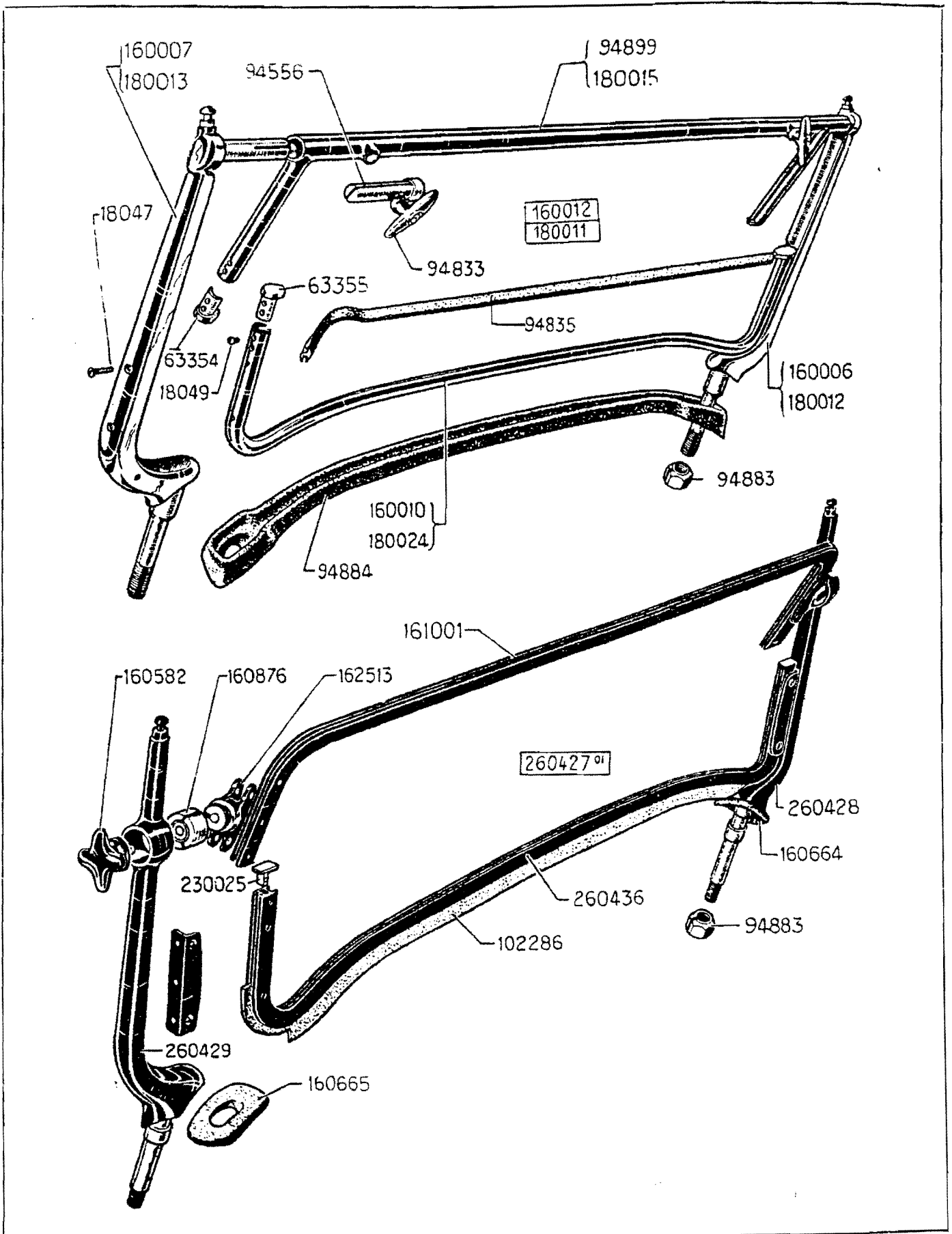

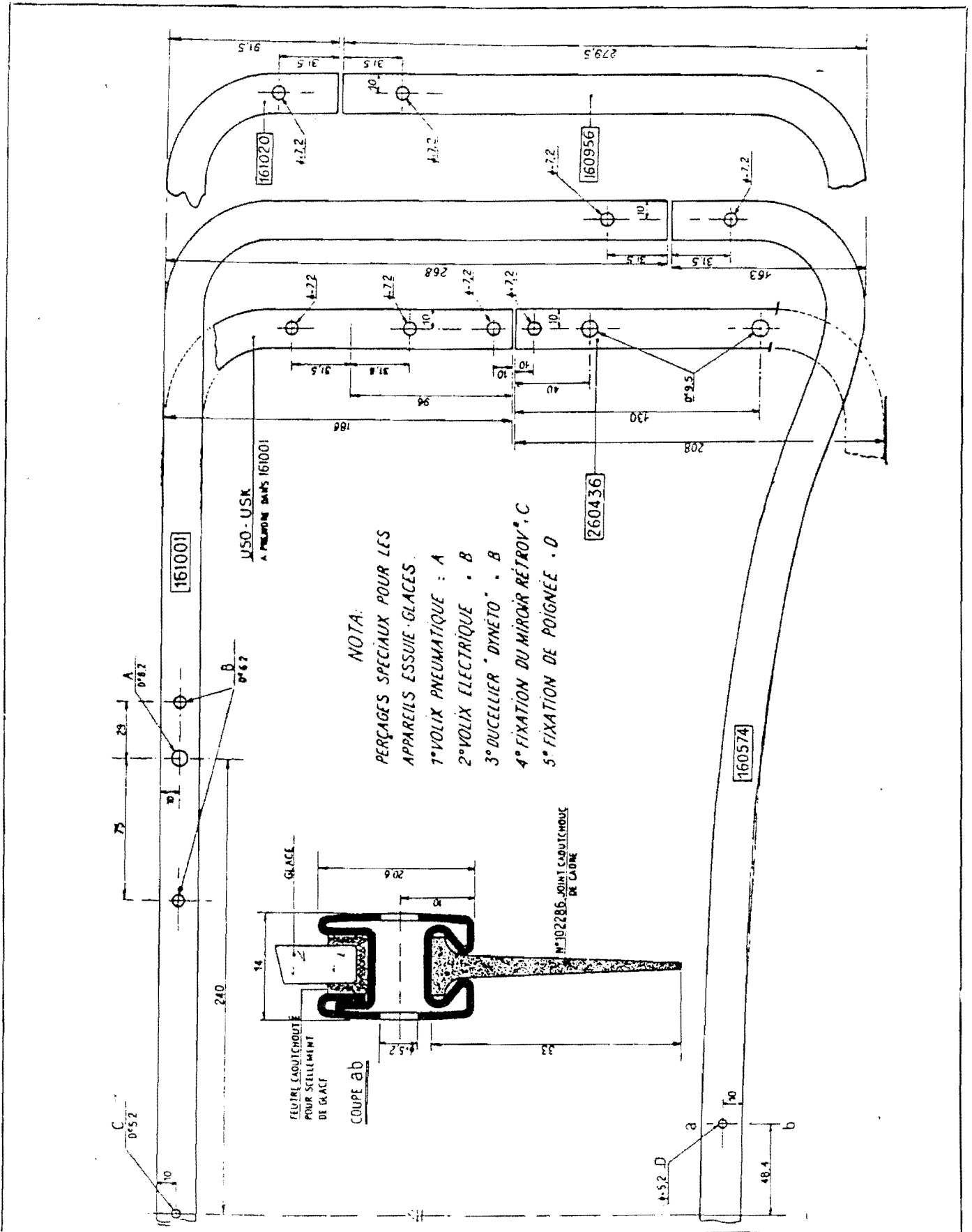



PORTIERES

PORTIERES POUR VOITURES FERMEES C4, C6

*Montage des serrures
1928 à 1930
partie à découper*

Left Side Part Numbers:
 142022, 635 Z
 130385, 765 Z
 150439

Right Side Part Numbers:
 142020, 635 Z
 130383, 230386, 765 Z
 231319, 220446
 261160

Bottom Left Part Numbers:
 142022, 142023
 130385, 130386
 150439, 150440

Bottom Right Part Numbers:
 130385, 405 Z
 130439, 540 Z

Top Right Part Numbers:
 142020, 142021
 130383, 130384
 230386, 230387
 231319, 231320
 220446, 220447
 261160, 261161

Dimensions:
 D (Door width)
 G (Curtain height)

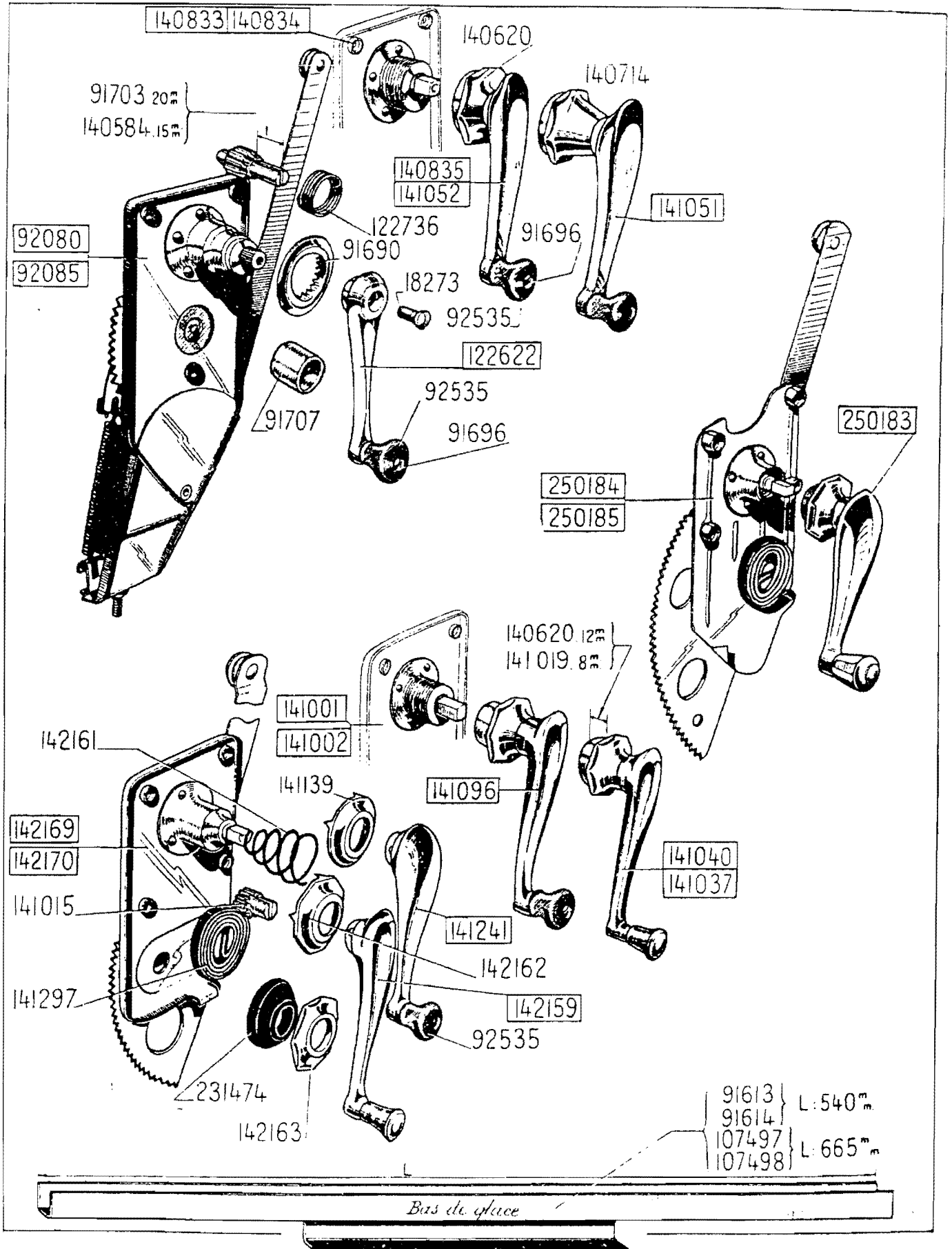

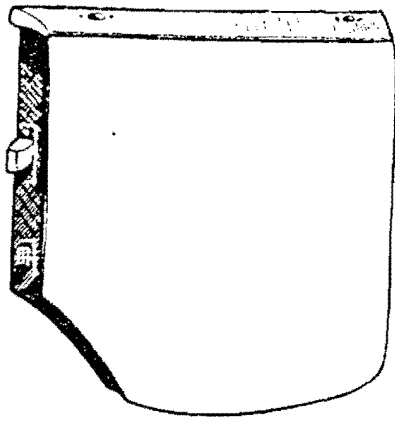

D 90799

G 90800

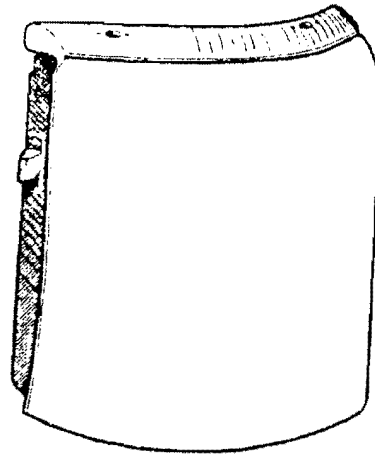

D 90658

G 90659

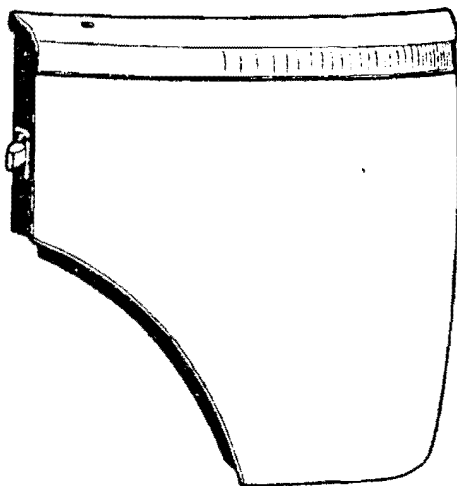

D 160862 G 160863

D 160864 G 160865

D 161080 G 161081

D 161082 G 161083

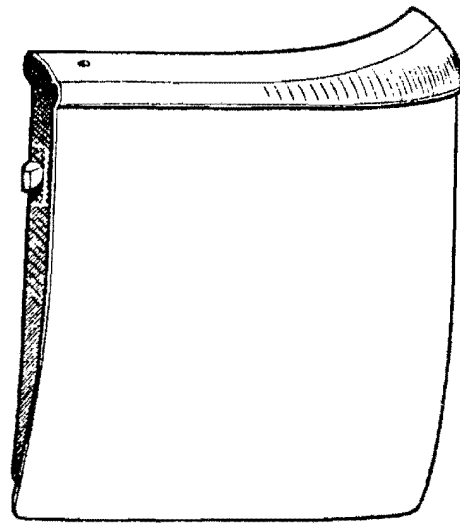

D 160860 G 160861

D 161084 G 161085

D 162207 G 162208

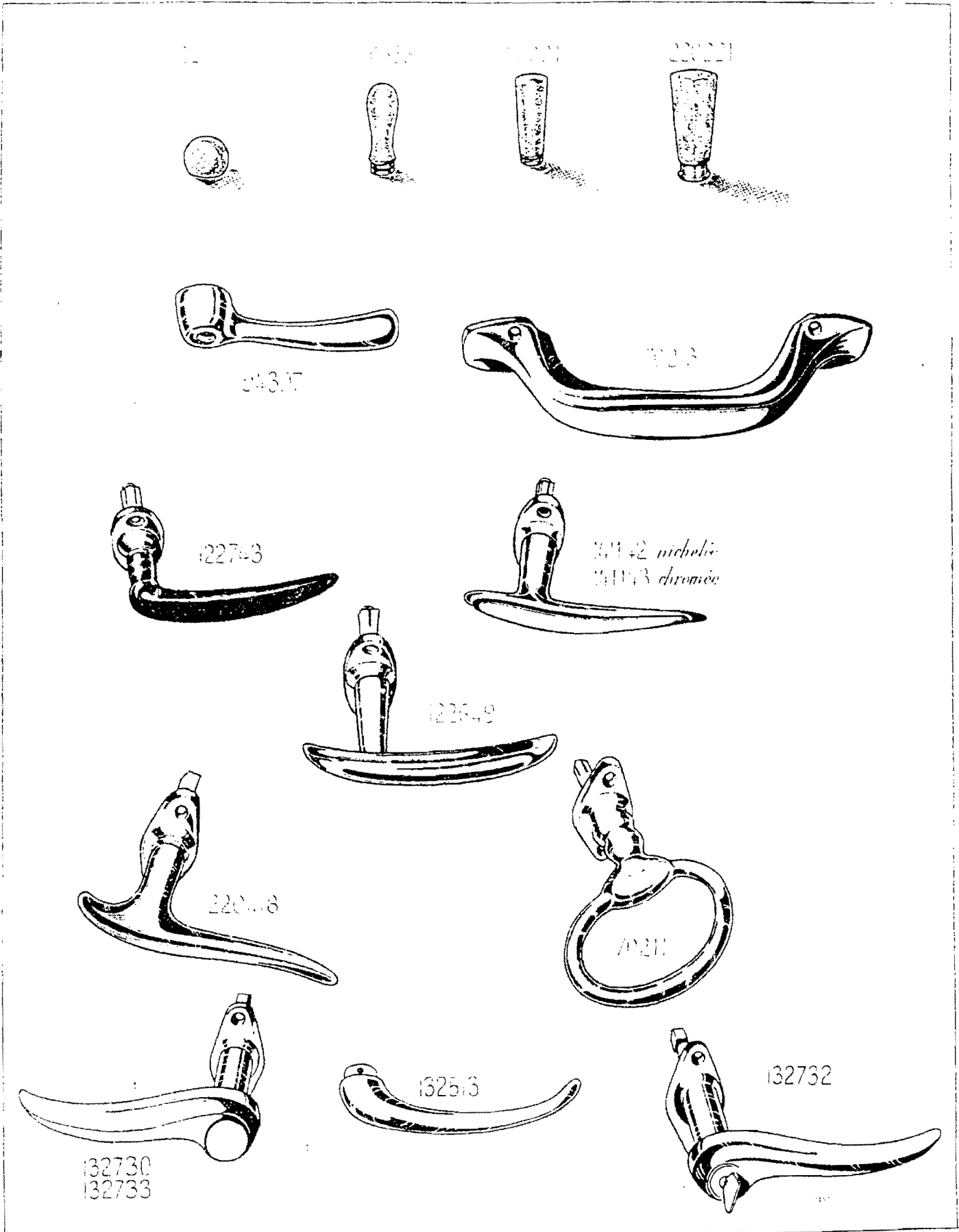

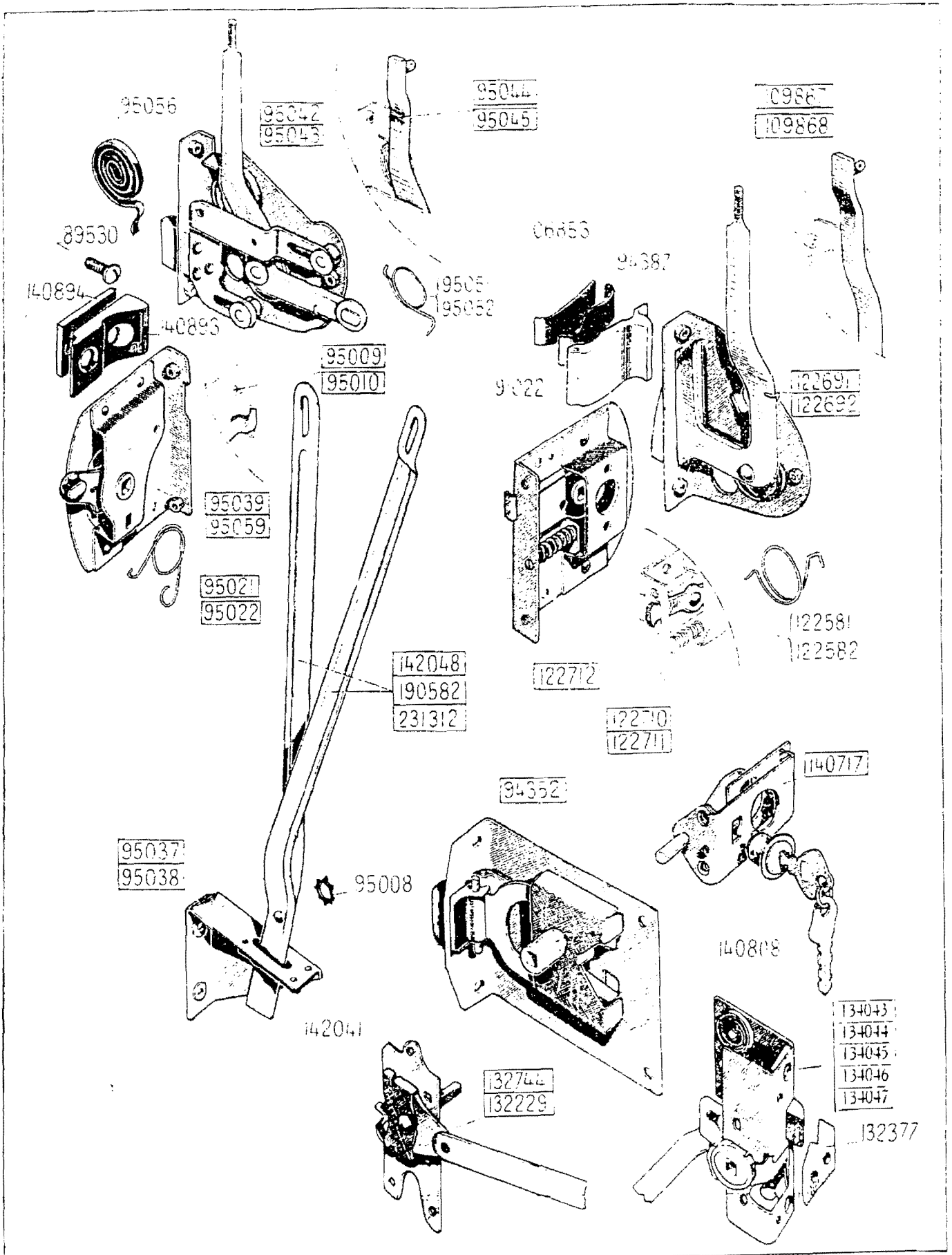



PORTIERES

BUTEES CAOUTCHOUC CALE-PORTE — PENE FIXE COULANTS DE GLACE

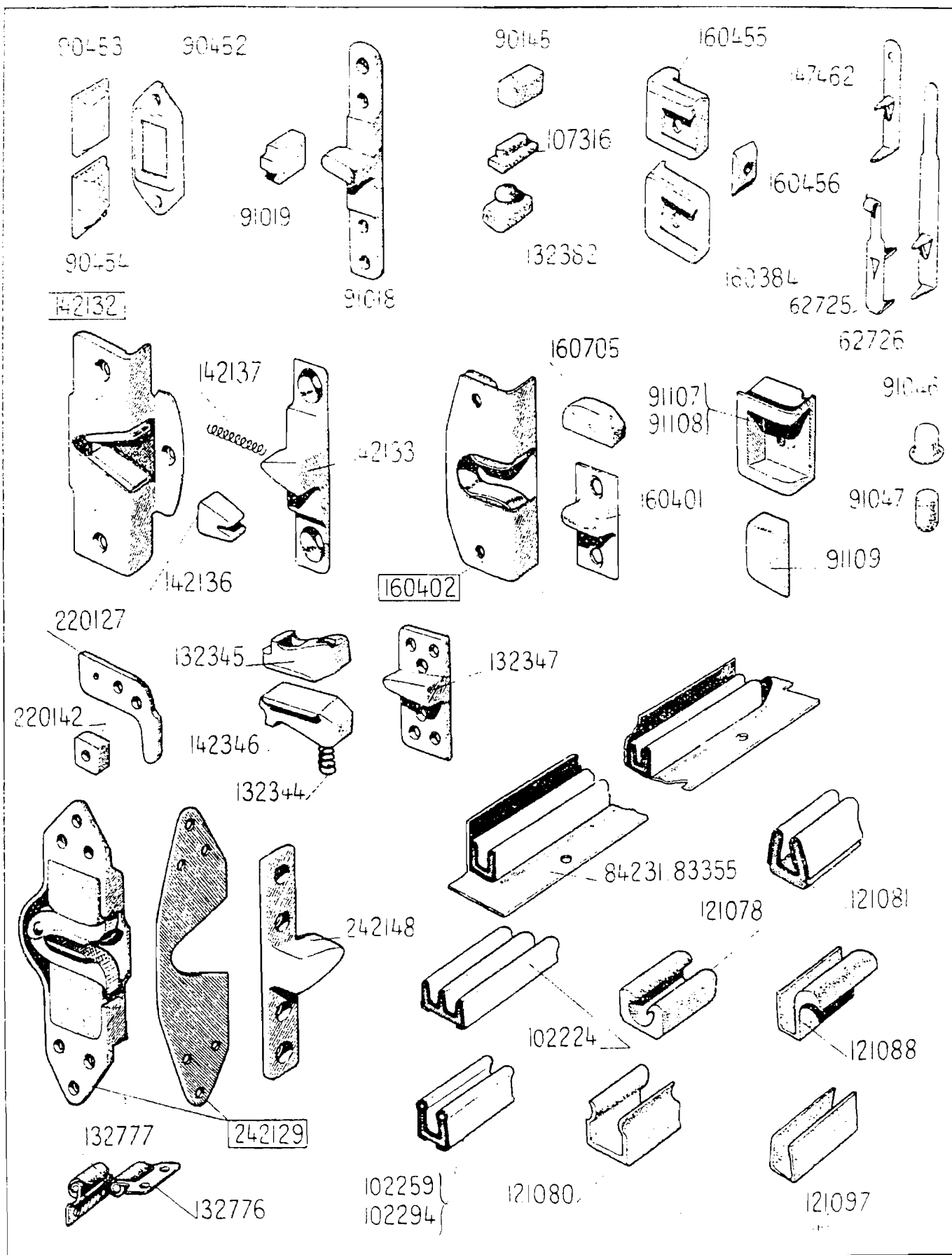

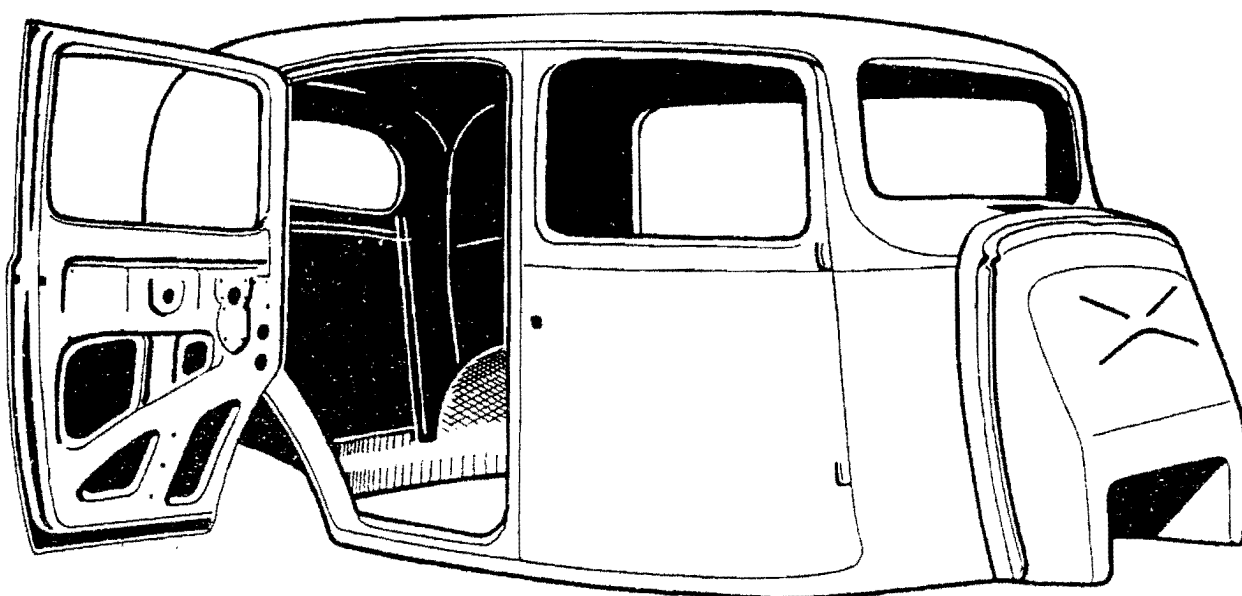
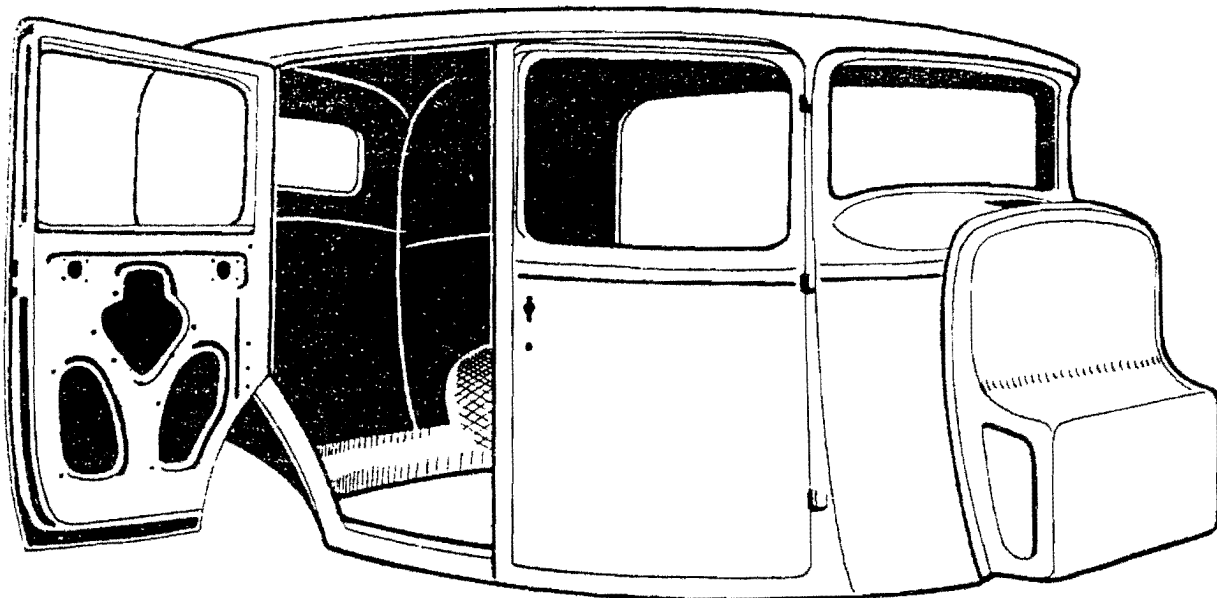

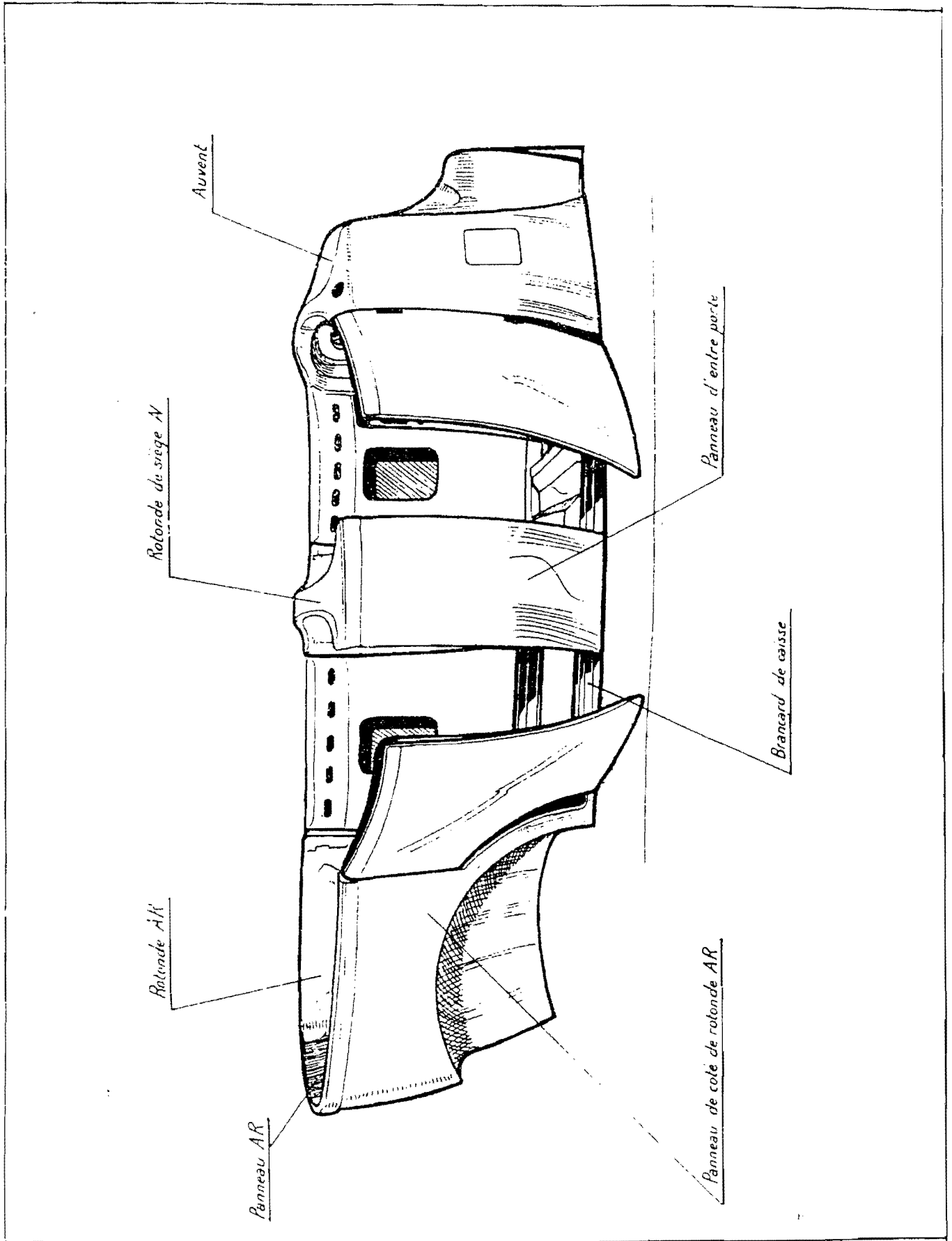

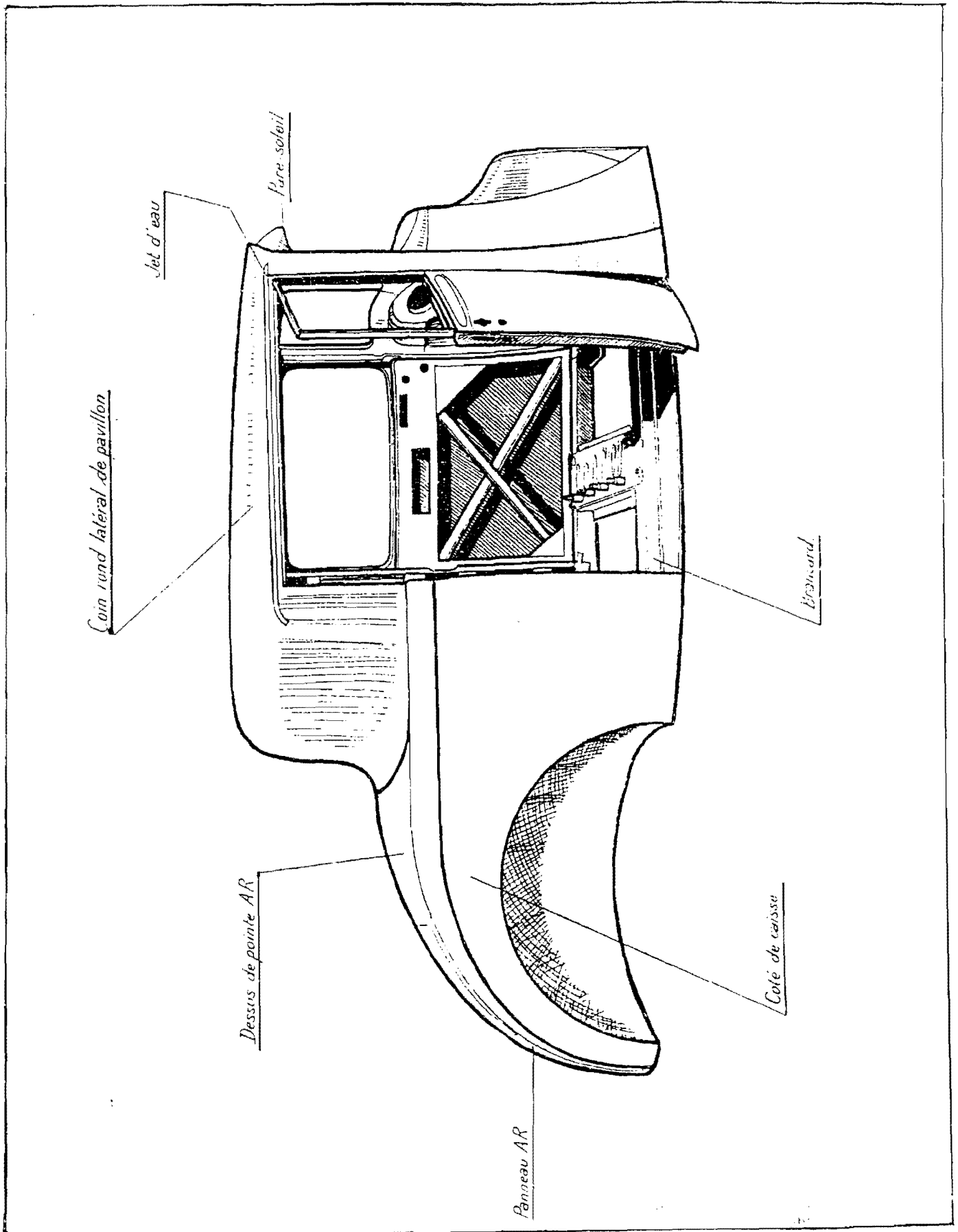

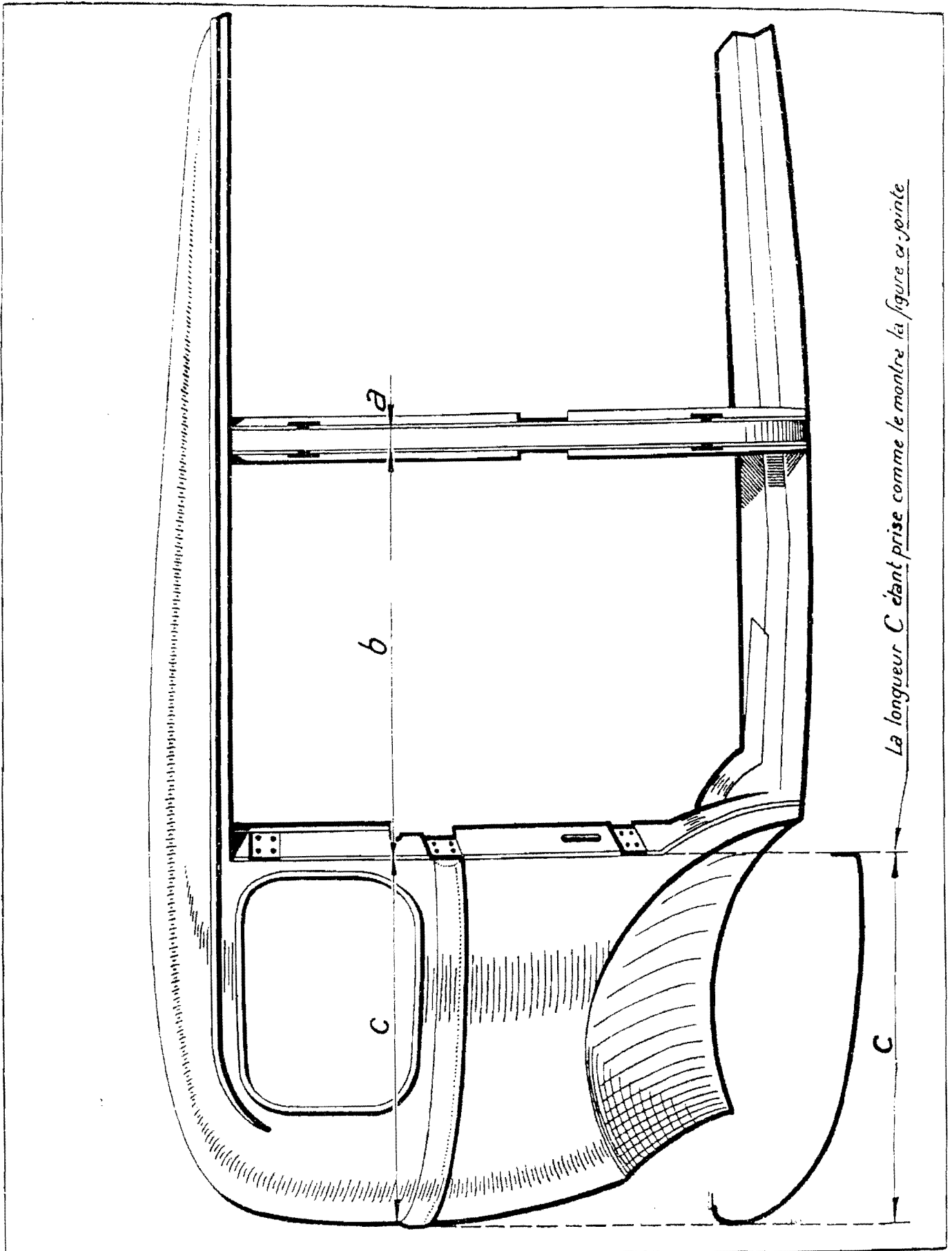

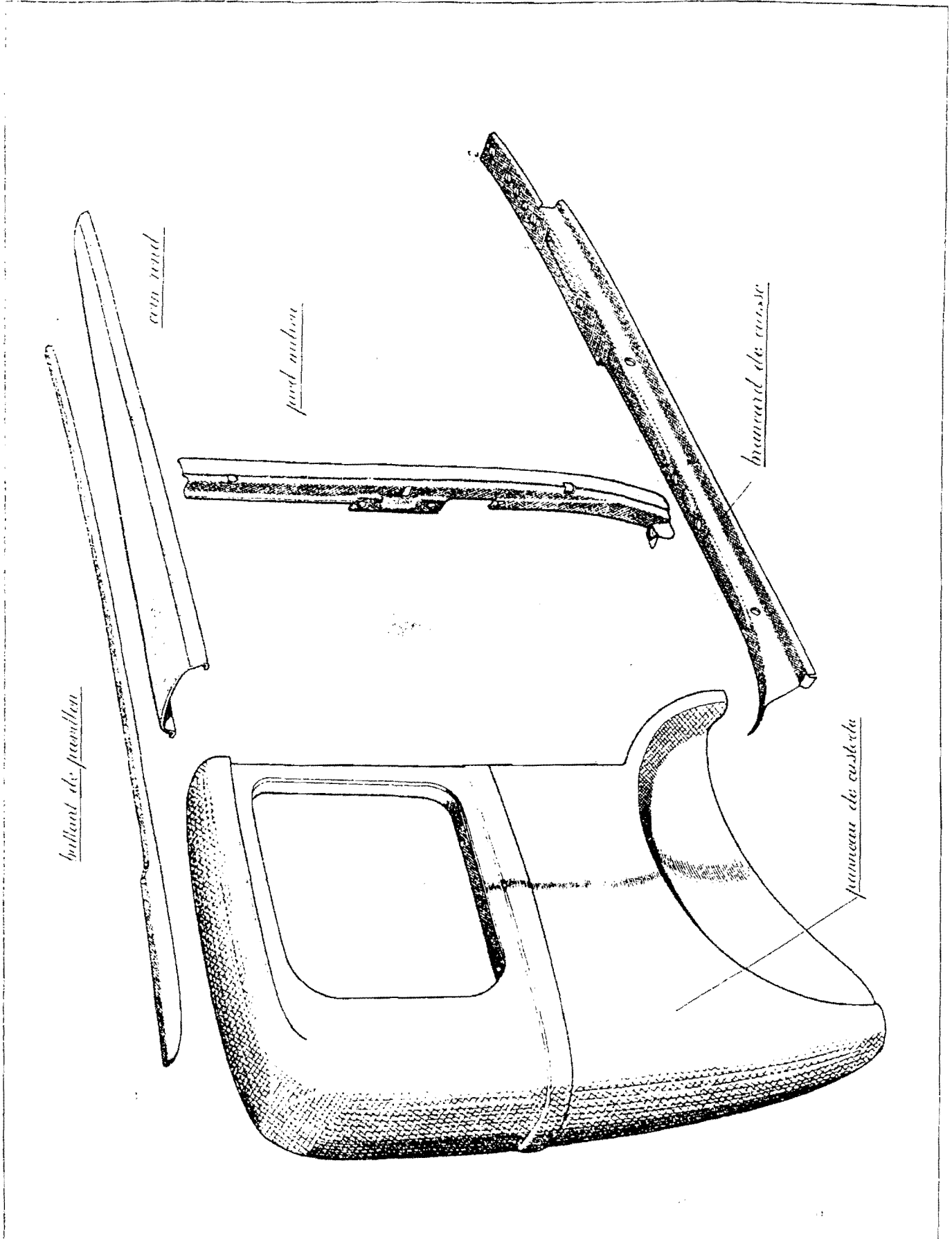

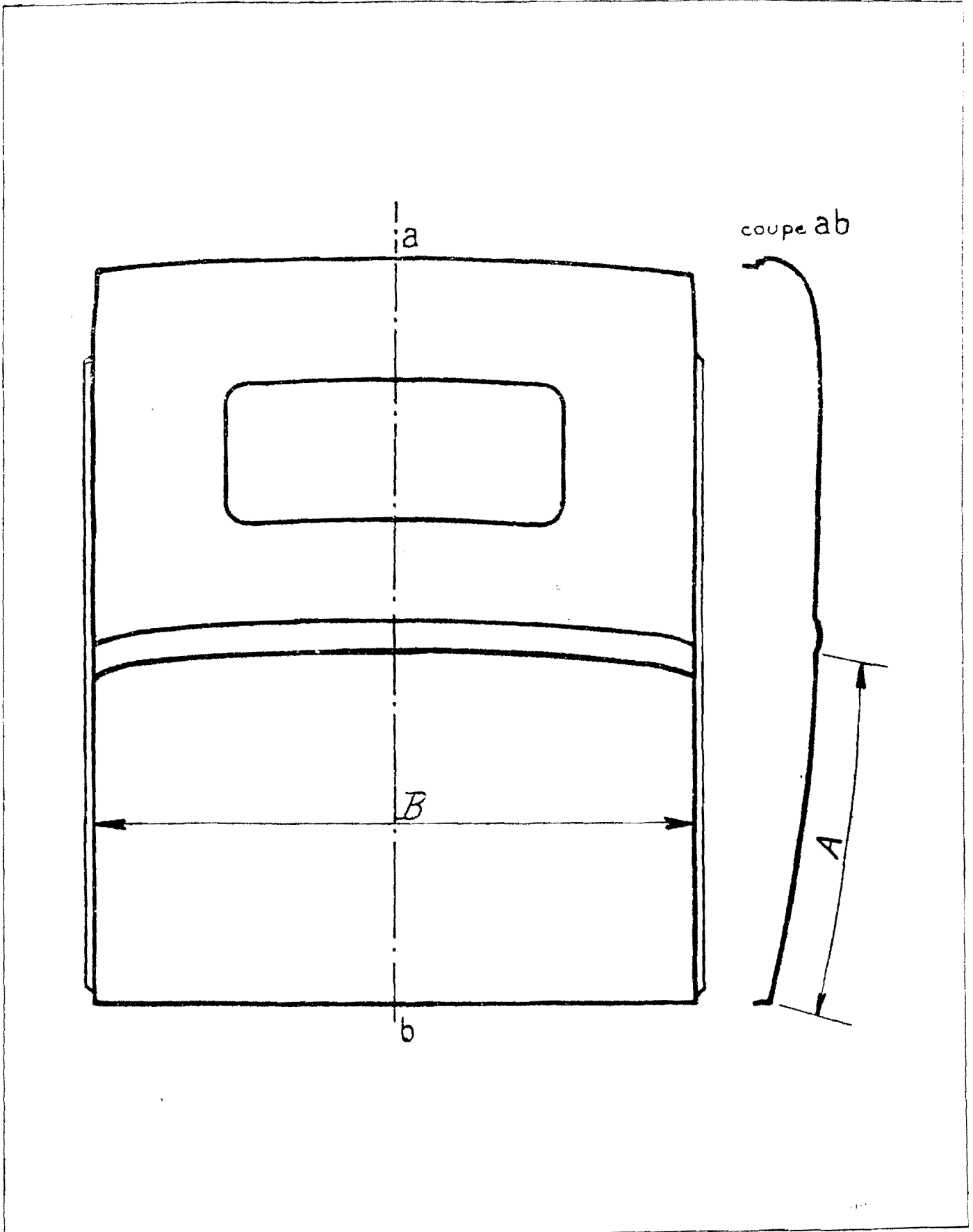

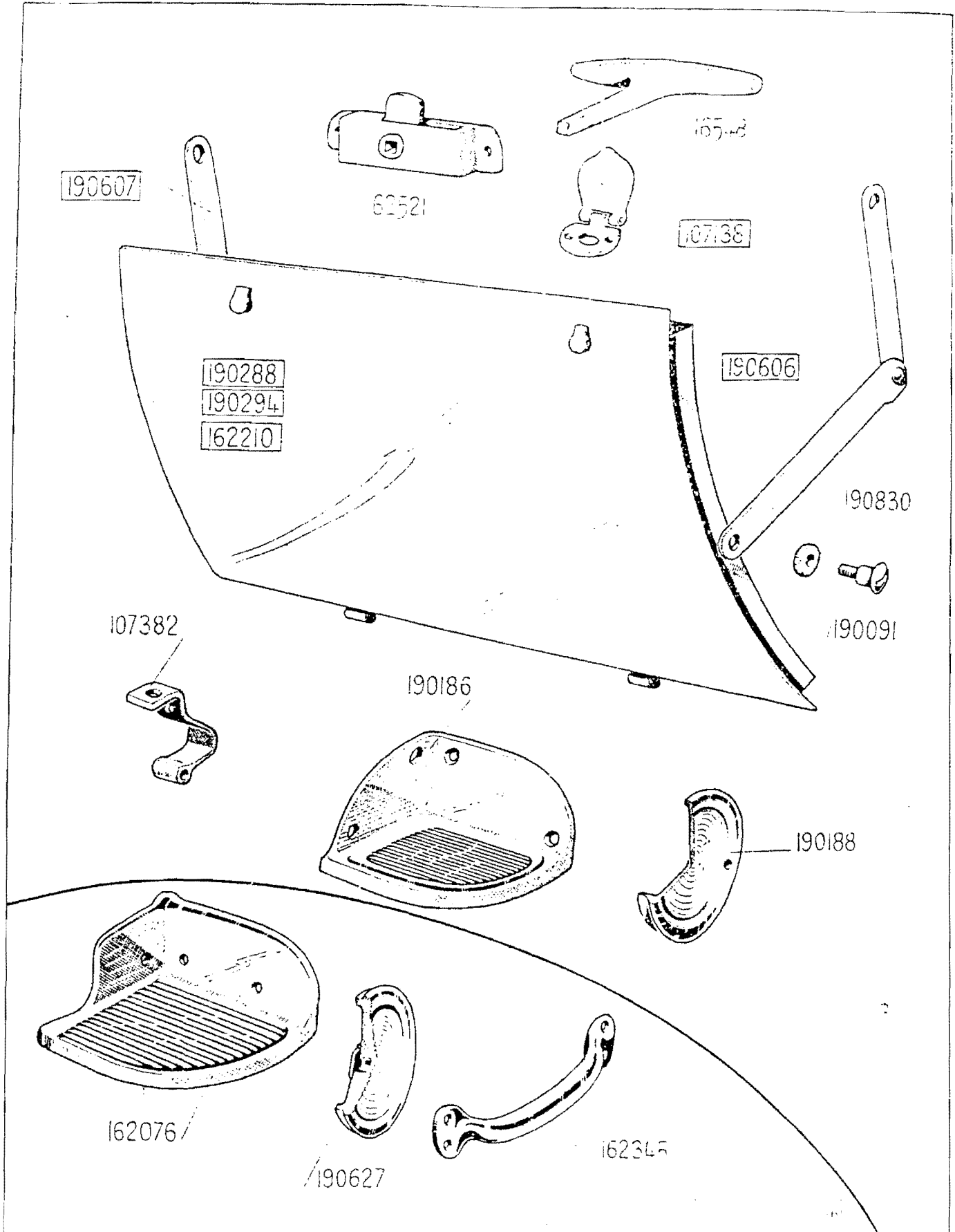

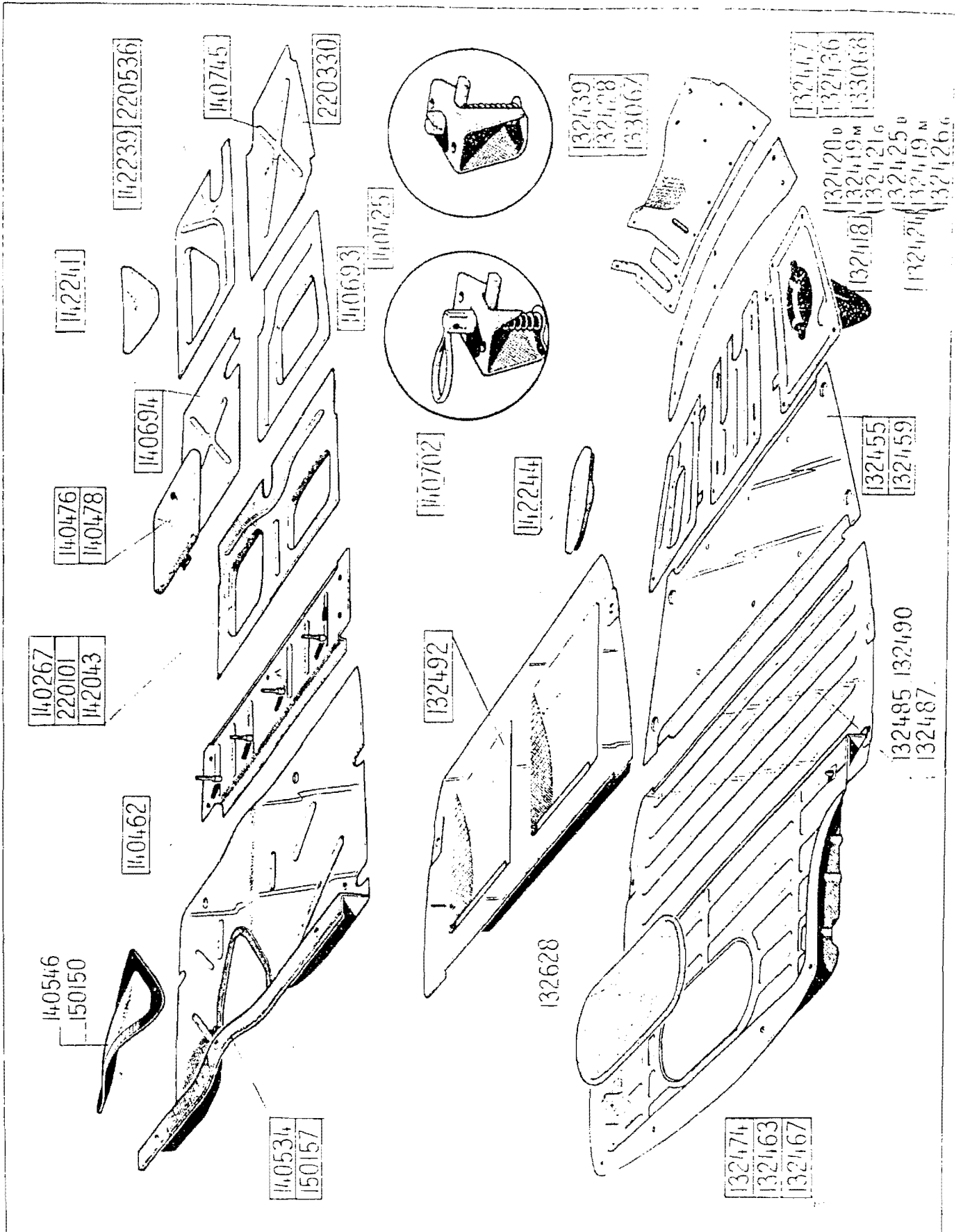

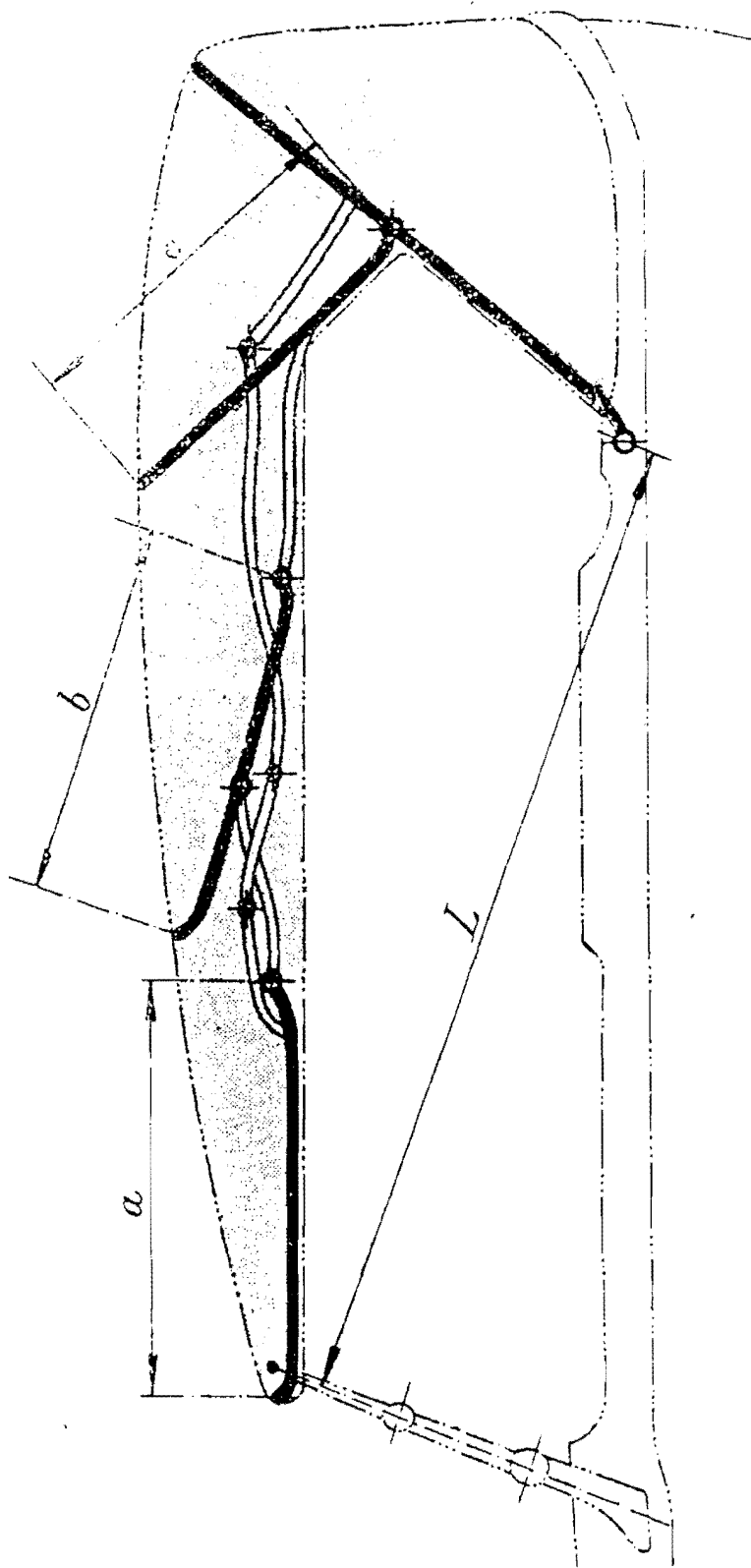

Symboles	L	a	b	c
SOP. CP.	1.57	931 ^{mm}	550 ^{mm}	470 ^{mm}
SO. SOT. SOV.	1.49	700	615	496
SOF. SOL.	1.73	853	682	625
SOA	1.88	853	682	625

L : entre axe du léton d'attache capote à l'axe d'artic.^{on}

a : longueur de l'arceau A'

b : intermédiaire A'

c : AR



PAVILLONS-CAPOTAGES

ACCESSOIRES DIVERS TORPEDOS. CABRIOLETS. TAXIS

